

KASTRUP

116778/708-196-1036

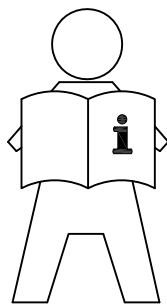



EN: IMPORTANT INFORMATION!

Please read the entire manual carefully before starting to assemble and/or using this product. Follow the manual thoroughly and keep it for further reference.

FR: INFORMATIONS IMPORTANTES

Veillez lire attentivement l'ensemble du manuel avant de commencer à monter et/ou utiliser ce produit. Suivez rigoureusement le manuel et conservez-le pour toute consultation ultérieure.

LV: SVARĪGA INFORMĀCIJA!

Pirms šī izstrādājuma montāžas un/vai lietošanas uzsākšanas pilnībā izlasiet lietošanas pamācību. Stingri ievērojiet pamācības norādījumus un saglabājiet to turpmākai lietošanai.

LT: SVARBI INFORMACIJA!

Prieš pradėdami montuoti gaminį ir (arba) juo naudotis, prašome atidžiai perskaityti visą vadovą. Atidžiai skaitykite vadovą ir turėkite jį su savimi, kad galėtumėte toliau vadovautis jo nuorodomis.

EE: OLULINE TEAVE!

Enne kui alustate toote kokku panemist ja/või kasutamist, lugege see kasutusjuhend hoolikalt läbi. Järgige täpselt juhendis toodud juhiseid ja hoidke juhend alles.

BY: ВАЖНАЯ ИНФОРМАЦИЯ!

Внимательно и полностью прочитайте это руководство, прежде чем приступать к сборке или использованию этого изделия. Следуйте всем инструкциям этого руководства и сохраните его на будущее для справки.

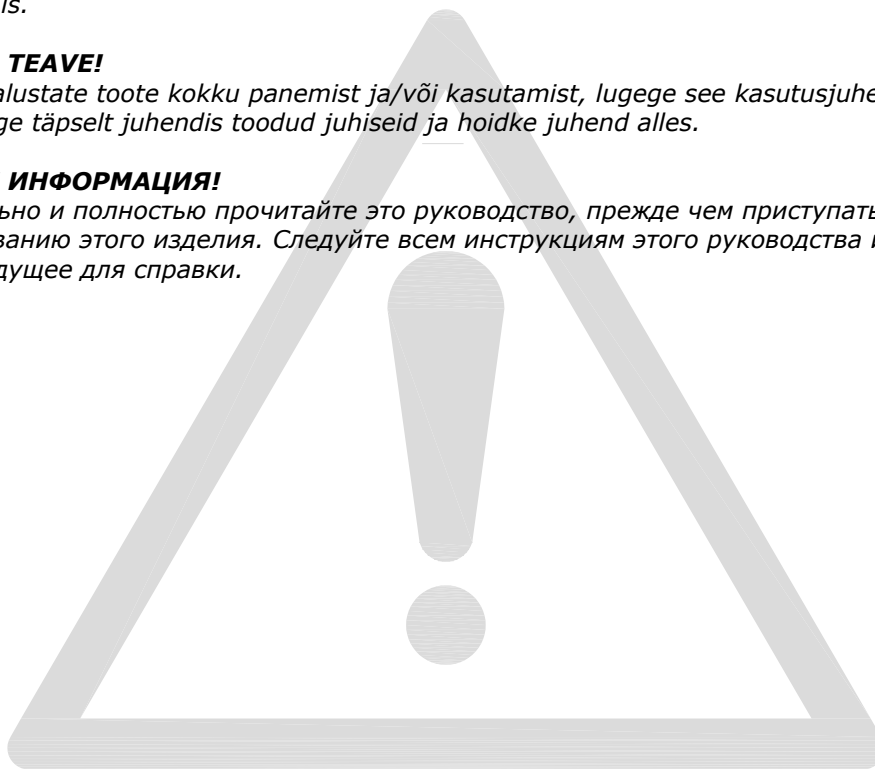

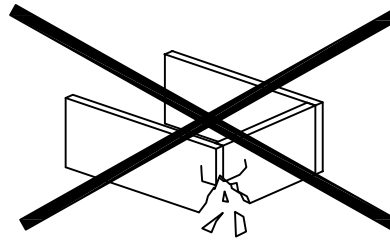
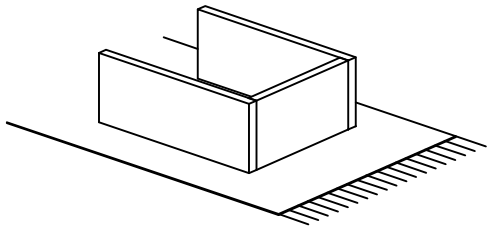

EN: WARNING TO AVOID SCRATCHES!

In order to avoid scratching this furniture should be assembled on a soft layer - could be a rug.

FR: AVERTISSEMENT POUR ÉVITER LES RAYURES

Afin d'éviter les rayures, ce meuble doit être monté sur une surface souple (un tapis, par exemple).

LV: BRĪDINĀJUMS PAR SKRĀPĒJUMIEM!

Lai nesaskrāpētu šo izstrādājumu, veiciet montāžu uz mīkstas pamatnes, piemēram, paklāja.

LT: ĮSPĖJIMAS, KAD IŠVENGTUMĖTE ĮBRĖŽIMŲ!

Šio baldo nesubraižysite, jei jį surinksite ant švelnaus paviršiaus, pavyzdžiui, kilimo.

EE: HOIATUS KRIIMUSTUSTE VÄLTIMISEKS!

Kriimustuste tekkimise vältimiseks mööblile tuleb see kokku panna pehmel pinnal, nt kaltsuvaibal.

BY: ПРЕДУПРЕЖДЕНИЕ ОТНОСИТЕЛЬНО ЦАРАПИН!

Во избежание нанесения царапин, сборку этой мебели необходимо выполнять на мягкой поверхности, например на ковре.



EN: IMPORTANT!

It is important that any product which is assembled using any kind of screw is re-tightened 2 weeks after assembly, and once every 3 months - in order to assure stability through-out the lifespan of the product.

FR: IMPORTANT

Il est important que tout produit monté à l'aide de vis soit resserré 2 semaines après son montage, puis tous les 3 mois, afin de garantir sa stabilité durant tout son cycle de vie.

LV: SVARĪGI!

Ir svarīgi, lai jebkuram produktam, kas tiek uzstādīts ar jebkādu skrūvju palīdzību, skrūves tiktu atkārtoti pievilktas 2 nedēļas pēc montāžas; pēc tam – reizi 3 mēnešos, tā nodrošinot stabilitāti visā izstrādājuma kalpošanas laikā.

LT: SVARBU!

Bet kokį varžtais tvirtinamą gaminį 2 savaites po surinkimo bei kas 3 mėnesius reikia papildomai suveržti – taip užtikrinamas naudojamo gaminio stabilumas.

EE: TÄHTIS!

Oluline on, et toote kruvisid pingutataks 2 nädalat pärast kokkupanekut ja seejärel iga 3 kuu järel, et tagada stabiilsus kogu toote eluea jooksul.

BY: ВАЖНО!

В любом изделии, собранном с использованием винтов любого типа, необходимо через 2 недели после сборки и в дальнейшем каждые 3 месяца подтягивать винты, чтобы обеспечить прочность изделия в течение срока эксплуатации.



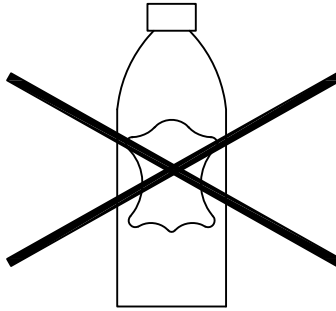

EN: MATERIALS MADE OF PU/BONDED LEATHER!

Products covered in PU/Bonded leather, must not be treated with leather care products, since they will destroy the PU/ Bonded leather.

FR: MATÉRIAUX COMPOSÉS DE PU/CUIR RECONSTITUÉ

Les produits recouverts de PU/cuir reconstitué ne doivent pas être traités à l'aide de produits d'entretien du cuir, car ces derniers endommageraient le PU/cuir reconstitué.

LV: MATERIĀLI NO PU/ PĀRSTRĀDĀTAS ĀDAS!

Izstrādājumiem ar PU/pārstrādātas ādas pārklājumu nedrīkst izmanto ādas kopšanas līdzekļus, jo tie sabojās PU/pārstrādāto ādu.

LT: MEDŽIAGOS PAGAMINTOS IŠ PU /PERDIRBTOS ODOS!

PU arba perdirbta oda aptrauktų gaminių nevalykite odos priežiūros priemonėmis, nes, tikėtina, kad jos sugadins PU arba perdirbtą odą.

EE: PU-st/KOKKUPRESSITUD NAHAST VALMISTATUD MATERJALID!

PU-ga/kokkupressitud nahaga kaetud tooteid ei tohi töödelda nahahooldustoodetega, sest viimased kahjustavad PU-d/kokkupressitud nahka.

BY: МАТЕРИАЛЫ ИЗ ПОЛИУРЕТАНА / ИСКУССТВЕННОЙ КОЖИ!

Изделия с покрытием из полиуретана или искусственной кожи нельзя чистить средствами для ухода за натуральной кожей, они испортят покрытие.

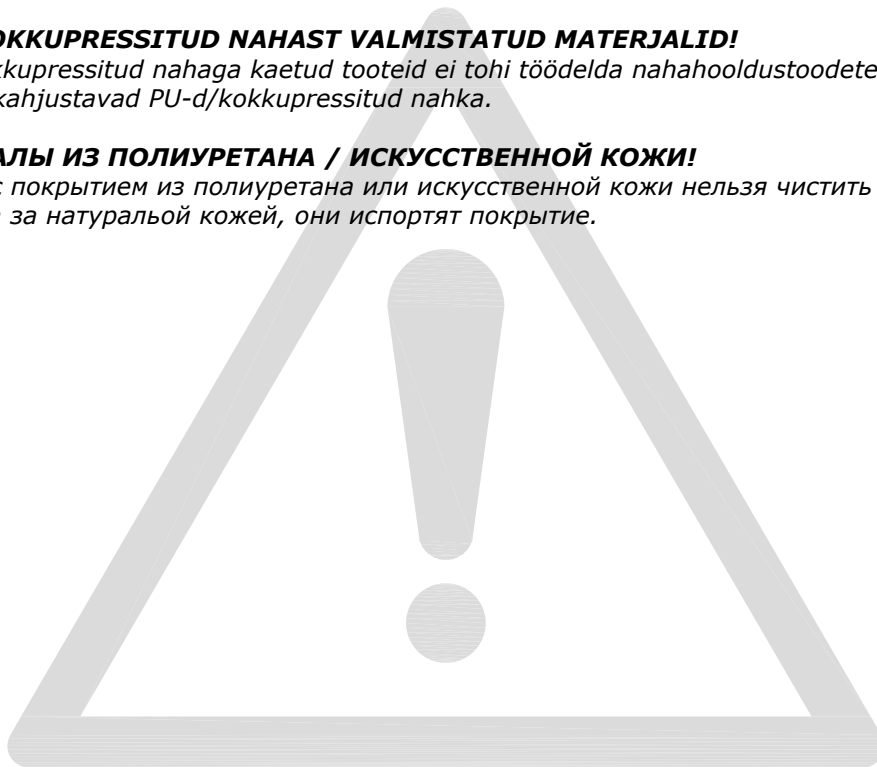

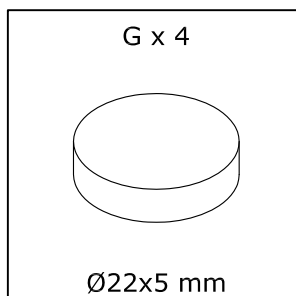
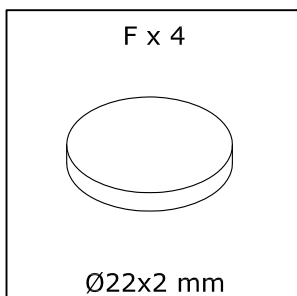
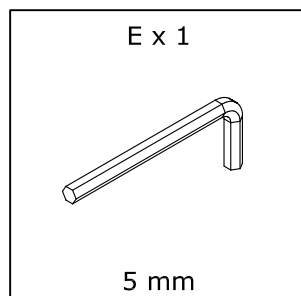
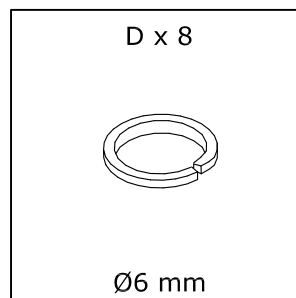
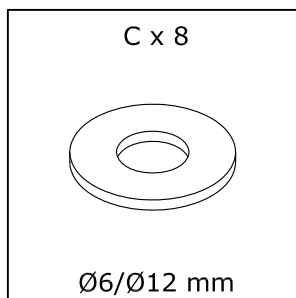
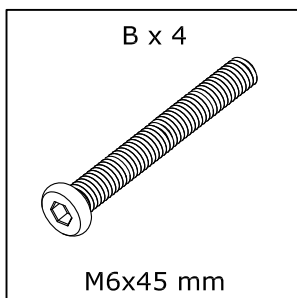
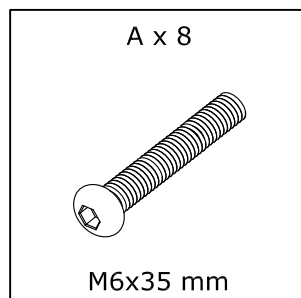
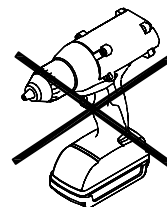

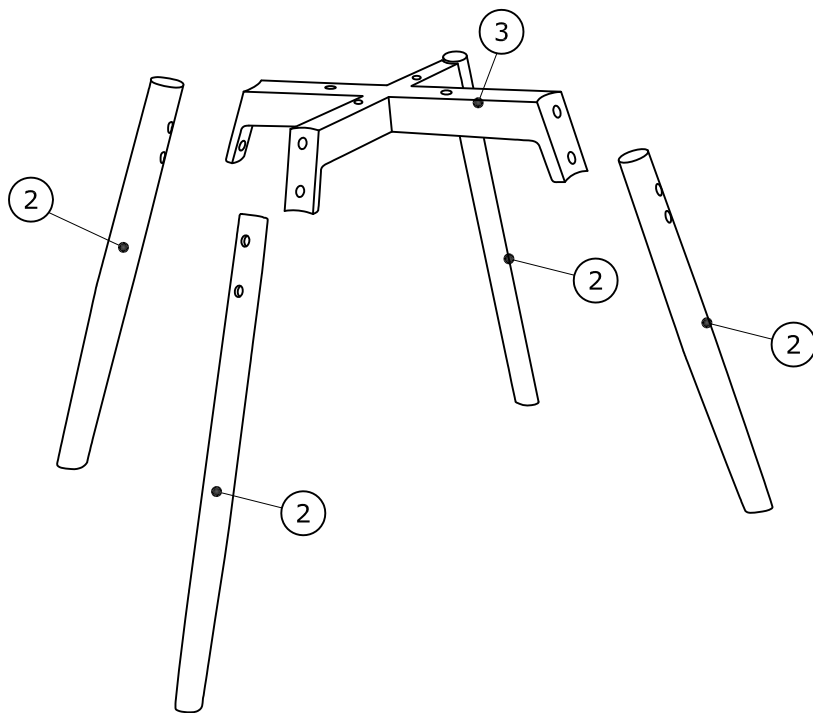
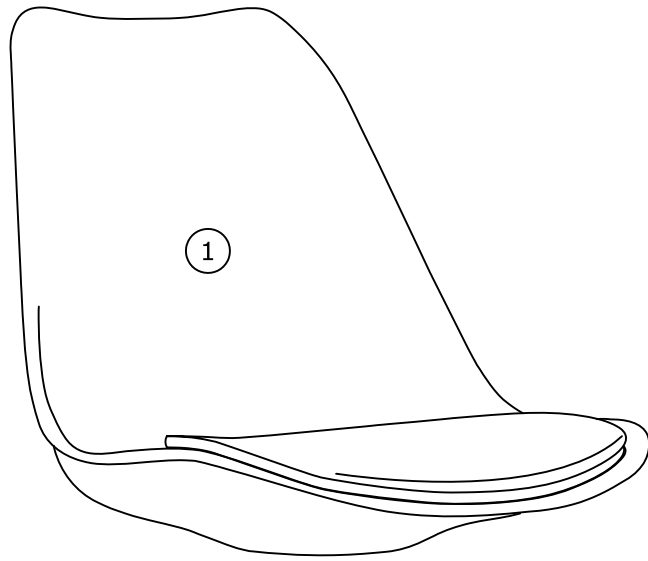

Box 1/1:

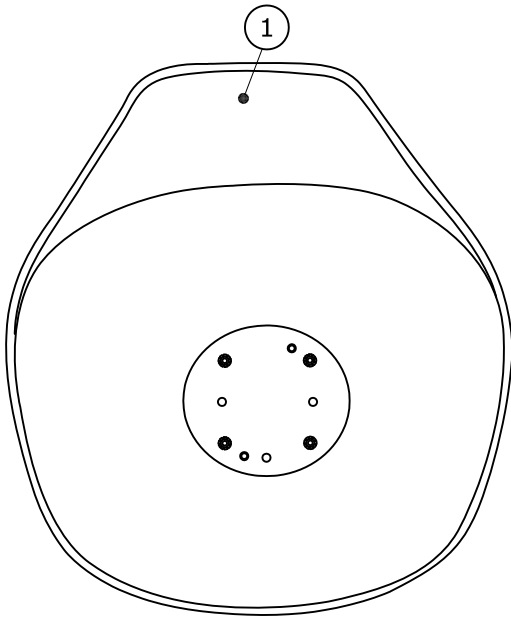

460x485x550 mm

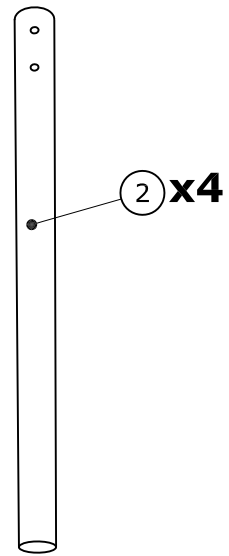

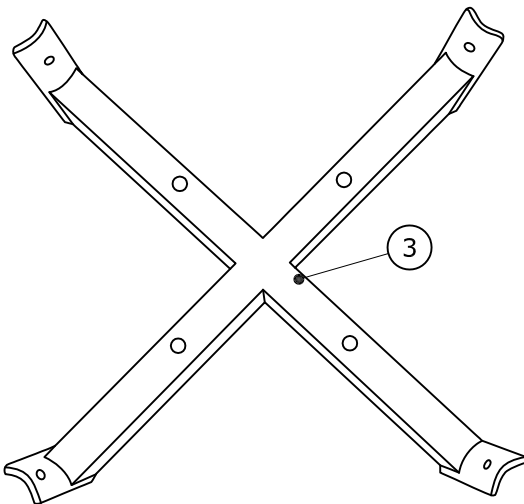

Ø30x428 mm

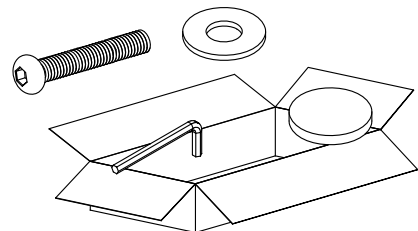

330x330x65 mm

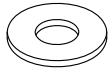

1

A x 8  M6x35 mm	C x 8  Ø6/Ø12 mm	D x 8  Ø6 mm	E x 1  5 mm	
--	---	---	--	--

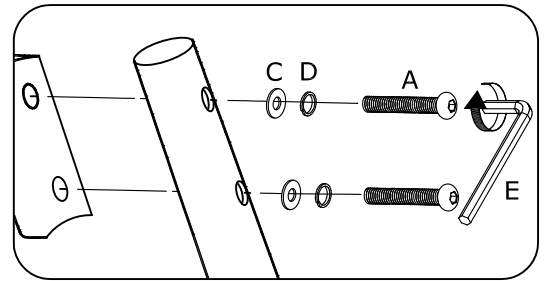
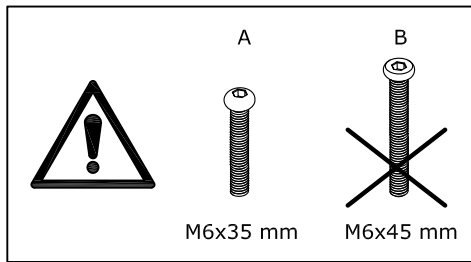
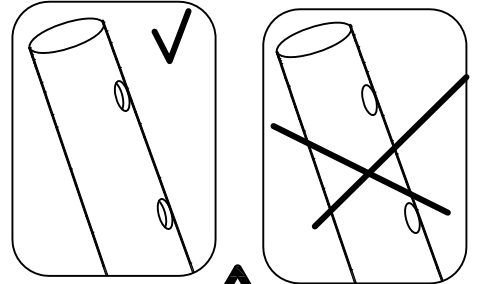
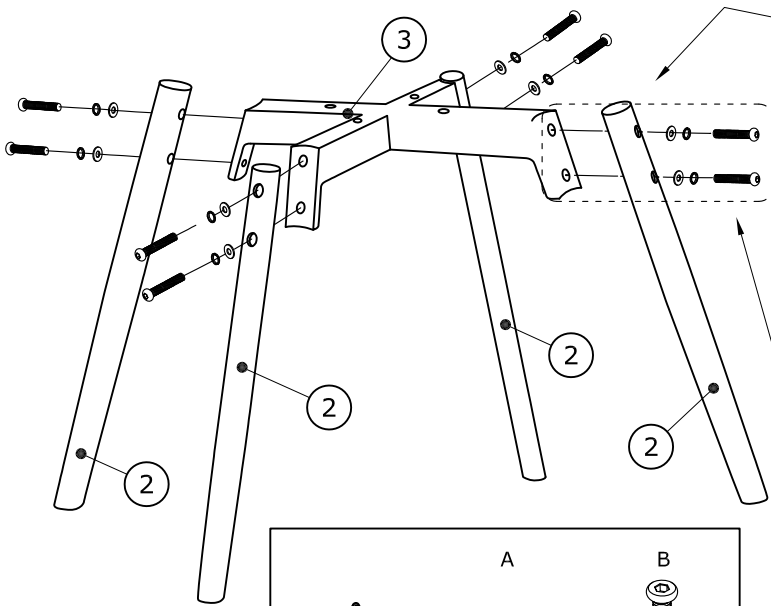

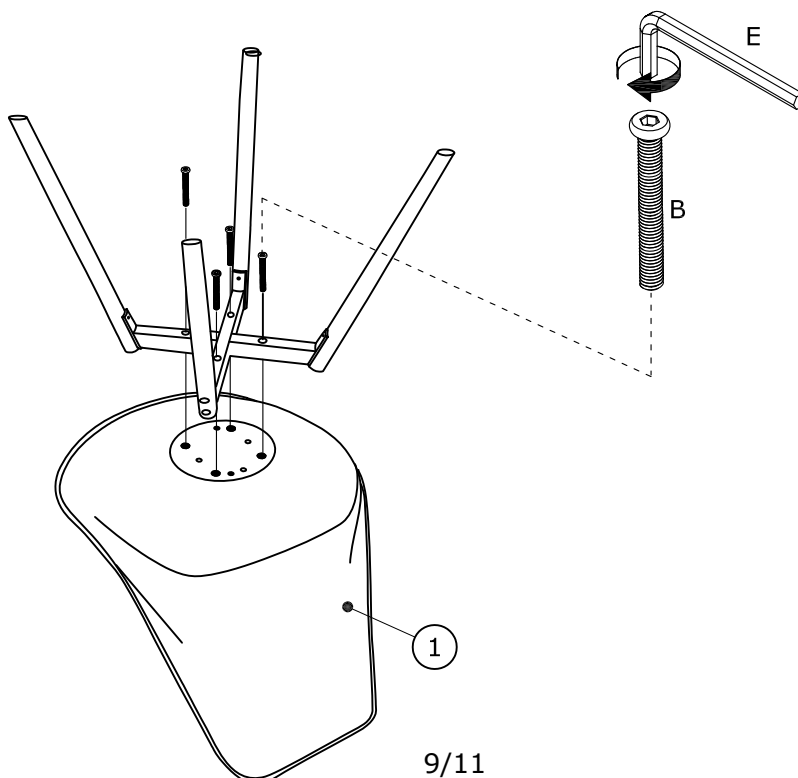

2

B x 4  M6x45 mm	E x 1  5 mm	
--	--	--

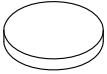

3

F x 4  Ø22x2 mm	G x 4  Ø22x5 mm	
--	--	--

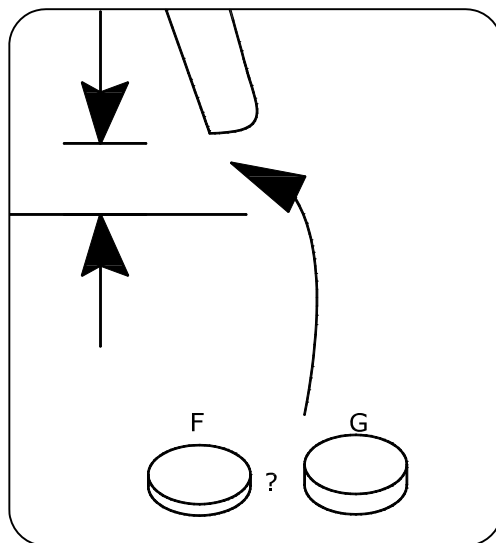
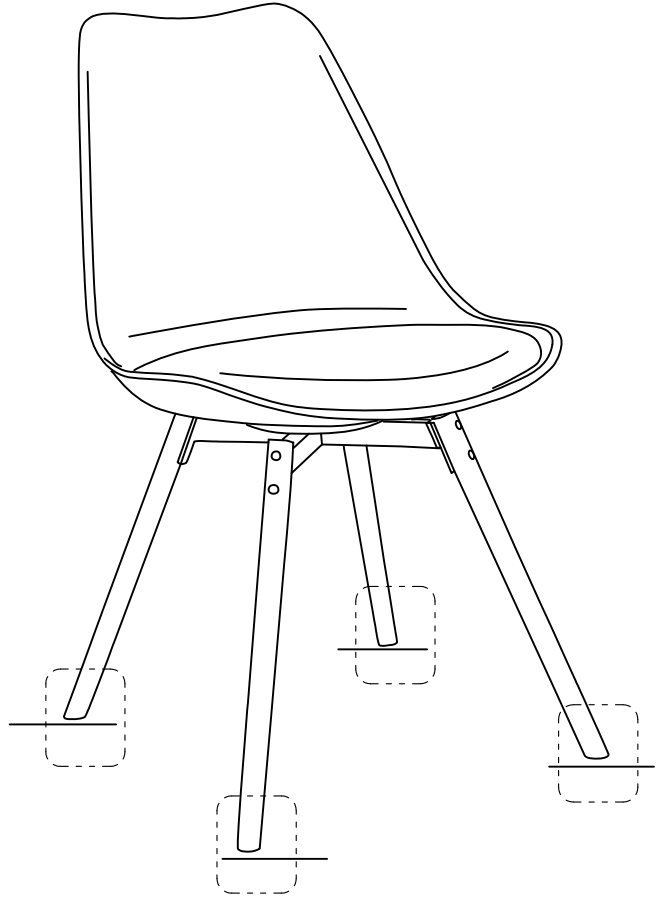

4



GAMMELGAB

117132/
709-216-1012

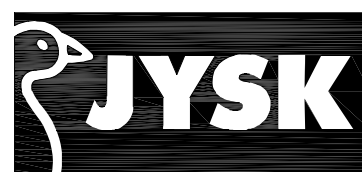
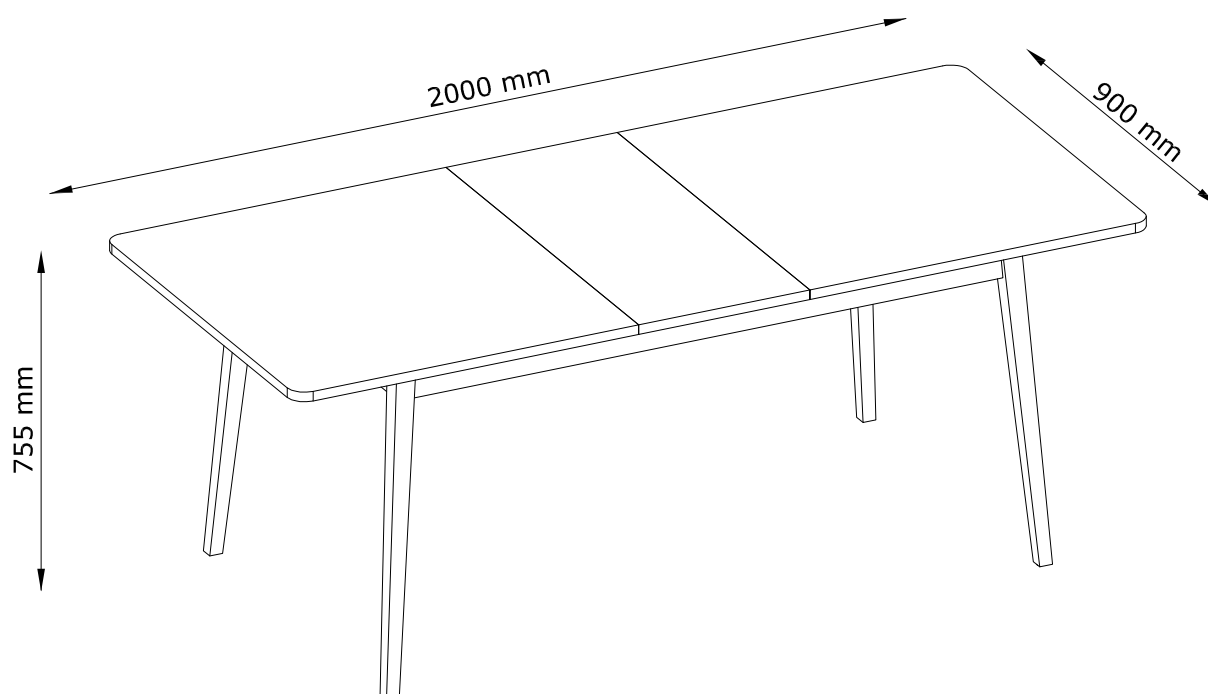
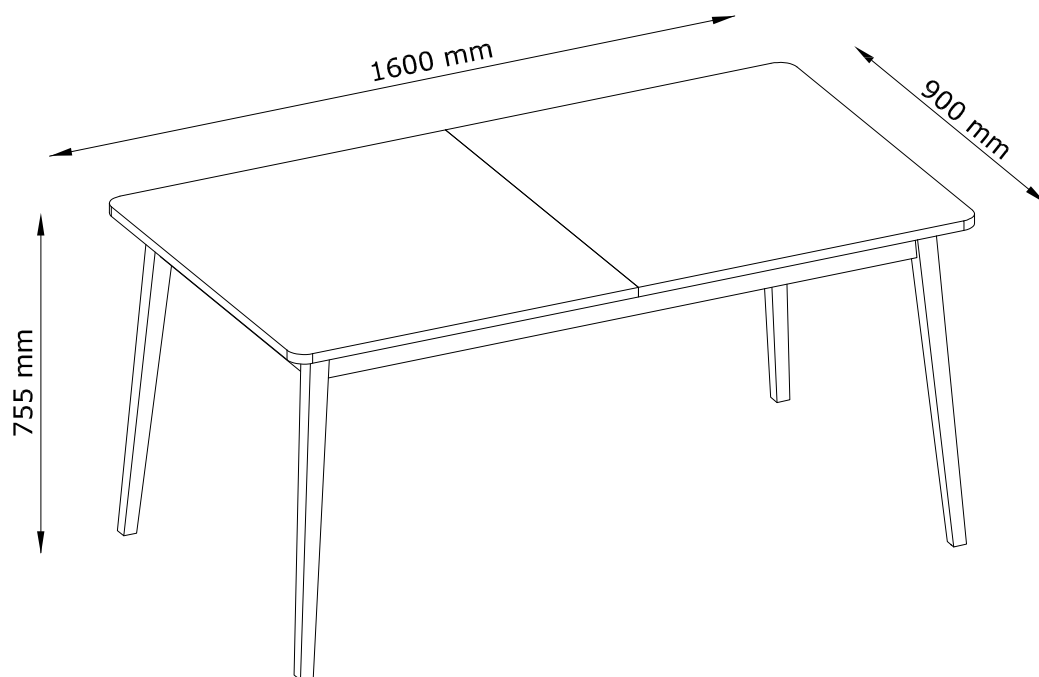

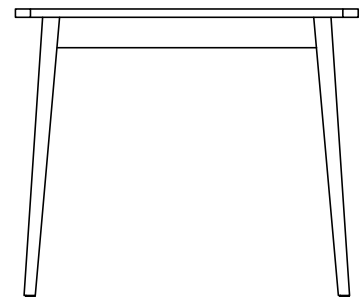
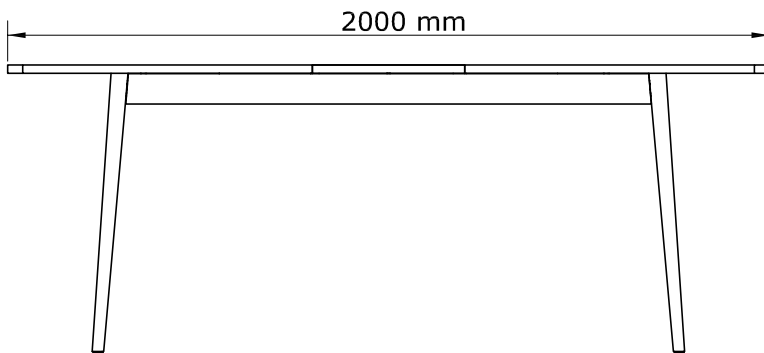
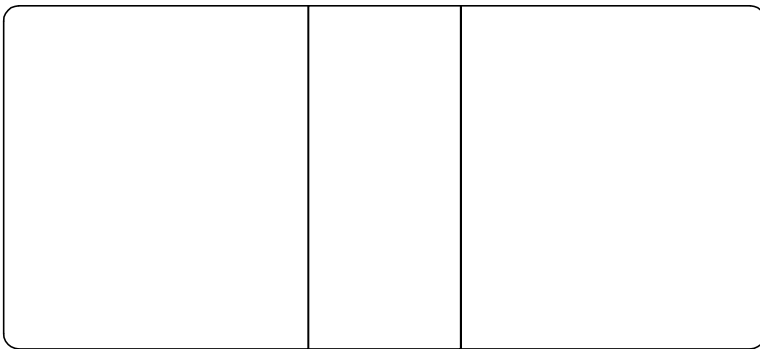
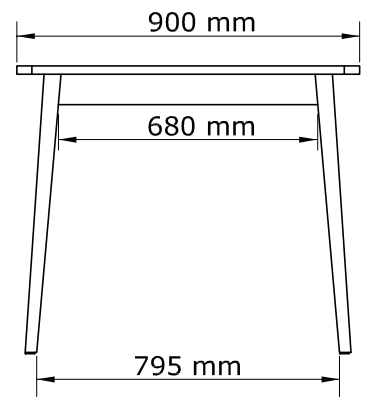
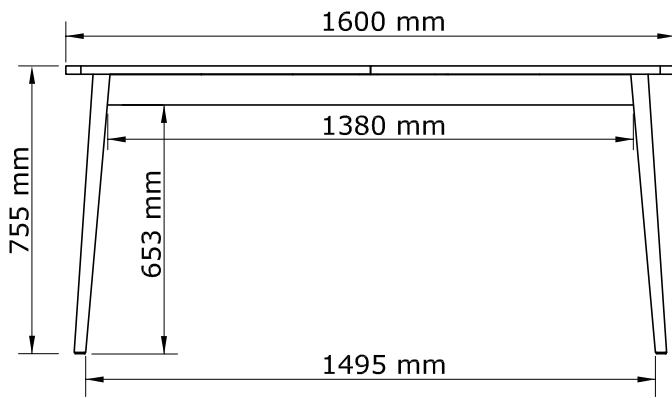
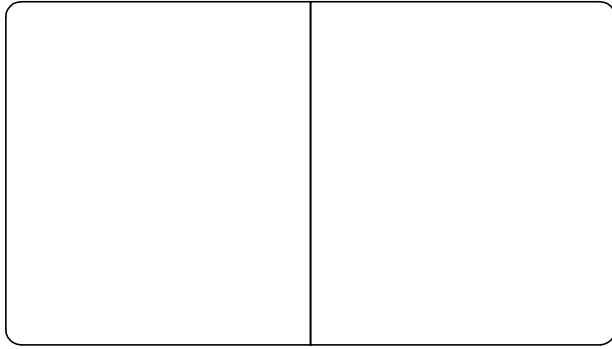

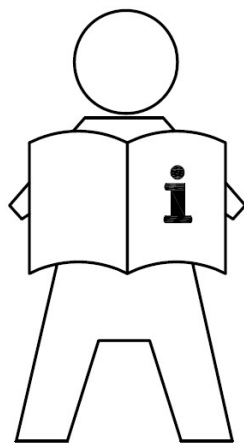

EN: IMPORTANT INFORMATION!

Please read the entire manual carefully before starting to assemble and/or using this product. Follow the manual thoroughly and keep it for further reference.

FR: INFORMATIONS IMPORTANTES

Veillez lire attentivement l'ensemble du manuel avant de commencer à monter et/ou utiliser ce produit. Suivez rigoureusement le manuel et conservez-le pour toute consultation ultérieure.

LV: SVARĪGA INFORMĀCIJA!

Pirms šī izstrādājuma montāžas un/vai lietošanas uzsākšanas pilnībā izlasiet lietošanas pamācību. Stingri ievērojiet pamācības norādījumus un saglabājiet to turpmākai lietošanai.

LT: SVARBI INFORMACIJA!

Prieš pradėdami montuoti gaminį ir (arba) juo naudotis, prašome atidžiai perskaityti visą vadovą. Atidžiai skaitykite vadovą ir turėkite jį su savimi, kad galėtumėte toliau vadovautis jo nuorodomis.

EE: OLULINE TEAVE!

Enne kui alustate toote kokku panemist ja/või kasutamist, lugege see kasutusjuhend hoolikalt läbi. Järgige täpselt juhendis toodud juhiseid ja hoidke juhend alles.

BY: ВАЖНАЯ ИНФОРМАЦИЯ!

Внимательно и полностью прочитайте это руководство, прежде чем приступать к сборке или использованию этого изделия. Следуйте всем инструкциям этого руководства и сохраните его на будущее для справки.

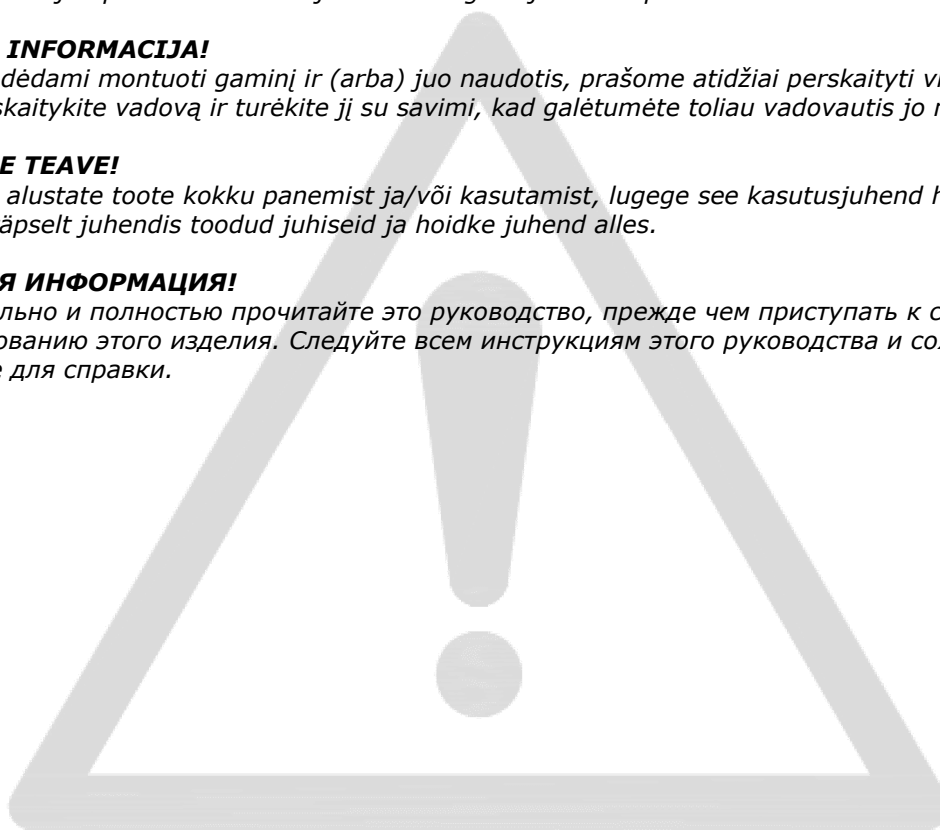

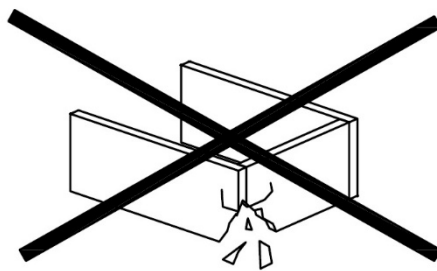
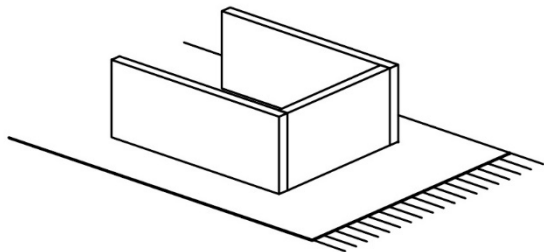

EN: WARNING TO AVOID SCRATCHES!

In order to avoid scratching this furniture should be assembled on a soft layer - could be a rug.

FR: AVERTISSEMENT POUR ÉVITER LES RAYURES

Afin d'éviter les rayures, ce meuble doit être monté sur une surface souple (un tapis, par exemple).

LV: BRĪDINĀJUMS PAR SKRĀPĒJUMIEM!

Lai nesaskrāpētu šo izstrādājumu, veiciet montāžu uz mīkstas pamatnes, piemēram, paklāja.

LT: ĮSPĖJIMAS, KAD IŠVENGTUMĖTE ĮBRĖŽIMŲ!

Šio baldos nesubraižysite, jei jį surinksite ant švelnaus paviršiaus, pavyzdžiui, kilimo.

EE: HOIATUS KRIIMUSTUSTE VÄLTIMISEKS!

Kriimustuste tekkimise vältimiseks mööblile tuleb see kokku panna pehmel pinnal, nt kaltsuvaibal.

BY: ПРЕДУПРЕЖДЕНИЕ ОТНОСИТЕЛЬНО ЦАРАПИН!

Во избежание нанесения царапин, сборку этой мебели необходимо выполнять на мягкой поверхности, например на ковре.





EN: GENERAL INSTRUCTION FOR FURNITURE MADE OF WOOD OR WOOD COMPOSITES SUCH AS MELAMINE, LAMINATE OR VENEER SURFACES!

*Wipe clean with a damp cloth. Use only water or a gentle detergent.
Wipe dry with a clean cloth.*

FR: INSTRUCTIONS GÉNÉRALES POUR LE MOBILIER CONSTITUÉ DE BOIS OU DE COMPOSITES DE BOIS (COMME LES SURFACES EN MELAMINÉ, STRATIFIÉ OU PLACAGE)

*Nettoyer à l'aide d'un chiffon humide. Utiliser uniquement de l'eau ou un détergent doux.
Essuyer à l'aide d'un chiffon propre.*

LV: VISPĀRĒJI NORĀDĪJUMI MĒBELĒM NO KOKA VAI KOKSNES KOMPOZĪTIEM, PIEMĒRAM, MELAMĪNA, LAMINĀTA VAI FINIERA VIRSMĀM!

*Noslaukiet ar mitru drānu. Lietojiet tikai ūdeni vai maigu mazgāšanas līdzekli.
Nosusiniet ar tīru drānu.*

LT: BALDŲ IŠ MEDIENOS AR MEDIENOS KOMPOZITO, DENGTO MELAMINU, LAMINATU AR PLONU FANEROS SLUOKSNIU, BENDRIEJI VALYMO NURODYMAI!

*Valykite drėgnu skudurėliu. Naudokite tik vandenį arba švelnų valiklį.
Nusausinkite švari skudurėliu.*

EE: PUIDUST VÕI MITMEKIHILISEST PUIDUST, NAGU MELAMIINIST, LAMINAADIST VÕI VINEERIST MÖÖBLI ÜLDJUHISED!

*Kasutage puhastamiseks niisket lappi. Kasutage ainult vett või õrnatoimelist puhastusvahendit.
Pühkige puhta lapiga kuivaks.*

BY: ОБЩИЕ УКАЗАНИЯ ОТНОСИТЕЛЬНО МЕБЕЛИ, ИЗГОТОВЛЕННОЙ ИЗ ДЕРЕВА ИЛИ ДРЕВЕСНЫХ КОМПОЗИЦИОННЫХ МАТЕРИАЛОВ, ТАКИХ КАК МЕЛАМИН, ЛАМИНАТ ИЛИ ШПОН!

*Очистите изделие чистой влажной тканью. Используйте мягкодействующее моющее средство.
Вытрите досуха чистой тряпкой.*

EN: IMPORTANT!

It is important that any product which is assembled using any kind of screw is re-tightened 2 weeks after assembly, and once every 3 months - in order to assure stability through-out the lifespan of the product.

FR: IMPORTANT

Il est important que tout produit monté à l'aide de vis soit resserré 2 semaines après son montage, puis tous les 3 mois, afin de garantir sa stabilité durant tout son cycle de vie.

LV: SVARĪGI!

Ir svarīgi, lai jebkuram produktam, kas tiek uzstādīts ar jebkādu skrūvju palīdzību, skrūves tiktu atkārtoti pievilktas 2 nedēļas pēc montāžas, pēc tam – reizi 3 mēnešos, tā nodrošinot stabilitāti visā izstrādājuma kalpošanas laikā.

LT: SVARBU!

Bet kokį varžtais tvirtinamą gaminį 2 savaites po surinkimo bei kas 3 mėnesius reikia papildomai suveržti – taip užtikrinamas naudojamo gaminio stabilumas.

EE: TÄHTIS!





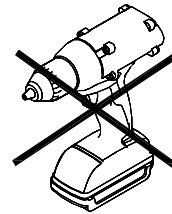
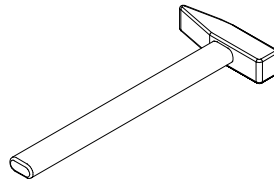
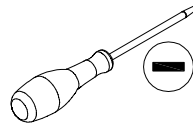
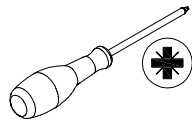

Oluline on, et toote kruvisid pingutataks 2 nädalat pärast kokkupanekut ja seejärel iga 3 kuu järel, et tagada stabiilsus kogu toote eluea jooksul.

BY: ВАЖНО!

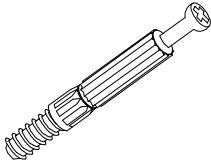
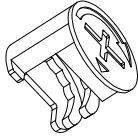
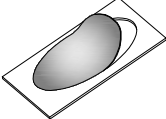
В любом изделии, собранном с использованием винтов любого типа, необходимо через 2 недели после сборки и в дальнейшем каждые 3 месяца подтягивать винты, чтобы обеспечить прочность изделия в течение срока эксплуатации.

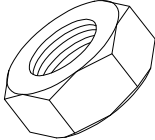
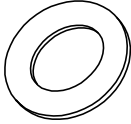
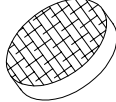
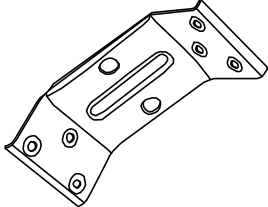
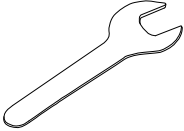
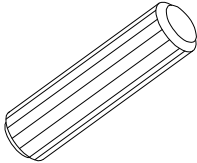
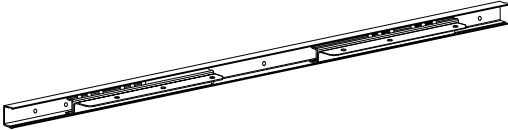
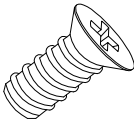

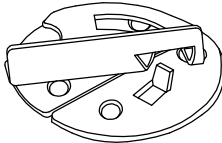

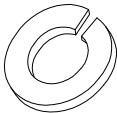
<p>A x 8</p>  <p>Ø6,5x36,5 mm</p>	<p>B x 8</p>  <p>Ø15x12 mm</p>	<p>C x 8</p>  <p>Ø20 mm</p>	<p>D x 24</p>  <p>Ø4x16 mm</p>
<p>E x 8</p>  <p>Ø10/17 mm</p>	<p>F x 8</p>  <p>Ø10/Ø20 mm</p>	<p>G x 4</p>  <p>Ø24x3 mm</p>	<p>H x 4</p>  <p>156x70x32 mm</p>
<p>J x 1</p>  <p>17 mm</p>	<p>K x 4</p>  <p>Ø8x30 mm</p>	<p>L x 2</p>  <p>750x34x37 mm</p>	
<p>M x 34</p>  <p>Ø6x13 mm</p>	<p>N x 8</p>  <p>Ø2.5x12 mm</p>	<p>P x 2</p>  <p>Ø48x13 mm</p>	<p>Q x 6</p>  <p>Ø8x22 mm</p>
<p>R x 8</p>  <p>Ø10/Ø18 mm</p>			

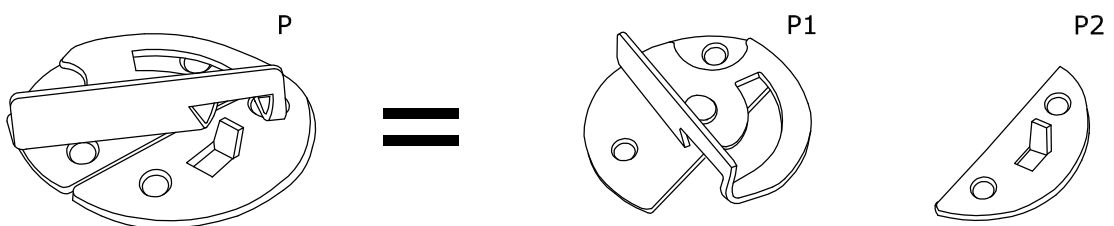
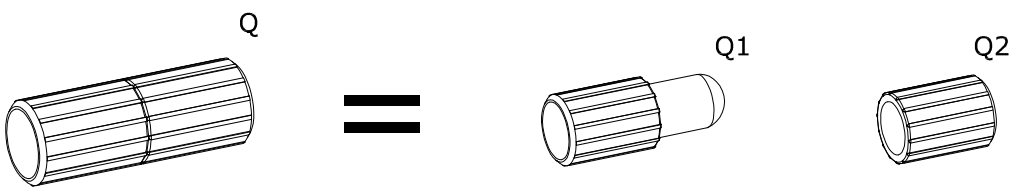

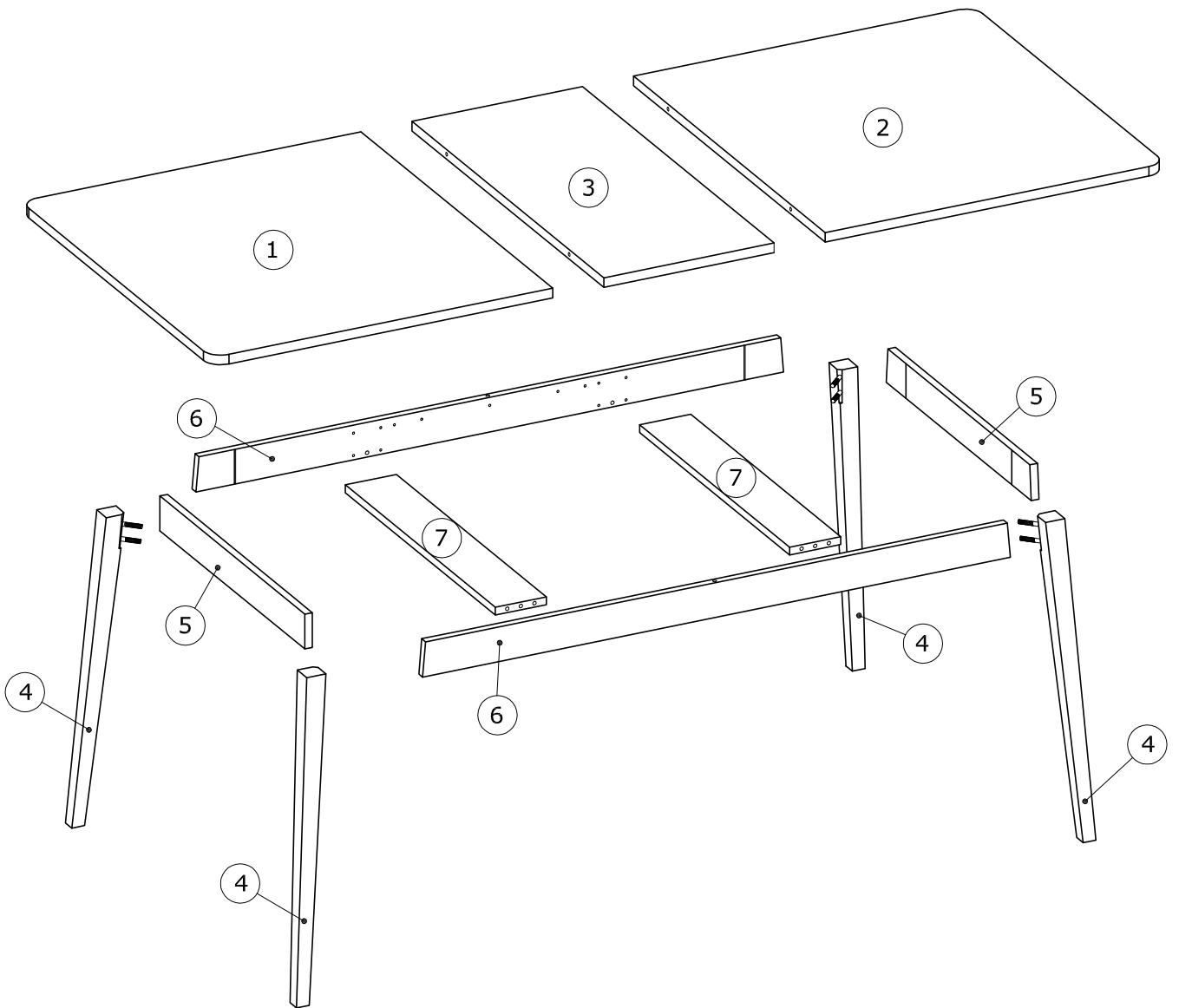
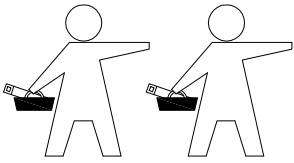

Box 1/2 :

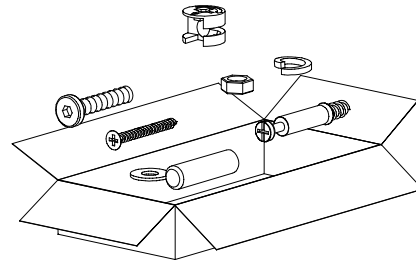
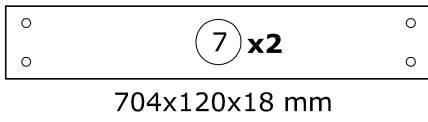
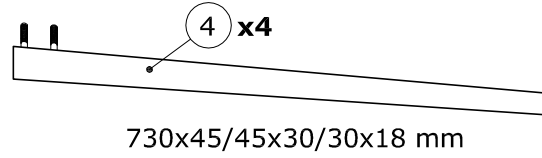
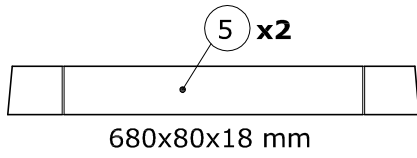
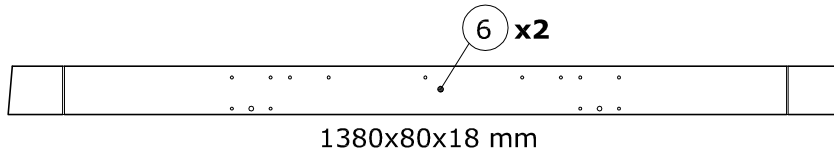



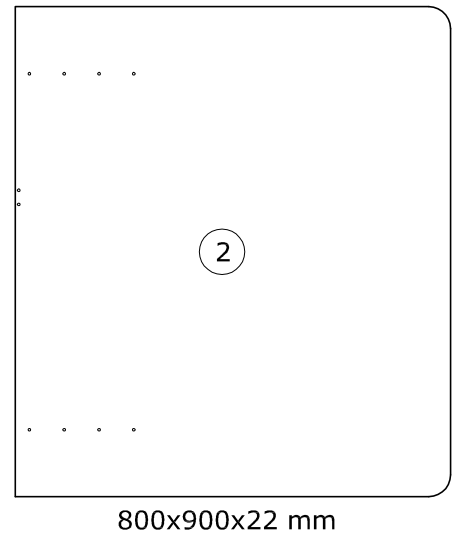
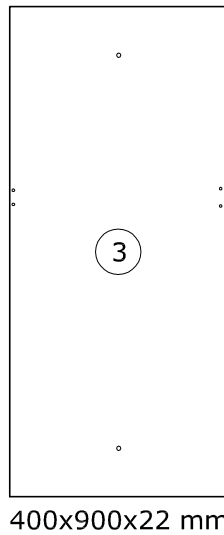
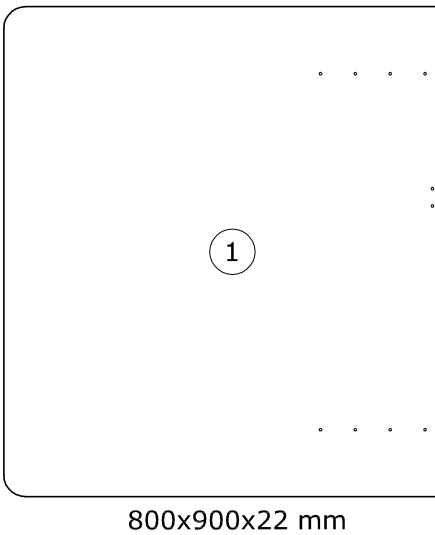

Box 2/2 :

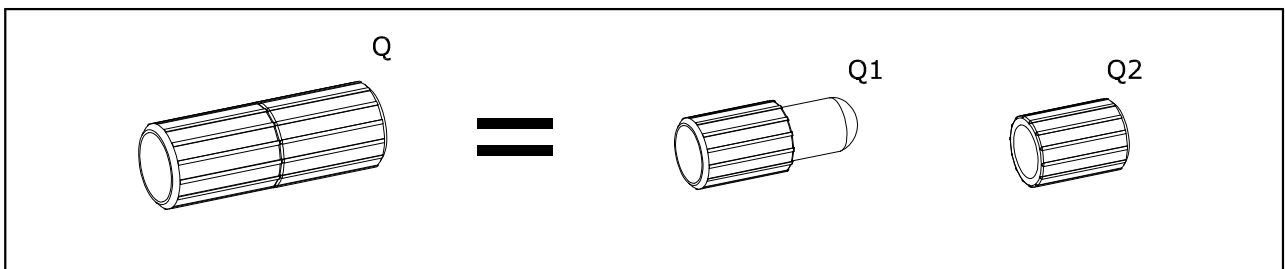
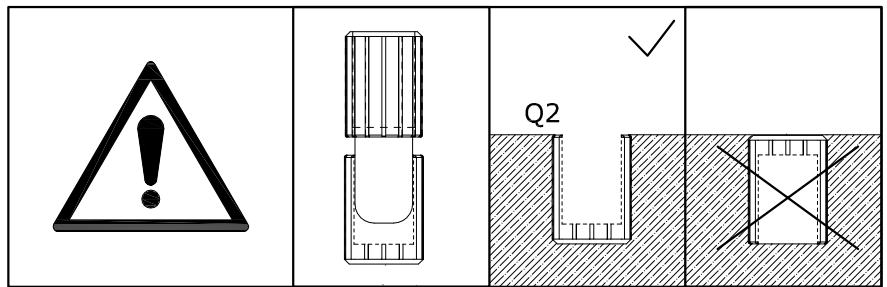
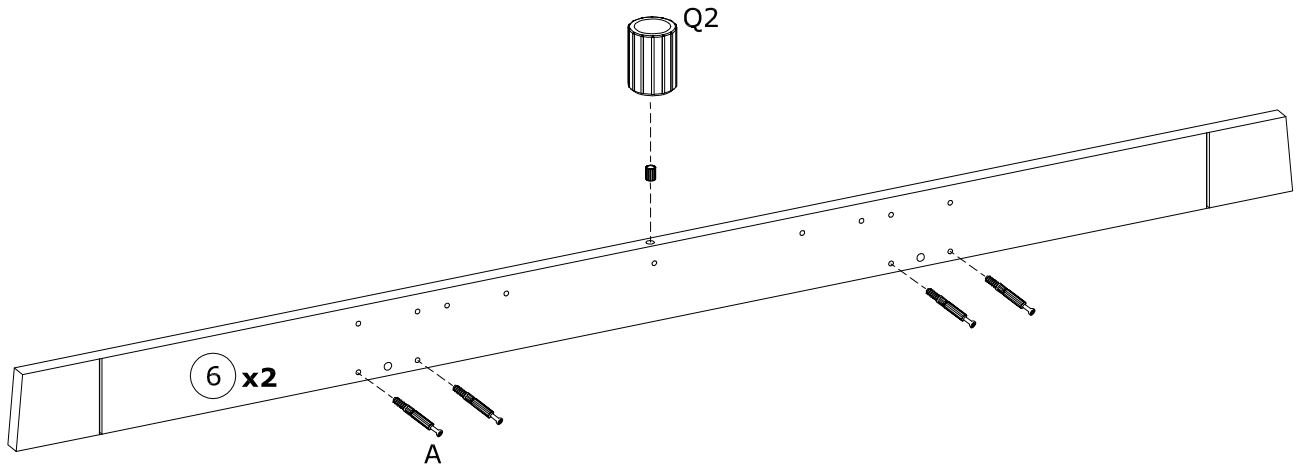
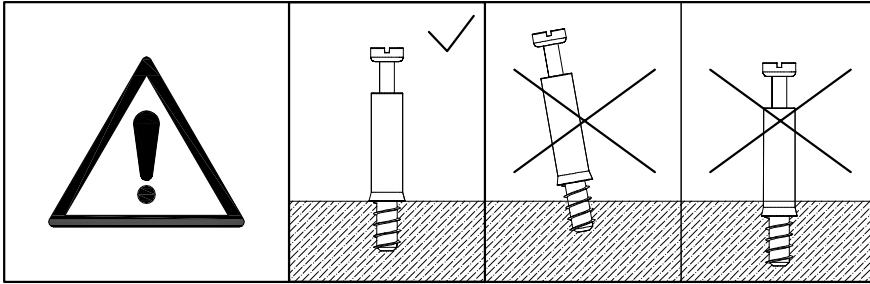
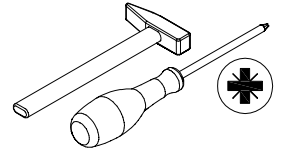
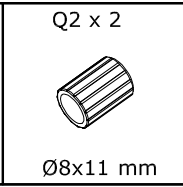
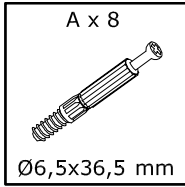

1

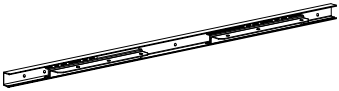

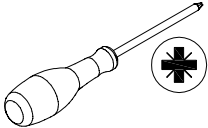

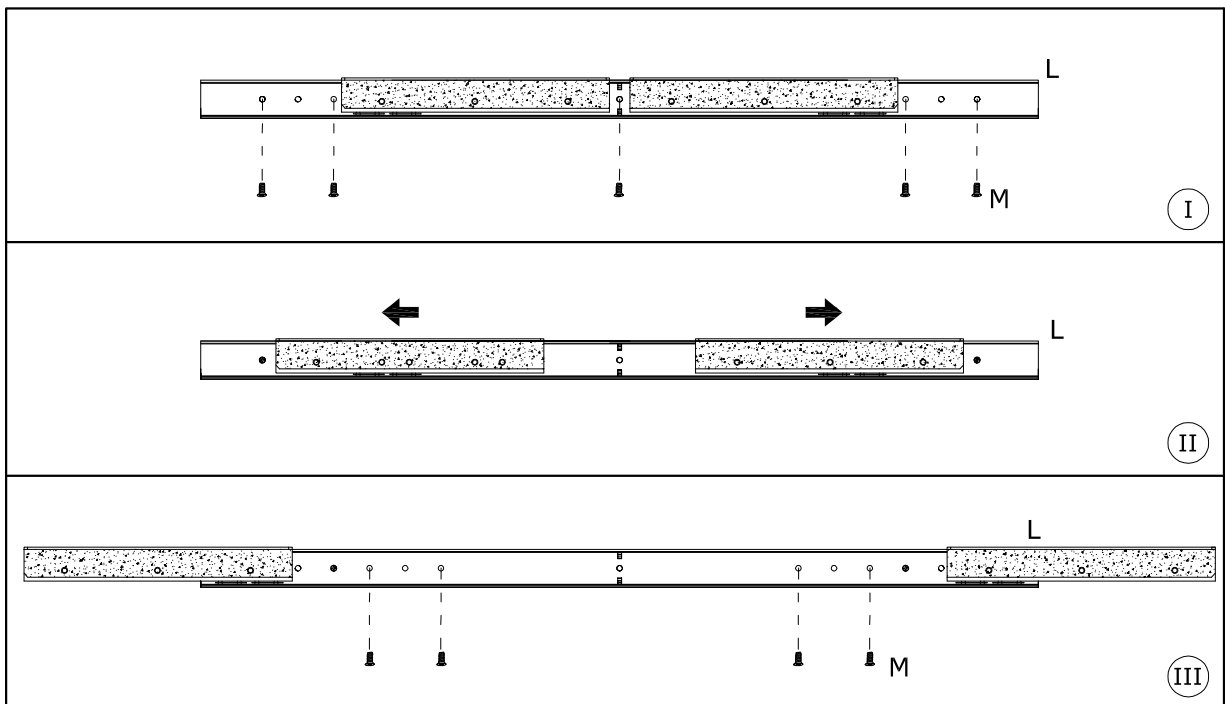
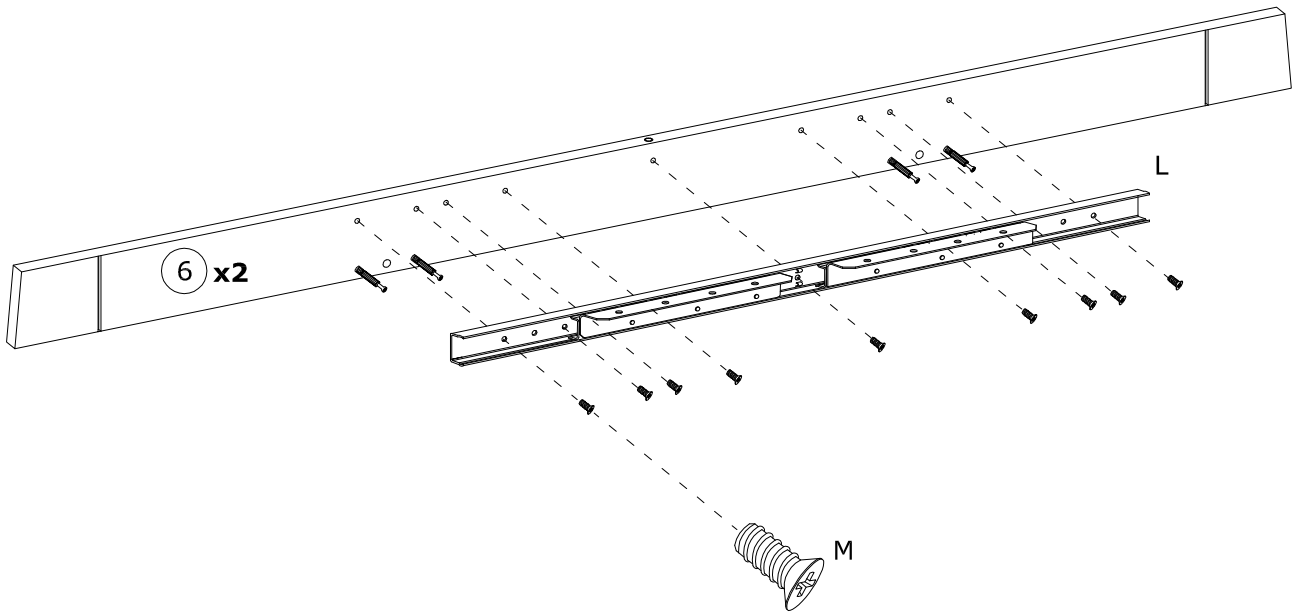

2

<p>L x 2</p>  <p>750x34x37 mm</p>	<p>M x 18</p>  <p>Ø6x13 mm</p>	 
--	---	---

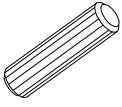

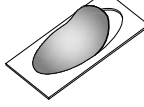
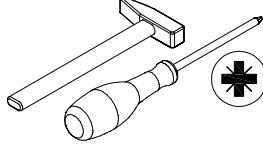
3



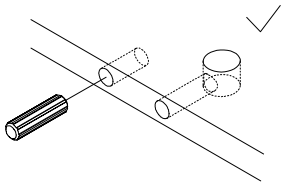
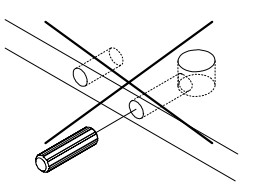

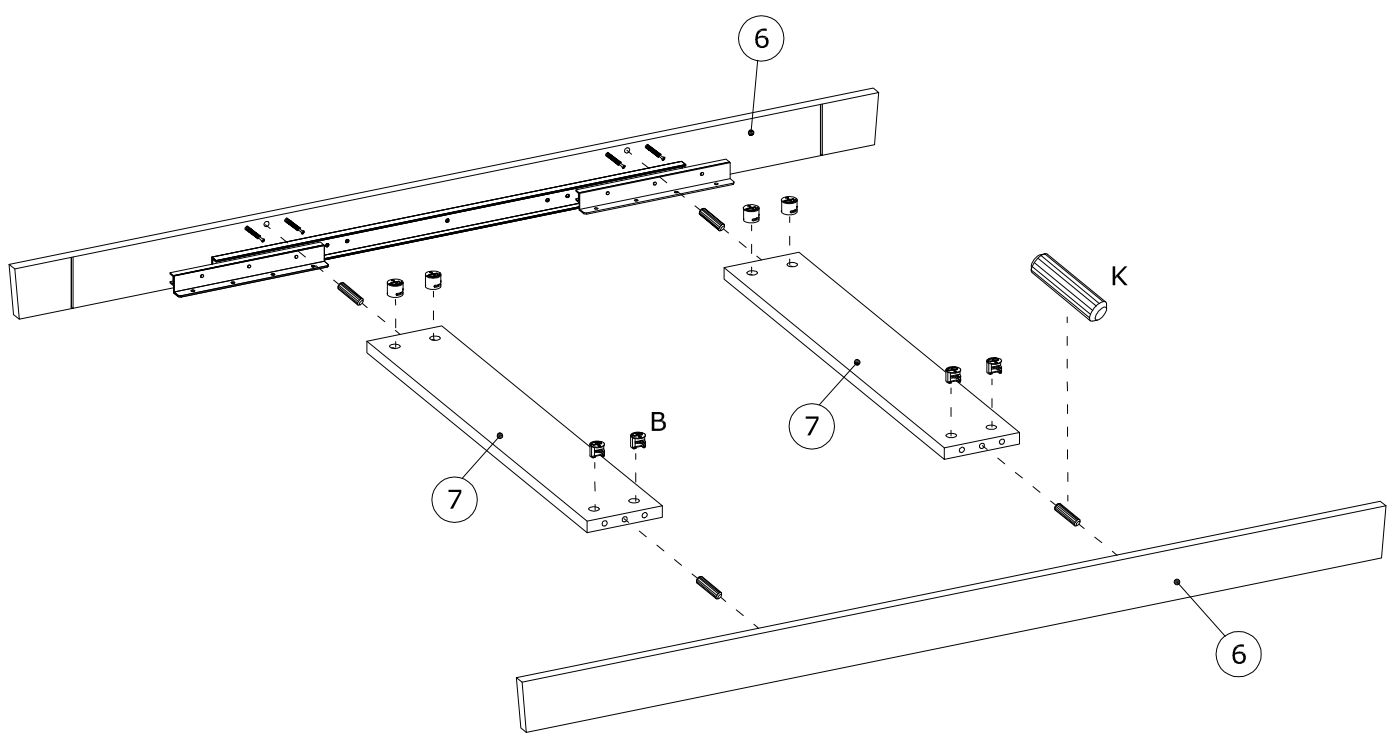
<p>K x 4</p>  <p>Ø8x30 mm</p>	<p>B x 8</p>  <p>Ø15x12 mm</p>	<p>C x 8</p>  <p>Ø20 mm</p>	 
--	---	--	---

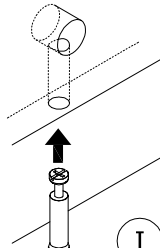
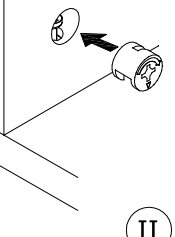
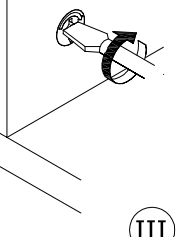
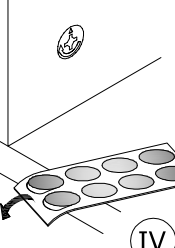
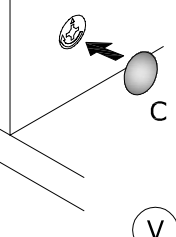
		
---	--	---



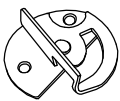

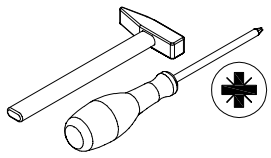
	 <p>I</p>	 <p>II</p>	 <p>III</p>	 <p>IV</p>	 <p>V</p>
---	--	---	---	---	--

4

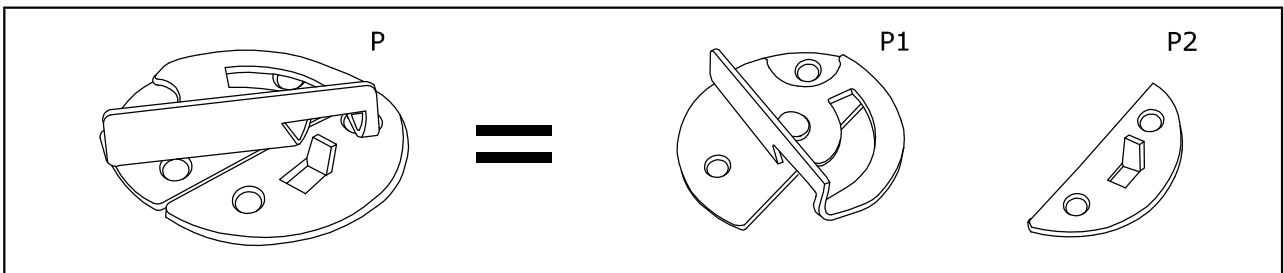
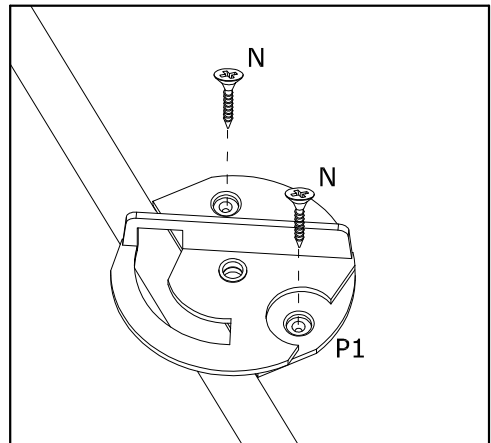
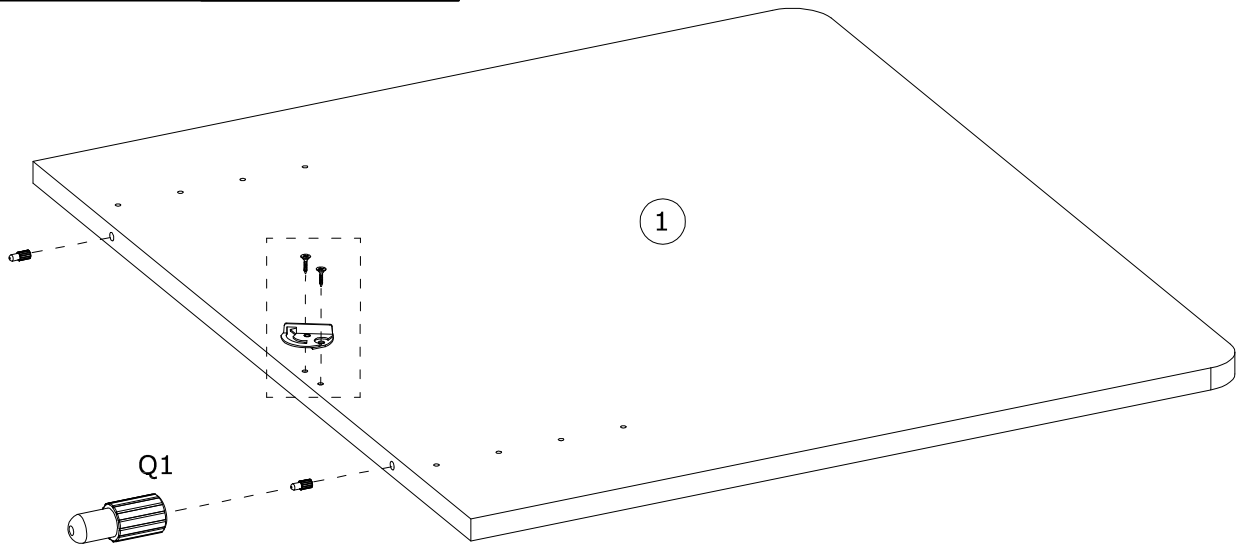
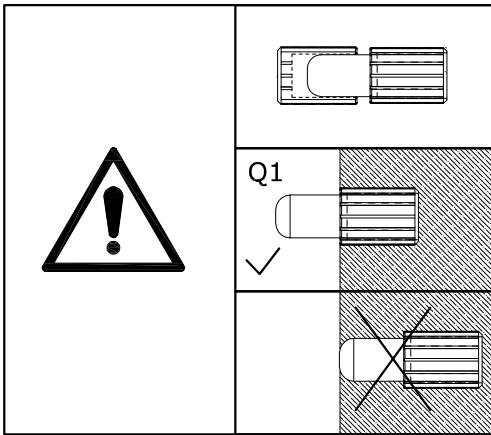
N x 2  Ø2.5x12 mm	P1 x 1  46x30x13 mm	Q1 x 2  Ø8x20 mm	 
--	--	---	--



5

<p>N x 2</p>  <p>Ø2.5x12 mm</p>	<p>P2 x 1</p>  <p>46x18x8 mm</p>	<p>Q2 x 2</p>  <p>Ø8x11 mm</p>	 
--	---	---	---

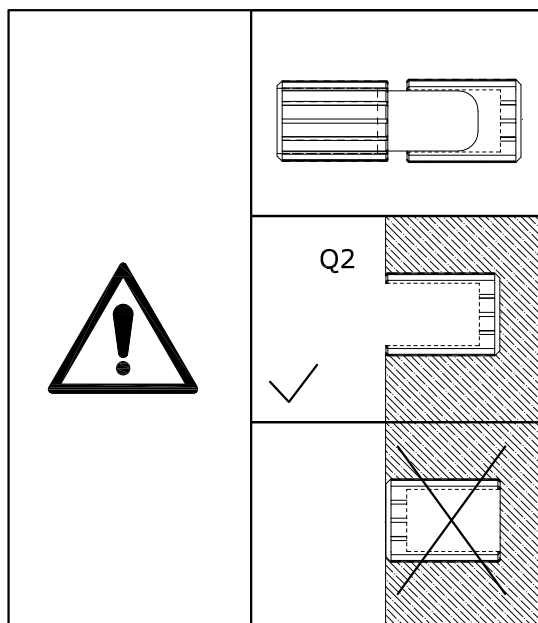
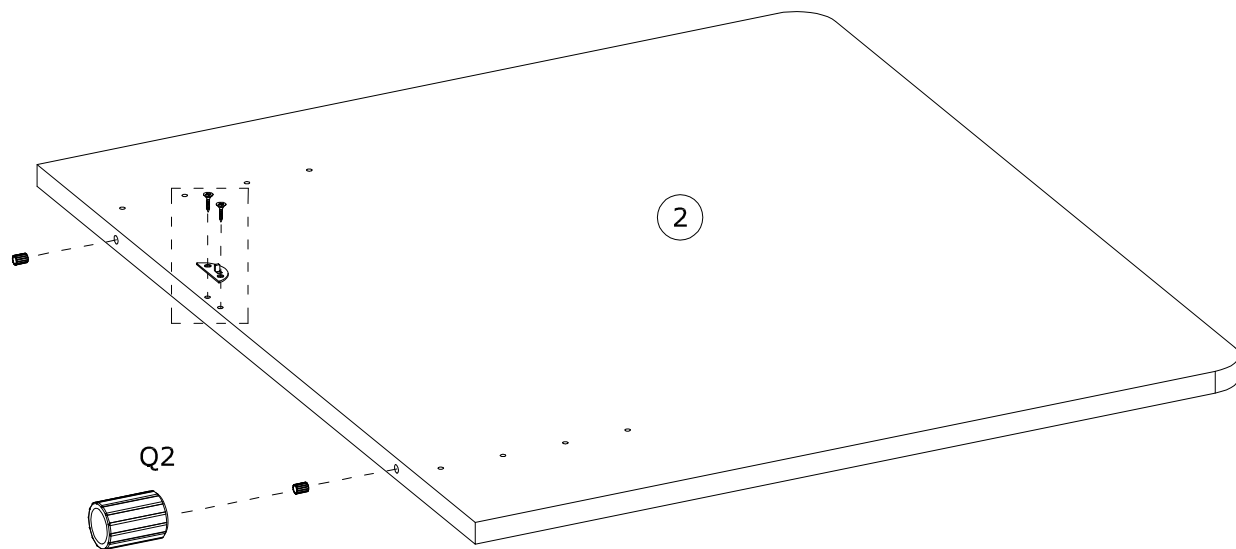
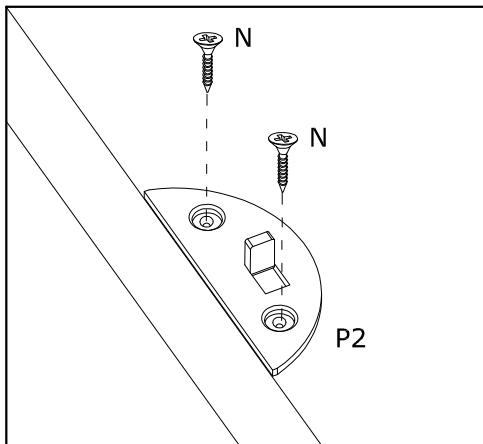

6

<p>N x 4</p>  <p>Ø2.5x12 mm</p>	<p>P1 x 1</p>  <p>46x30x13 mm</p>	<p>P2 x 1</p>  <p>46x18x8 mm</p>	 
--	--	---	---

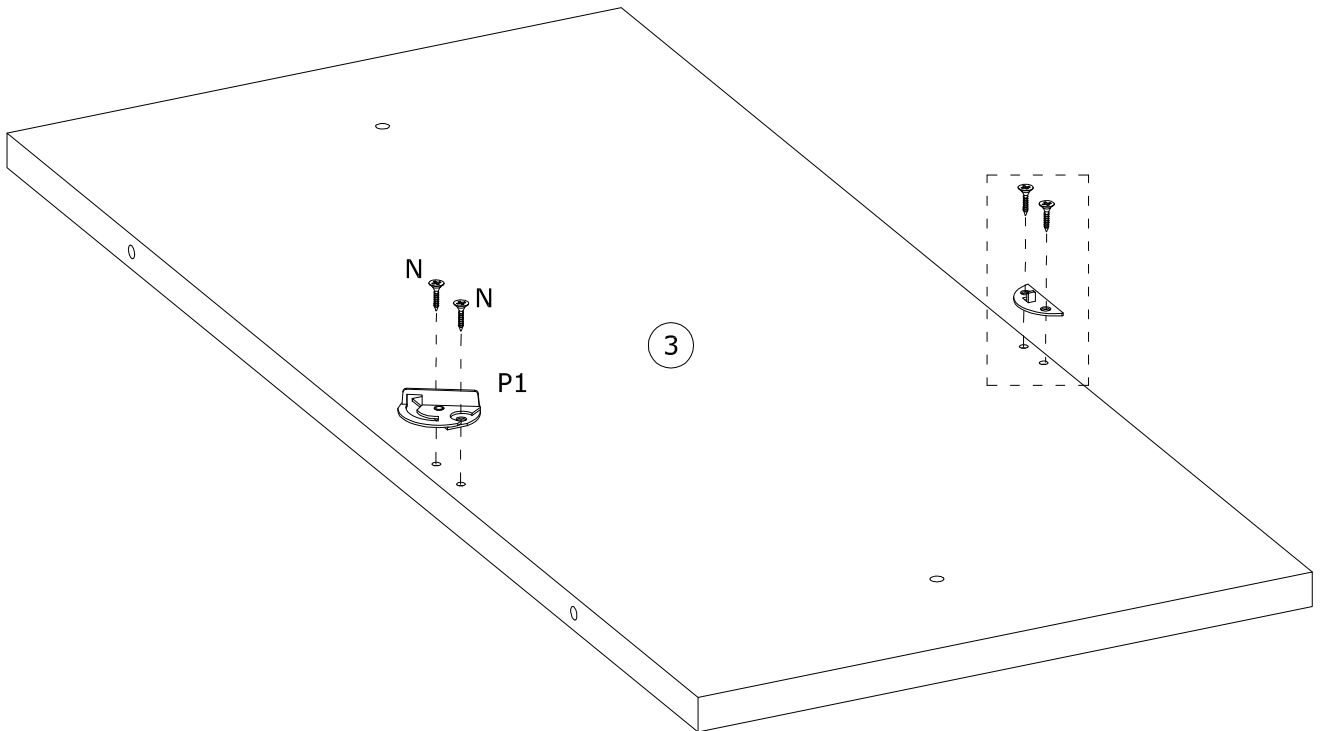
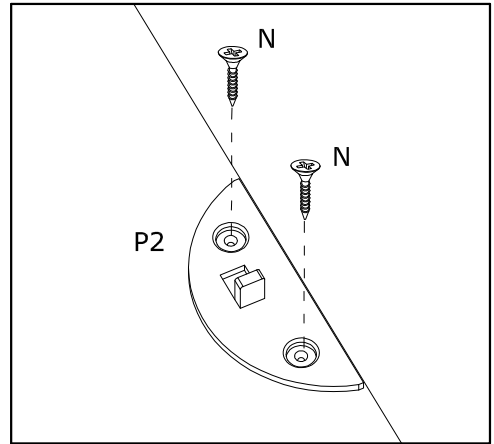

7

Q1 x 4  Ø8x20 mm	Q2 x 2  Ø8x11 mm	
---	---	---

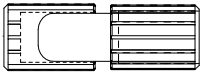
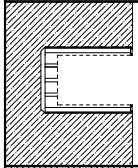
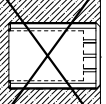
	
	 Q2 ✓
	

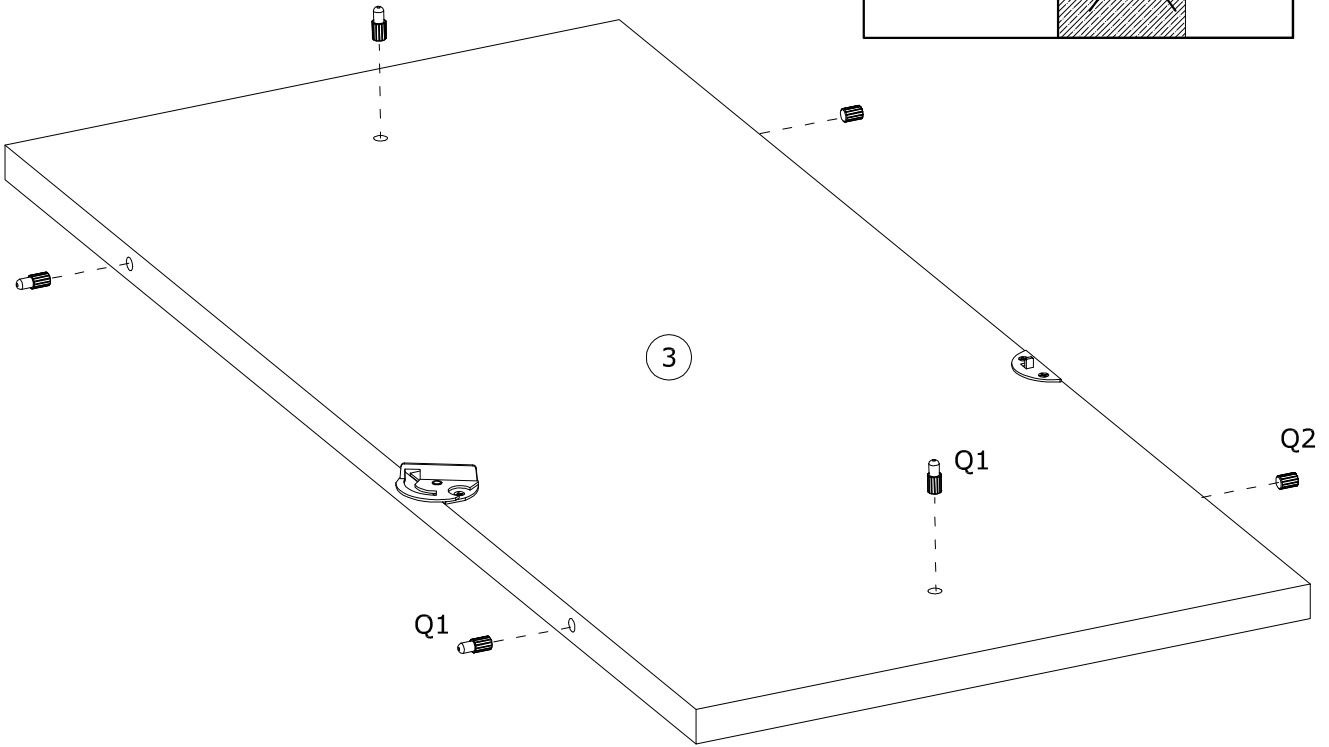

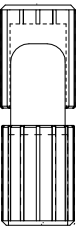
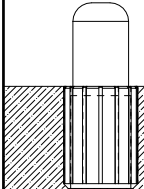
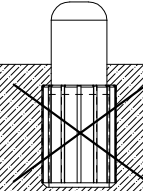
		✓ Q1 	
---	---	---	---

8

M x 16



Ø6x13 mm

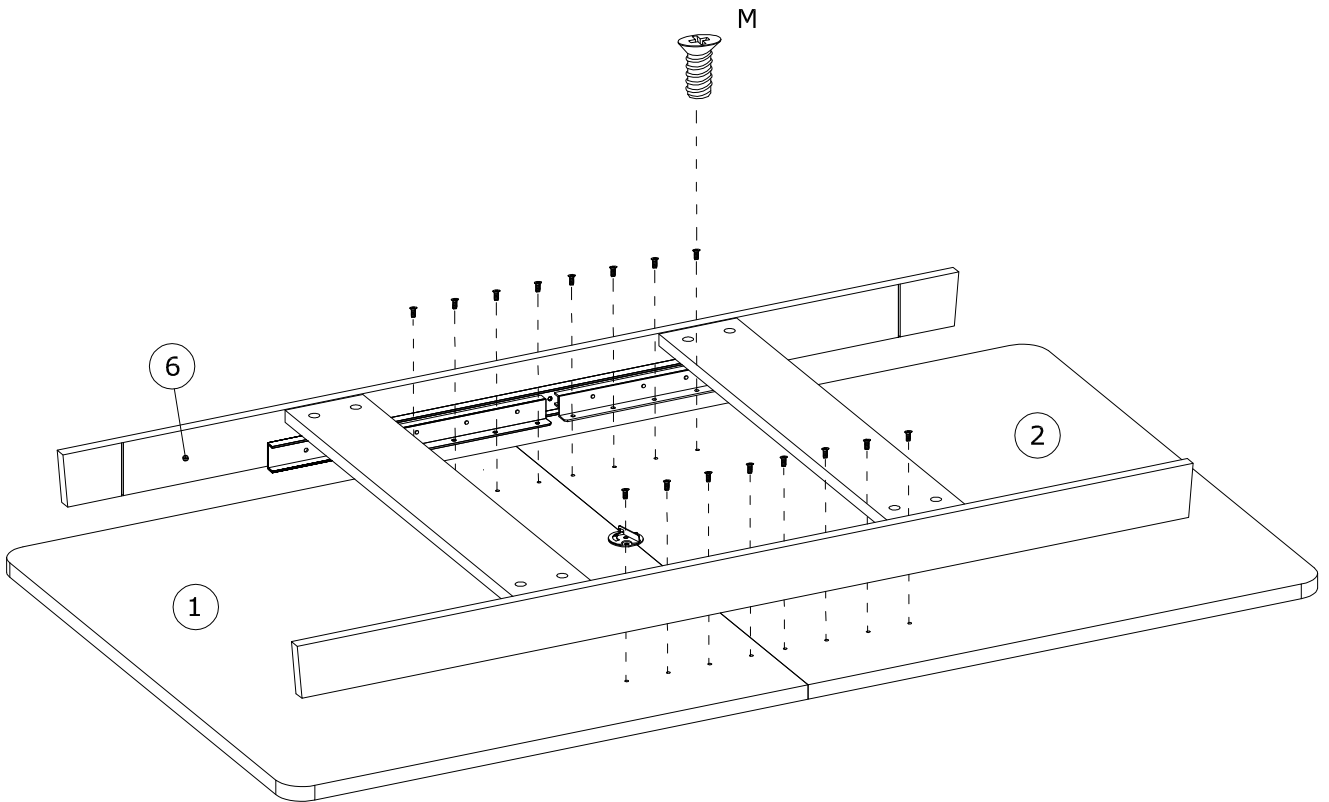
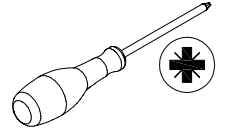



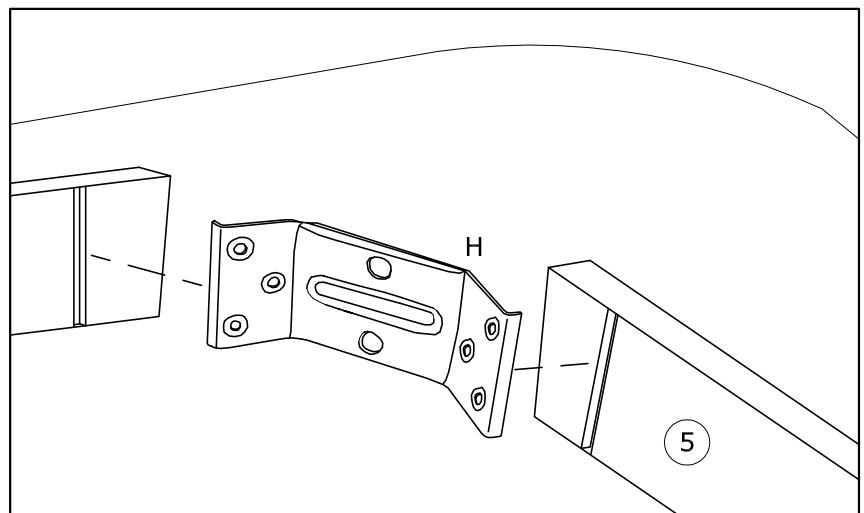
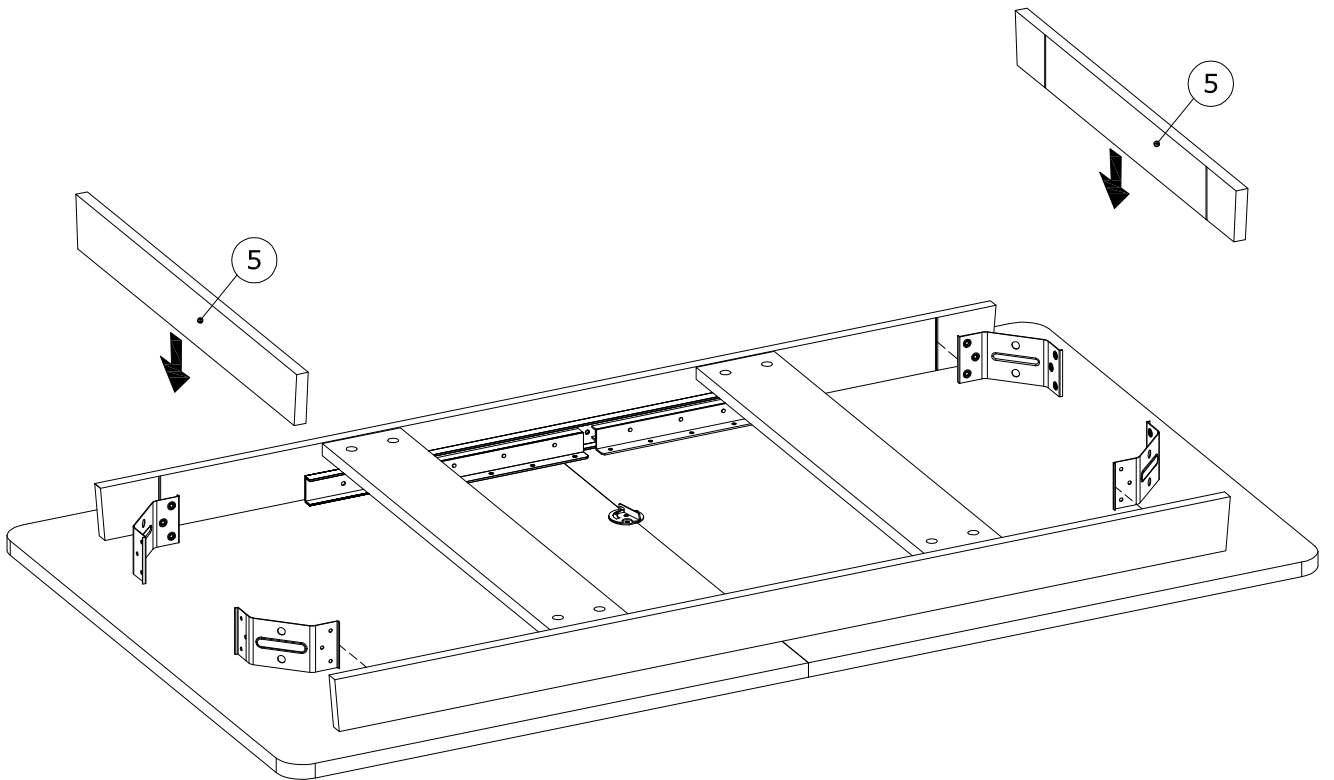
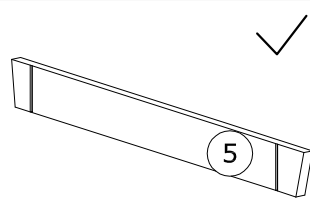
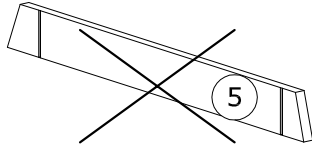

9

H x 4
156x70x32 mm



10

E x 8  Ø10/17 mm	F x 8  Ø10/Ø20 mm	J x 1  17 mm	R x 8  Ø10/Ø18 mm	
---	--	---	--	--

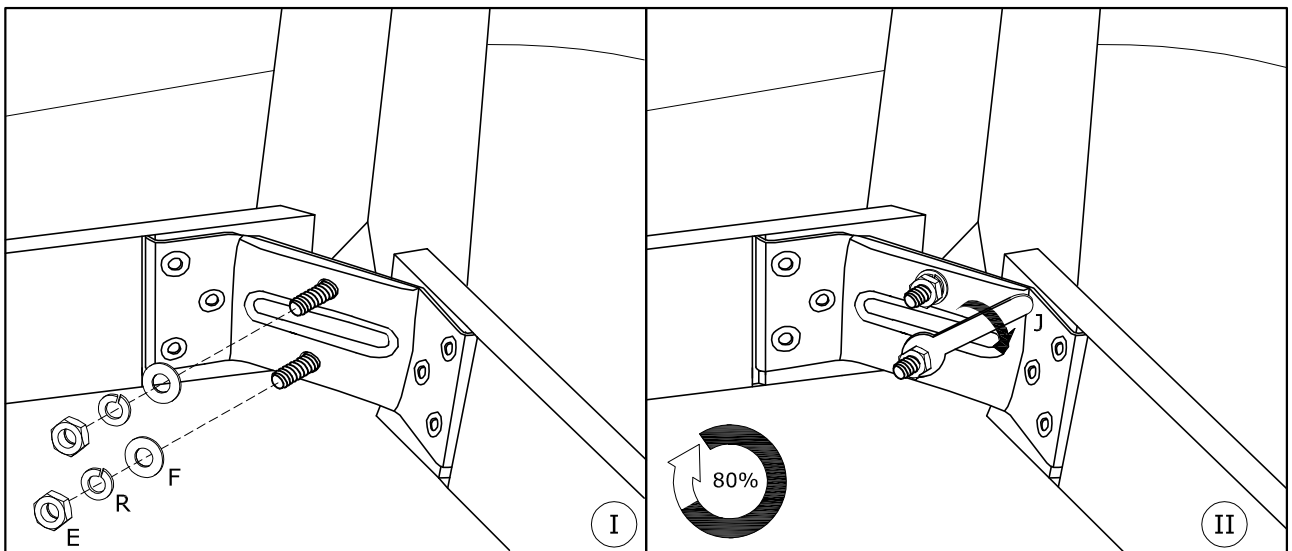
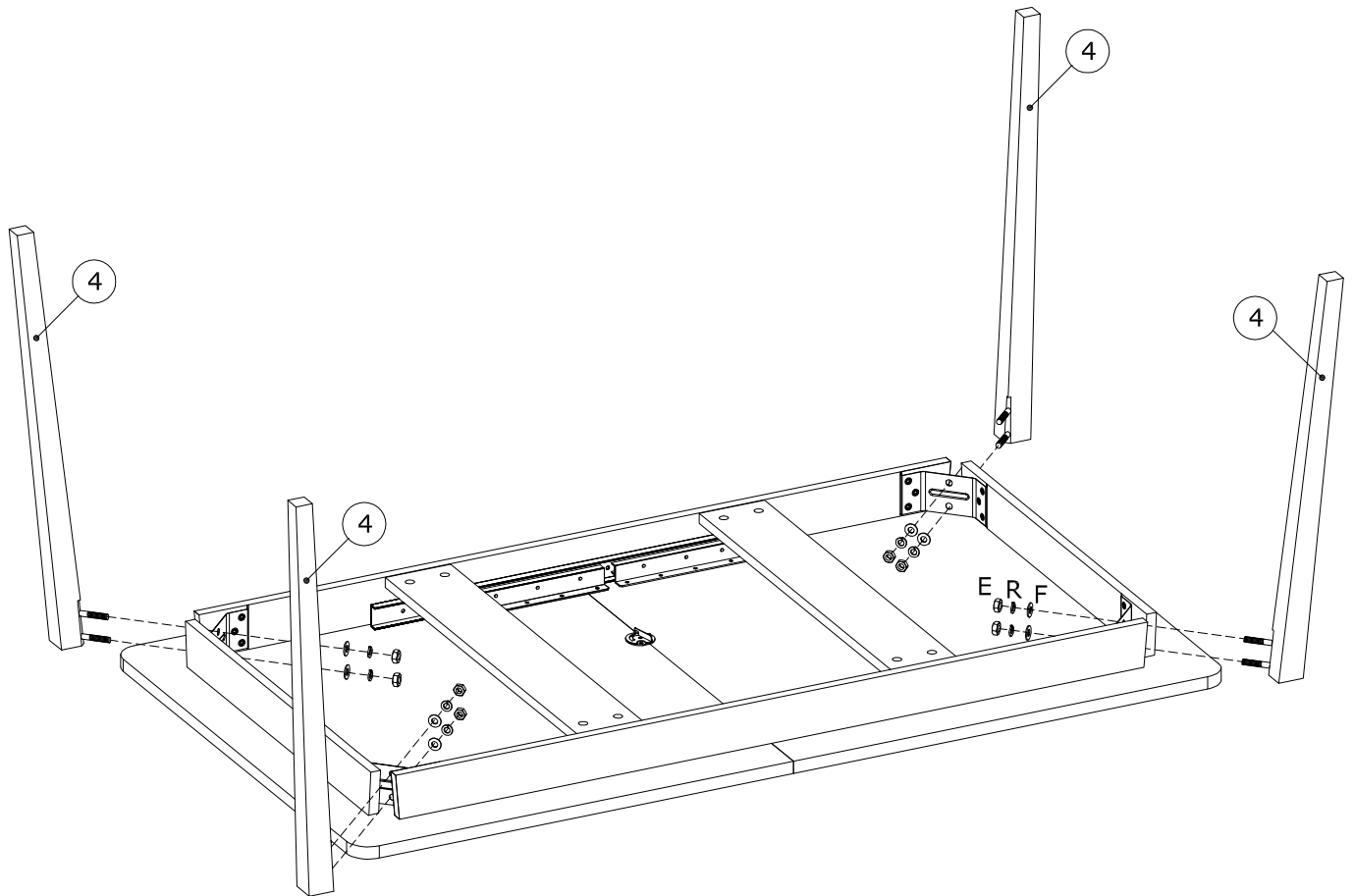

11

D x 24
Ø4x16 mm

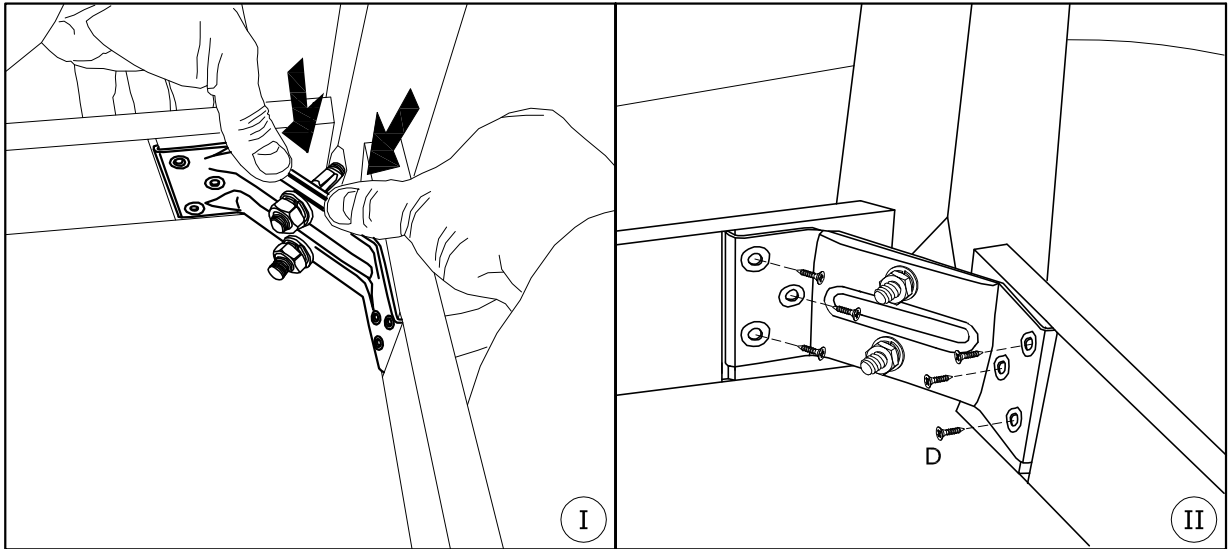
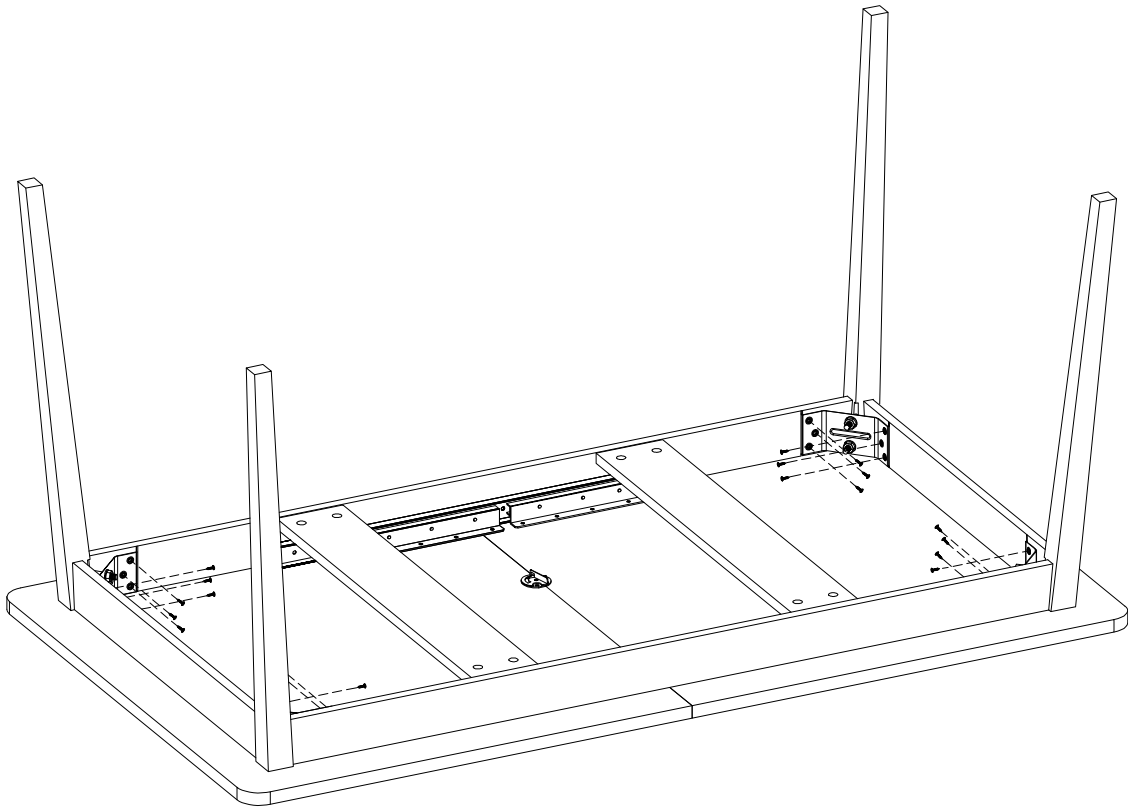
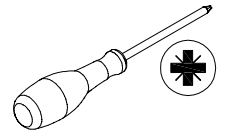

12

<p>G x 4</p>  <p>Ø24x3 mm</p>	<p>J x 1</p>  <p>17 mm</p>	
--	---	--

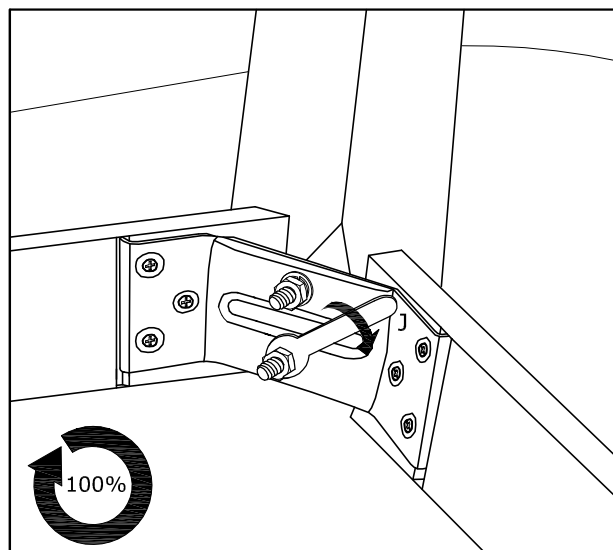
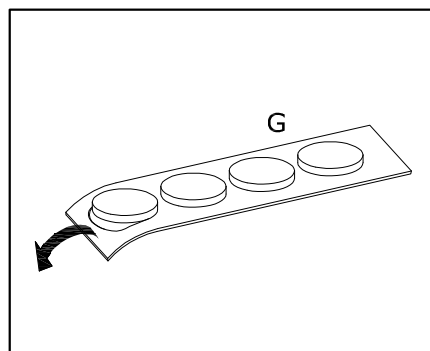
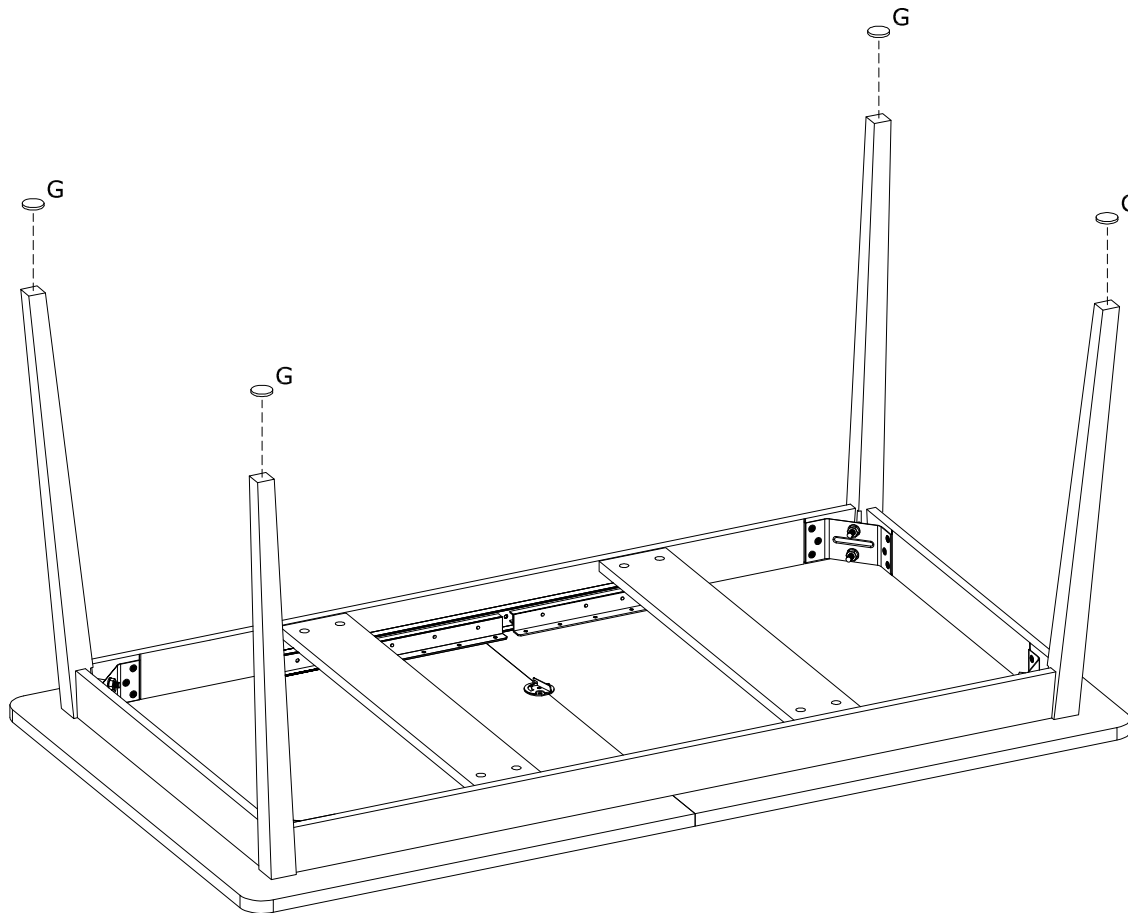

13

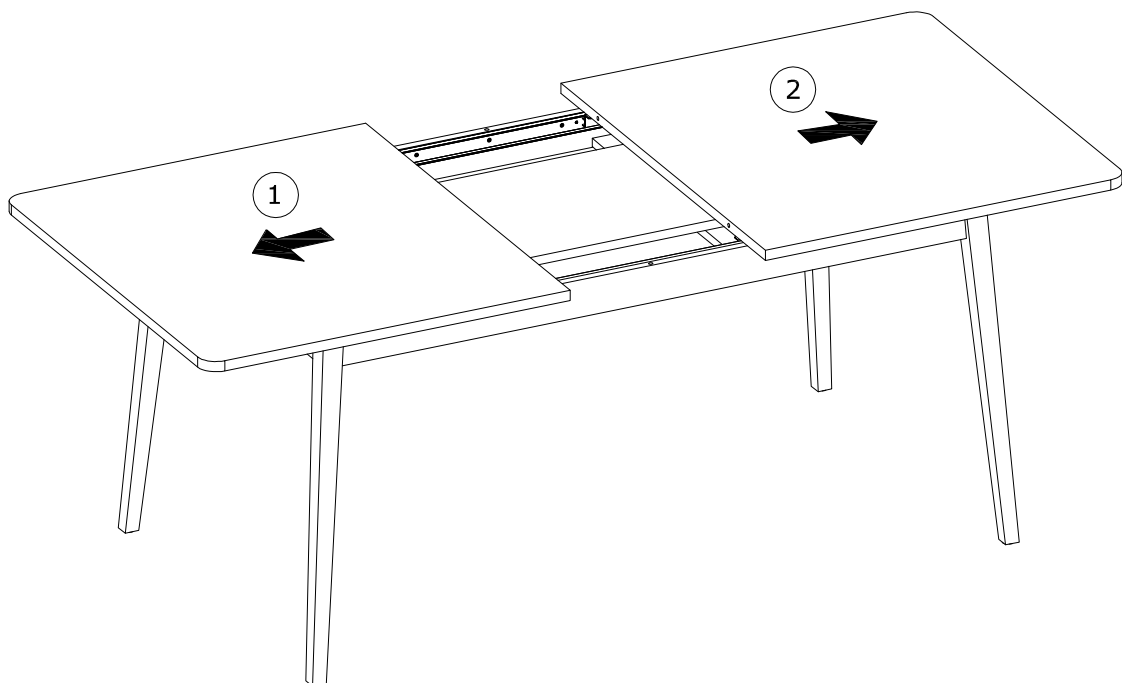
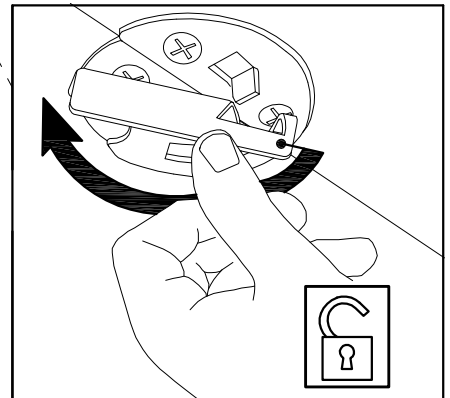
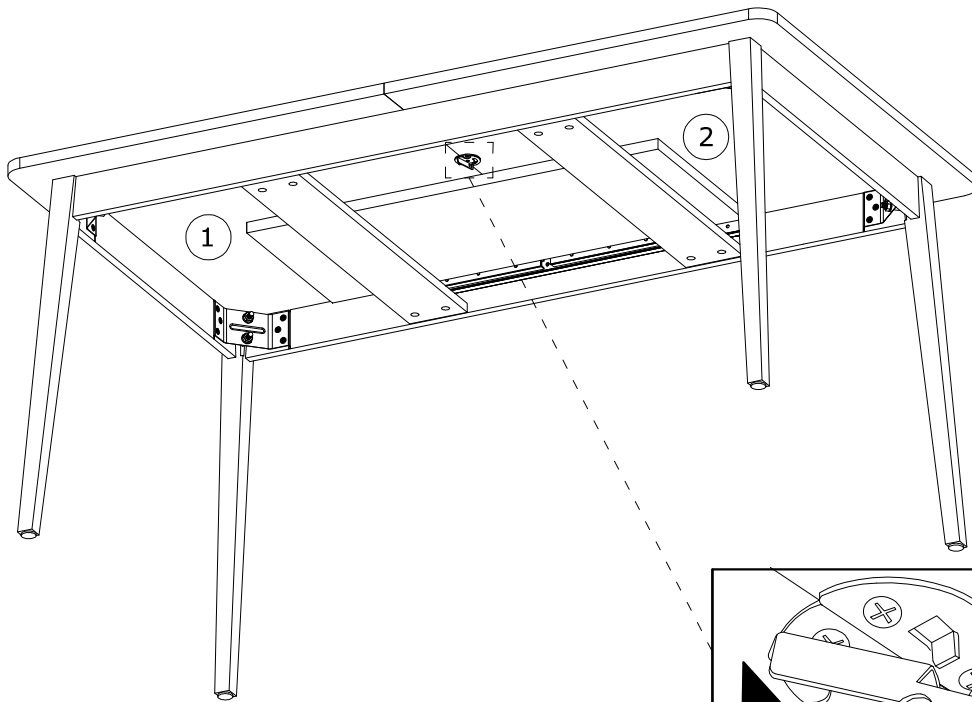

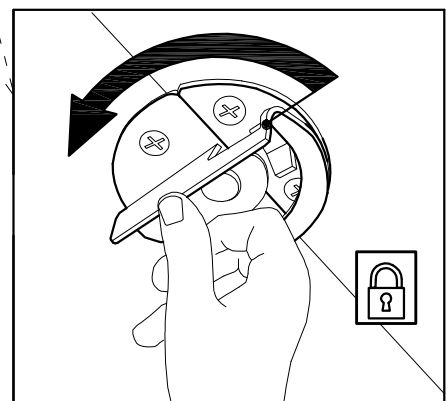
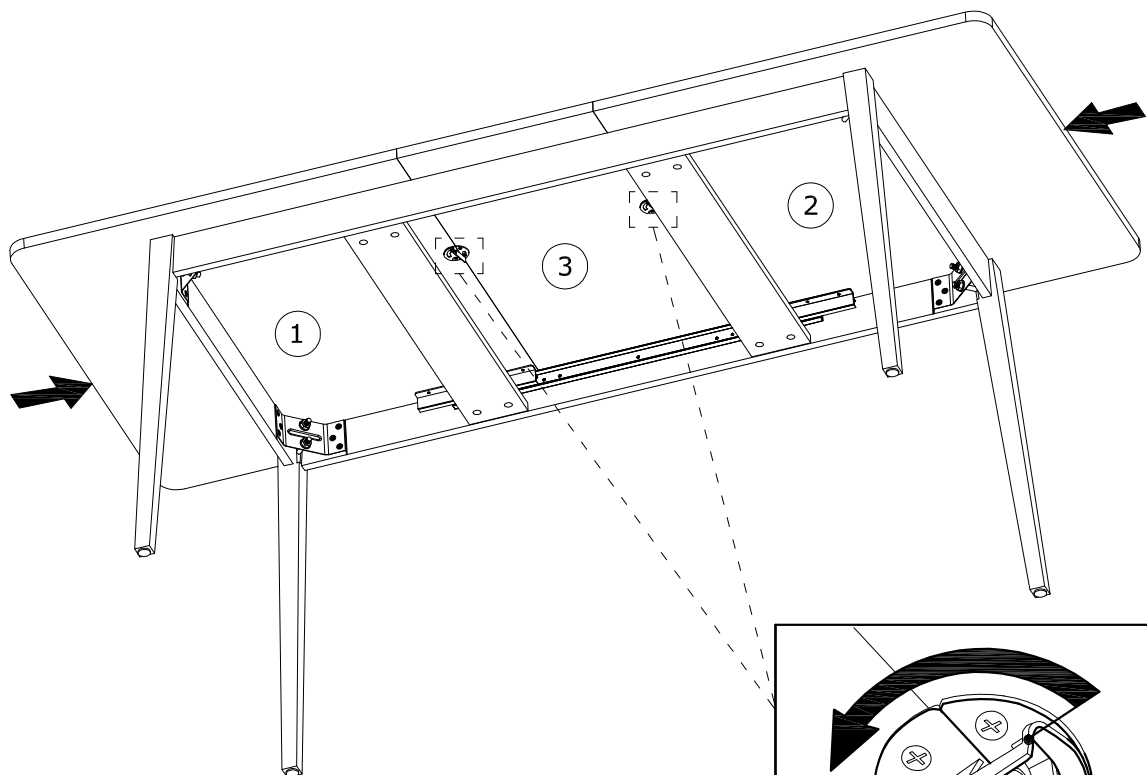
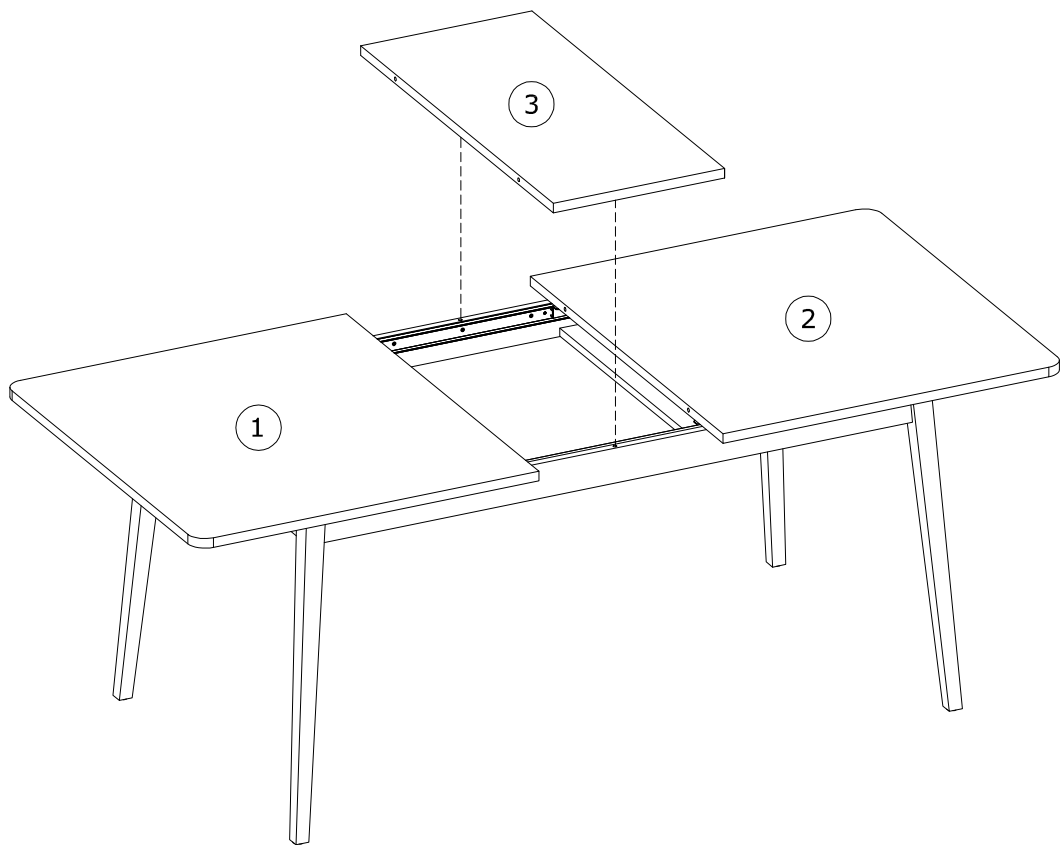

14

