

PORTMAN

131111/715-12-1025

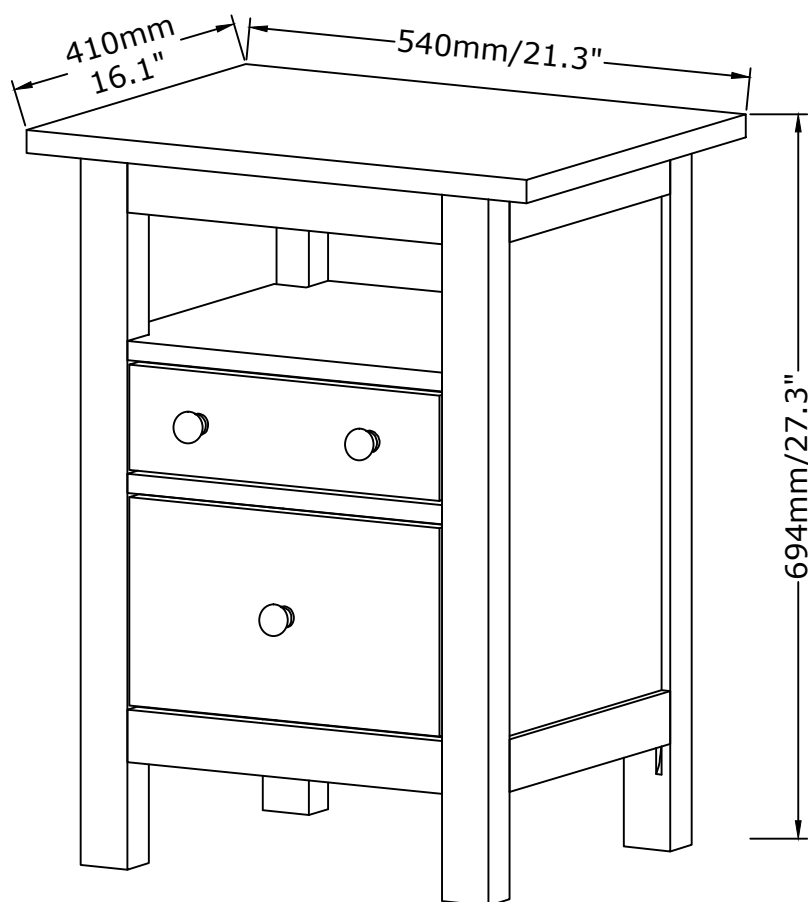

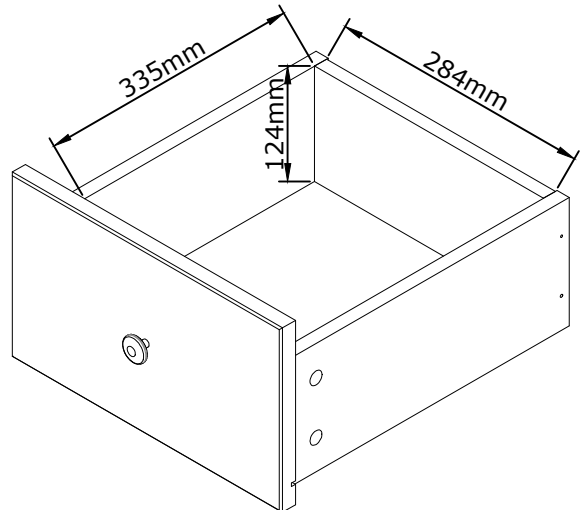

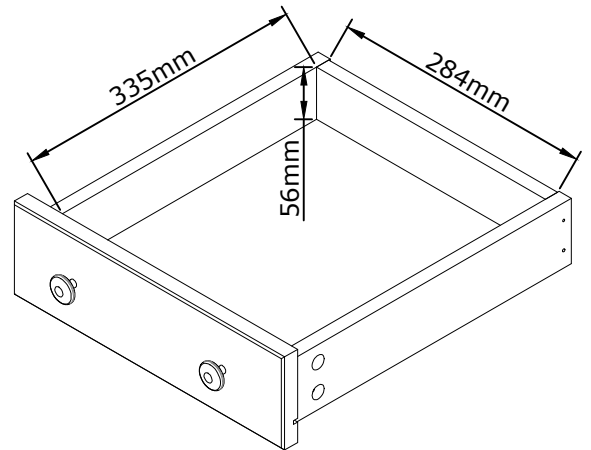
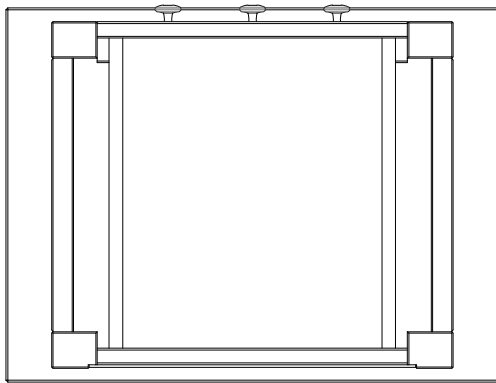
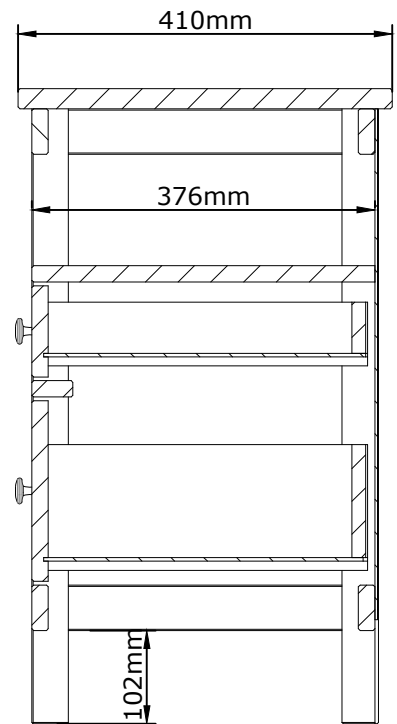
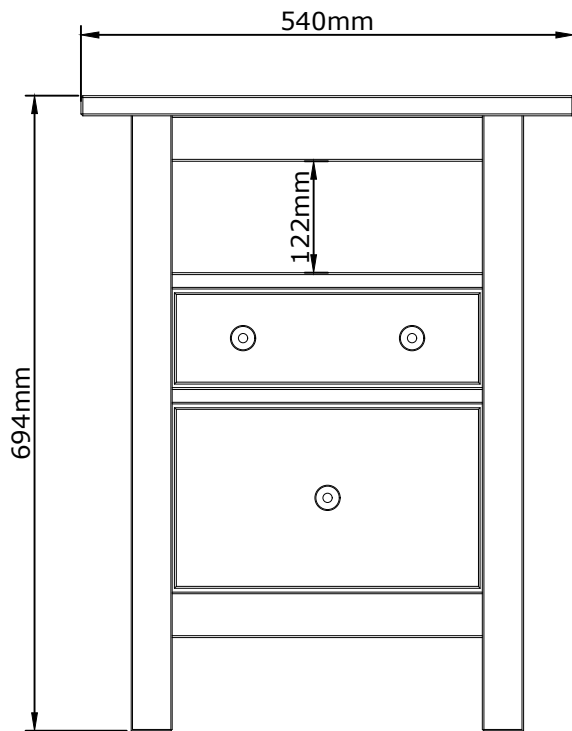
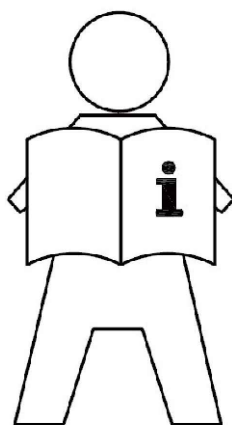

EN: IMPORTANT INFORMATION!

Please read the entire manual carefully before starting to assemble and/or using this product. Follow the manual thoroughly and keep it for further reference.

FR: INFORMATION IMPORTANTE!

Veillez lire attentivement l'intégralité du manuel avant de commencer à assembler et/ou à utiliser ce produit. Suivez attentivement le manuel et conservez-le pour référence ultérieure.

LV: SVARĪGA INFORMĀCIJA!

Pirms šī izstrādājuma montāžas un/vai lietošanas uzsākšanas pilnībā izlasiet lietošanas pamācību. Stingri ievērojiet pamācības norādījumus un saglabājiet to turpmākai lietošanai.

LT: SVARBI INFORMACIJA!

Prieš pradėdami montuoti gaminį ir (arba) juo naudotis, prašome atidžiai perskaityti visą vadovą. Atidžiai skaitykite vadovą ir turėkite jį su savimi, kad galėtumėte toliau vadovautis jo nuorodomis.

EE: OLULINE TEAVE!

Enne kui alustate toote kokku panemist ja/või kasutamist, lugege see kasutusjuhend hoolikalt läbi. Järgige täpselt juhendis toodud juhiseid ja hoidke juhend alles.

RU: ВАЖНАЯ ИНФОРМАЦИЯ!

Внимательно и полностью прочитайте это руководство, прежде чем приступать к сборке или использованию этого изделия. Следуйте всем инструкциям этого руководства и сохраните его на будущее для справки.

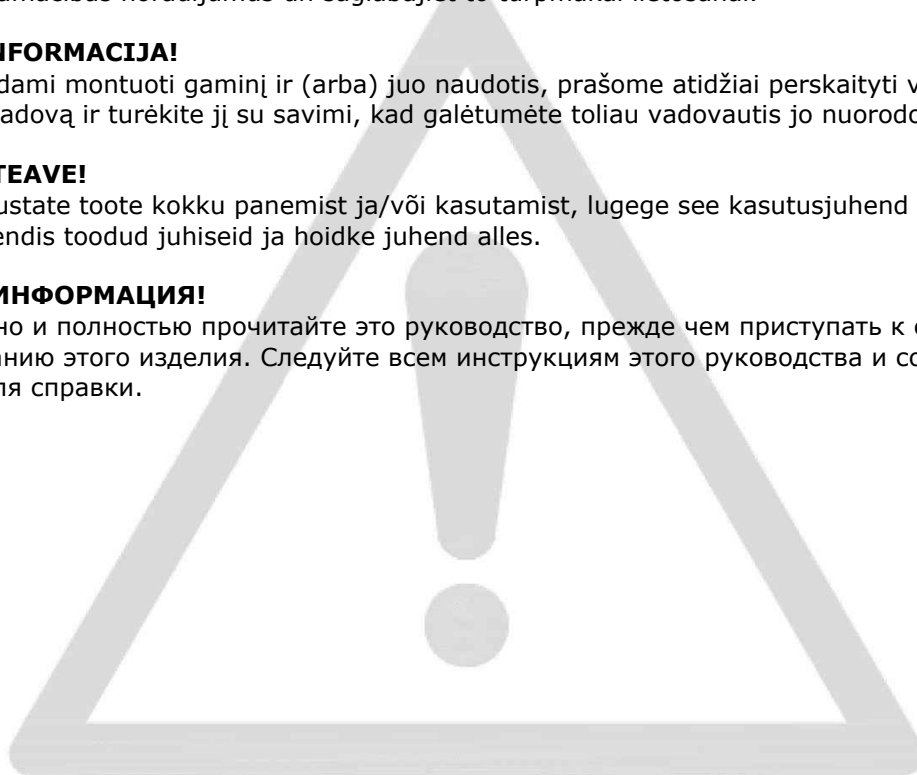

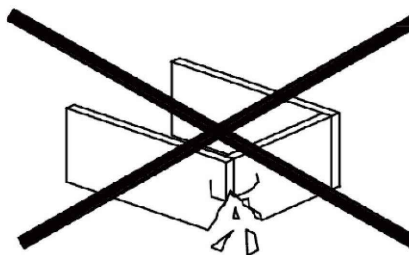
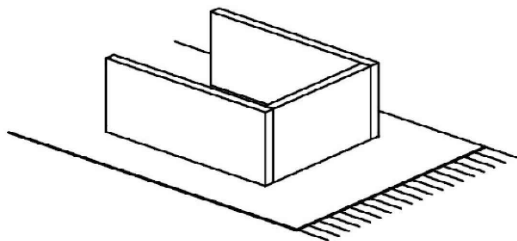

EN: WARNING TO AVOID SCRATCHES!

In order to avoid scratching, this furniture should be assembled on a soft layer - could be a rug.

FR: AVERTISSEMENT POUR ÉVITER LES ÉGRATIGNURES!

Afin d'éviter les égratignures, ce meuble doit être assemblé sur une couche souple - pourrait être un tapis.

LV: BRĪDINĀJUMS PAR SKRĀPĒJUMIEM!

Lai nesaskrāpētu šo izstrādājumu, veiciet montāžu uz mīkstas pamatnes, piemēram, paklāja.

LT: ĮSPĖJIMAS, KAD IŠVENGTUMĖTE ĮBRĖŽIMŲ!

Šio baldų nesubrėžysite, jei jį surinksite ant švelnaus paviršiaus, pavyzdžiui, kilimo.

EE: HOIATUS KRIIMUSTUSTE VÄLTIMISEKS!

Kriimustuste tekkimise vältimiseks mööblile tuleb see kokku panna pehmel pinnal, nt kaltsuvaibal.

RU: ПРЕДУПРЕЖДЕНИЕ ОТНОСИТЕЛЬНО ЦАРАПИН!

Во избежание нанесения царапин, сборку этой мебели необходимо выполнять на мягкой поверхности, например на ковре.

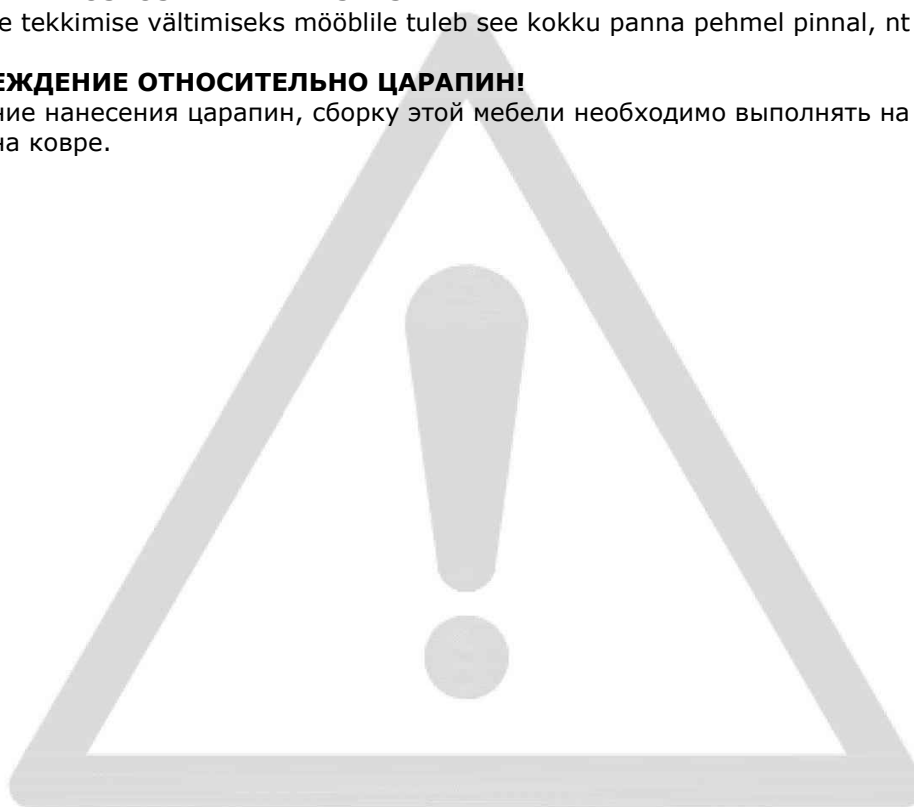

EN: IMPORTANT!

It is important that any product which is assembled using any kind of screw is re-tightened 2 weeks after assembly, and once every 3 months - in order to assure stability through-out the lifespan of the product.

FR: IMPORTANT!

Il est important que tout produit assemblé à l'aide de tout type de vis soit resserré 2 semaines après l'assemblage, et tous les 3 mois, afin d'assurer la stabilité tout au long de la durée de vie du produit.

LV: SVARĪGI!

Ir svarīgi, lai jebkuram produktam, kas tiek uzstādīts ar jebkādu skrūvju palīdzību, skrūves tiktu atkārtoti pievilktas 2 nedēļas pēc montāžas, pēc tam – reizi 3 mēnešos, tā nodrošinot stabilitāti visā izstrādājuma kalpošanas laikā.

LT: SVARBU!

Bet kokį varžtais tvirtinamą gaminį 2 savaites po surinkimo bei kas 3 mėnesius reikia papildomai suveržti – taip užtikrinamas naudojamo gaminio stabilumas.

EE: TÄHTIS!

Oluline on, et toote kruvisid pingutataks 2 nädalat pärast kokkupanekut ja seejärel iga 3 kuu järel, et tagada stabiilsus kogu toote eluea jooksul.

RU: ВАЖНО!

В любом изделии, собранном с использованием винтов любого типа, необходимо через 2 недели после сборки и в дальнейшем каждые 3 месяца подтягивать винты, чтобы обеспечить прочность изделия в течение срока эксплуатации.





EN: GENERAL INSTRUCTION FOR FURNITURE SURFACES!

*Wipe clean with a damp cloth. Use only water or a gentle detergent.
Wipe dry with a clean cloth.*

FR: INSTRUCTIONS GÉNÉRALES POUR LE MOBILIER

*Nettoyer à l'aide d'un chiffon humide. Utiliser uniquement de l'eau ou un détergent doux.
Essuyer à l'aide d'un chiffon propre.*

LV: VISPĀRĪGI KOPŠANAS NORĀDĪJUMI MĒBEĻU VIRSMĀM!

*Noslaukiet ar mitru drānu. Lietojiet tikai ūdeni vai maigu mazgāšanas līdzekli.
Nosusiniet ar tīru drānu.*

LT: BENDRIEJI NURODYMAI DĖL BALDŲ PAVIRŠIŲ!

*Valykite drėgnu skudurėliu. Naudokite tik vandenį arba švelnų valiklį.
Nusausinkite švarių skudurėliu.*

EE: ÜLDISED JUHISED MÖÖBLIPINDADE JAOKS!

*Kasutage puhastamiseks niisket lappi. Kasutage ainult vett või õrnatoimelist puhastusvahendit.
Pühkige puhta lapiga kuivaks.*

RU: ОБЩИЕ ПРАВИЛА ЭКСПЛУАТАЦИИ МЕБЕЛЬНЫХ ПОВЕРХНОСТЕЙ!

*Очистите изделие чистой влажной тканью. Используйте мягкодействующее моющее средство.
Вытрите досуха чистой тряпкой.*

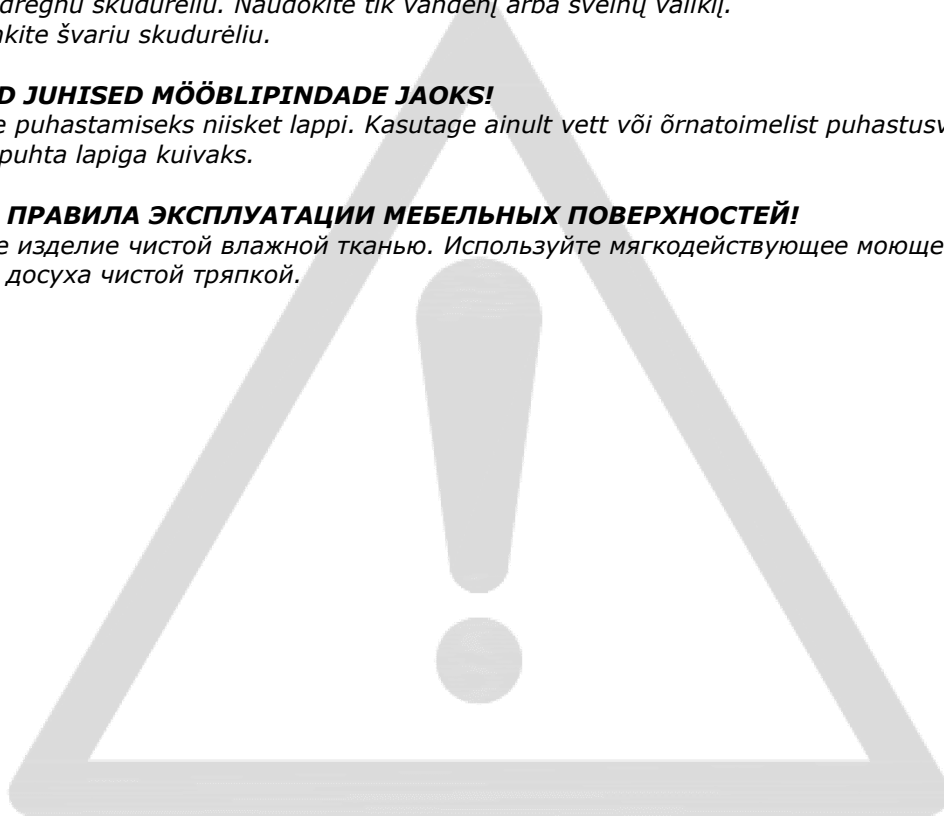

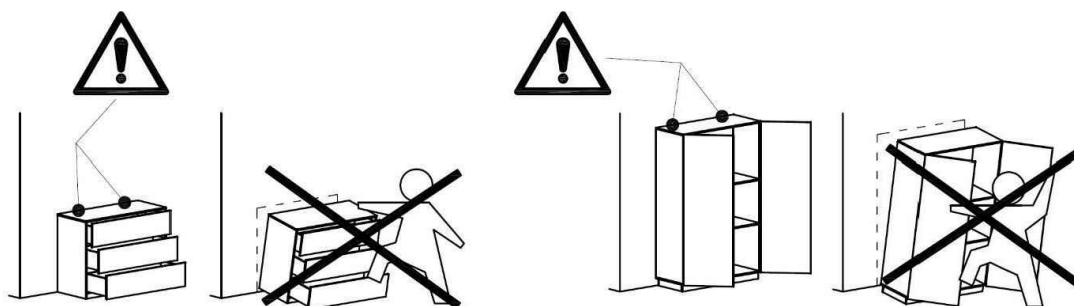

EN: ANTI-TOPPLE WARNING!

In order to prevent a possible fatal injury this product must be permanently fixed to the wall with the brackets included. The screws included are not to be used for fastening the the product to the wall. Please contact your DIY or hardware store for advice on the correct type of screws/raw plugs to use for your type of wall.

FR: AVERTISSEMENT ANTIBASCULEMENT!

Ce produit doit être fixé de manière permanente au mur à l'aide du/des support(s) inclus afin d'éviter des blessures mortelles en cas de basculement. L'emballage contient des vis pour attacher le(s) support(s) antibasculement au produit. Veuillez contacter votre magasin de bricolage ou votre quincaillerie pour obtenir des conseils sur le type de vis/chevilles adapté à votre mur.

LV: BRĪDINĀJUMS PAR APGĀŠANOS!

Šis produkts ir jāpiestiprina pie sienas ar komplektā iekļauto(-ajiem) kronšteinu(-iem), lai novērstu nāvējošu savainojumu risku, tam apgāžoties. Iepakojuma ir skrūves tikai pretapgāšanās kronšteina(-u) piestiprināšanai pie produkta. Informāciju par to, kādas skrūves piemērotas Jūsu sienai, jautājiet saimniecības preču vai būvizstrādājumu veikalā.

LT: ĮSPĖJIMAS DĖL NUVERTIMO!

Šį gaminį būtina tinkamai pritvirtinti prie sienos naudojant pridėtas gembes, kad išvengtumėte mirtino sužalojimo jam nuvirtus. Pakuotėje yra tik varžtai gembėms prie gaminio pritvirtinti. Užeikite į artimiausią statybinių prekių parduotuvę ir paprašykite savo sienai tinkamiausių varžtų (kaiščių).

EE: ÜMBERKUKKUMISOHT!

Toote ümberkukkumisest tuleneda võiva eluohtrliku õnnetuse vältimiseks tuleb see kinnitada komplekti kuuluva(te) kronsteini(de) abil püsivalt seina külge. Komplekti kuuluvad ainult kruvid, mis on mõeldud ümberkukkumist takistava(te) kronsteini(de) kinnitamiseks toote külge. Soovituste saamiseks sobivate kruvide/tüüblite leidmiseks oma seina jaoks, konsulteerige DIY esindaja või rauakaupade kaupluse müüjaga.

RU: ПРЕДУПРЕЖДЕНИЕ ОБ ОПРОКИДЫВАНИИ!

Во избежание опрокидывания это изделие должно быть надежно прикреплено к стене с помощью прилагаемых кронштейнов. В комплект входят винты только для прикрепления кронштейнов к самому изделию. Шурупы и дюбели для крепления к стене конкретного типа можно найти в строительном или хозяйственном магазине.



EN: IMPORTANT!

Mounting screws are not included.

Always make sure that the fastening method you choose is suitable and safe for your home.

FR: IMPORTANT

Les vis de montage ne sont pas fournies.

Assurez-vous toujours que la méthode de montage que vous choisirez convienne à votre domicile et soit sûre.

LV: SVARĪGI!

Montāžas skrūves nav iekļautas komplektācijā.

Vienmēr pārliecinieties, ka jūsu izvēlētajā stiprināšanas metode ir piemērota un droša jūsu mājoklim.

LT: SVARBU!

Tvirtinimo varžtai prie gaminio nėra pridėti.

Pagalvokite, ar pasirinktas tvirtinimo būdas yra tinkamas Jūsų namams ir yra saugus.

EE: TÄHTIS!

Kinnituskruvid ei kuulu komplekti.

Alati veenduge, et teie valitud kinnitusmeetod on teie kodu jaoks sobiv ja ohutu.

RU: ВАЖНО!

Крепежные шурупы не входят в комплект.

Обязательно убедитесь, что выбранный способ крепления является допустимым и безопасным для вашего дома.

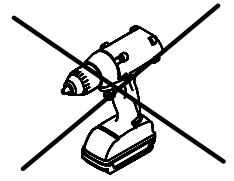
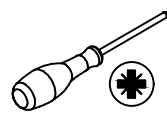
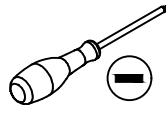
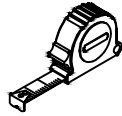
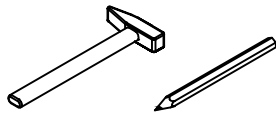

A x4



M4.5x60mm

B x8



M4x30

C x16

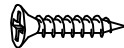

M3x16mm

D x3



M4x24mm

E x20



Ø8x30mm

F x20

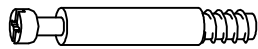

M6x30mm

G x20

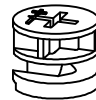

Ø15x12mm

H x3

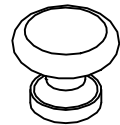

K x1

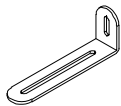

72X15X25mm

M x2



Ø14x1.2mm

N x1



M4x14mm

J x2

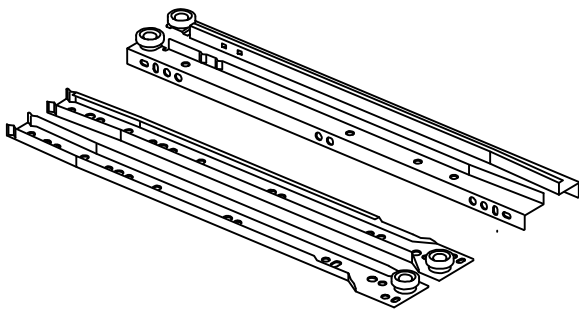

L=350mm

L x1

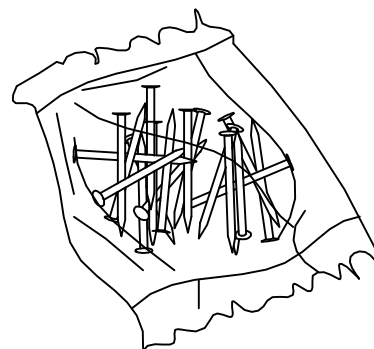

Ø1.2X18mm

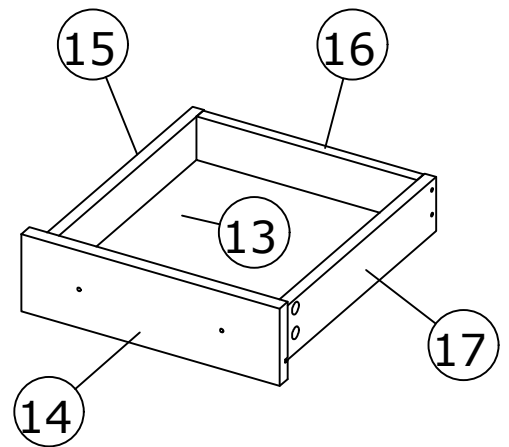
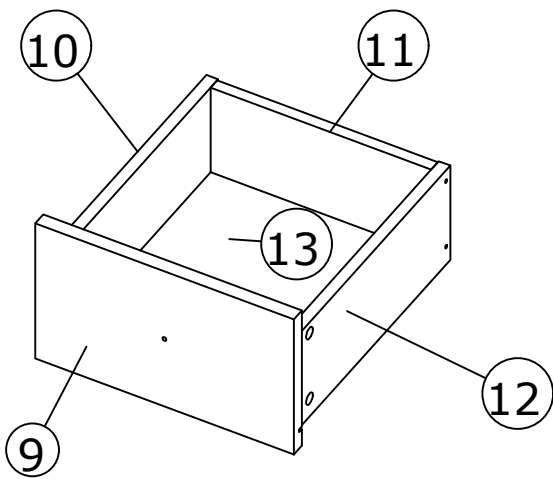
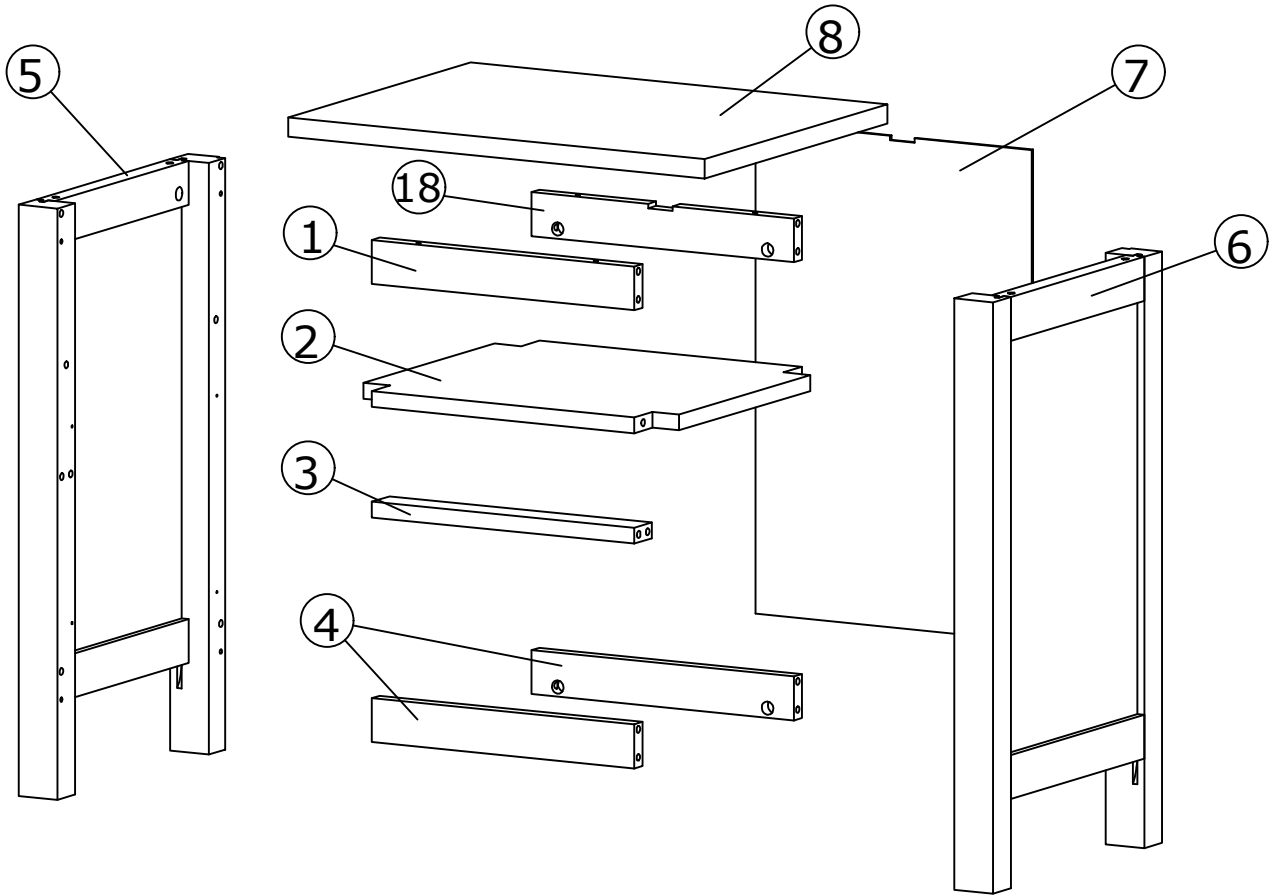

Box: 1/1



① x1
50*340*18

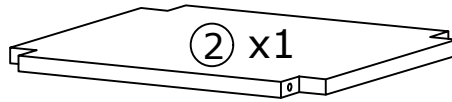

② x1
398*368*18

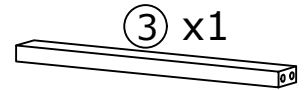

③ x1
40*340*18

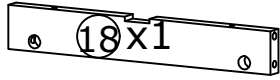

④ x1
50*340*18

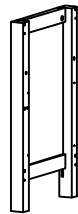

⑤ x1

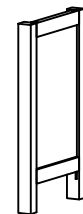

⑥ x1

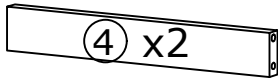

④ x2
50*340*18

⑤ x1
372*674*45

⑥ x1
372*674*45

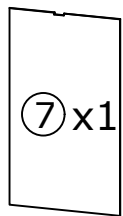

⑦ x1
358*560*3

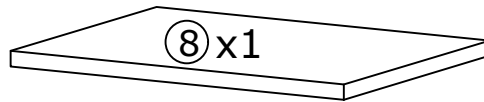

⑧ x1
540*410*22

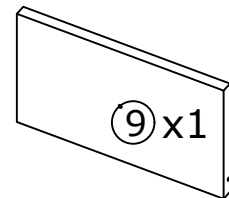

⑨ x1
335*198*15

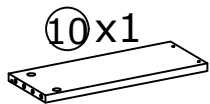

⑩ x1
138*350*15

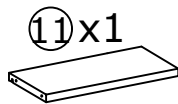

⑪ x1
138*284*15

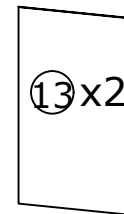

⑬ x2
299*350*3

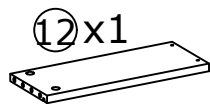

⑫ x1
138*350*15

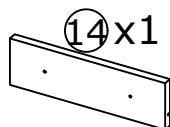

⑭ x1
335*100*15



⑰ x1
70*350*15

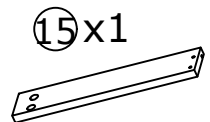

⑮ x1
70*350*15

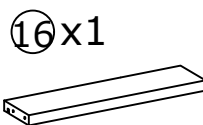

⑯ x1
70*284*15

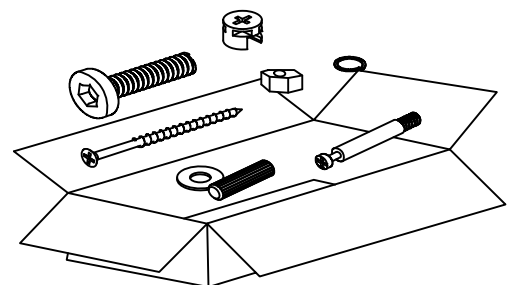

1

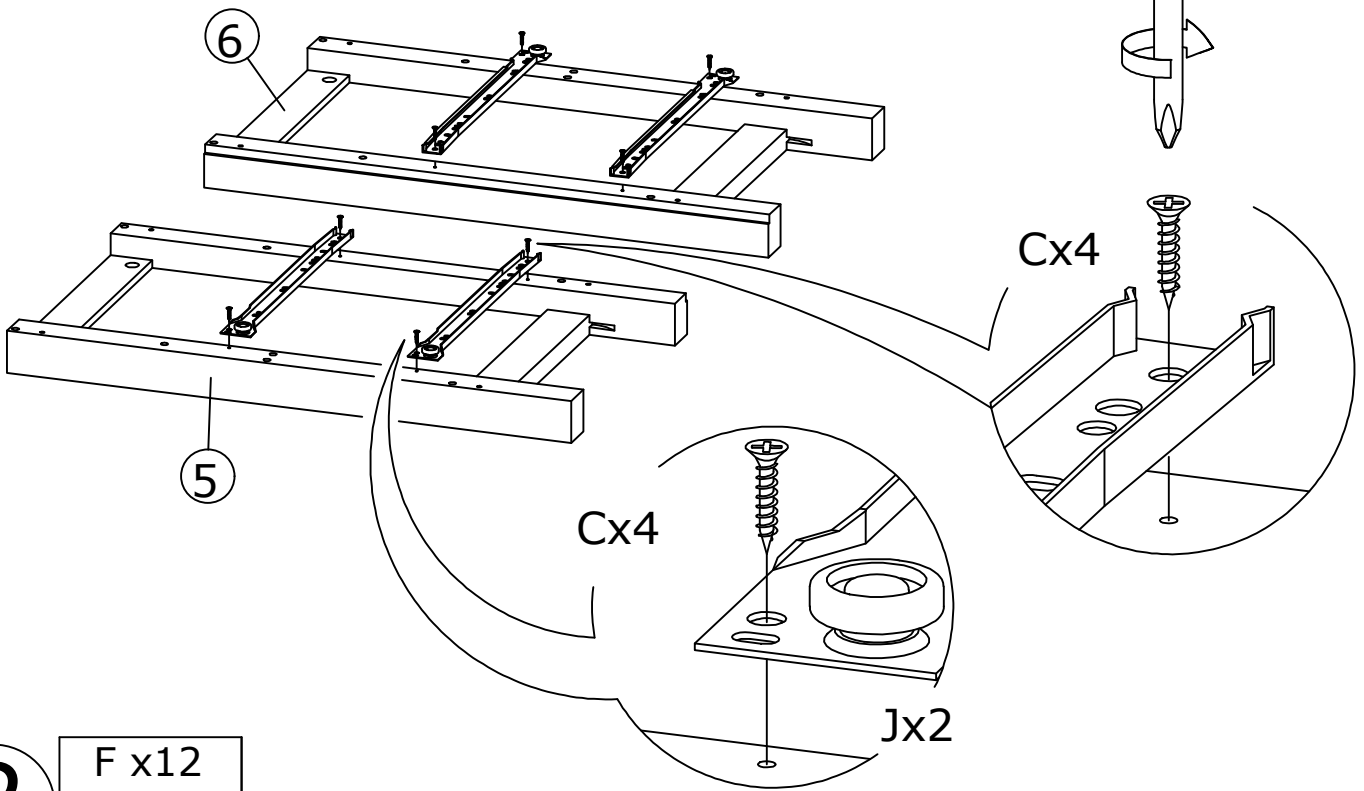
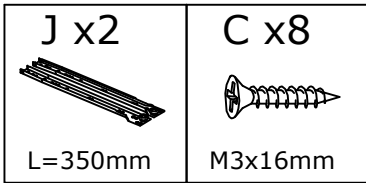

2

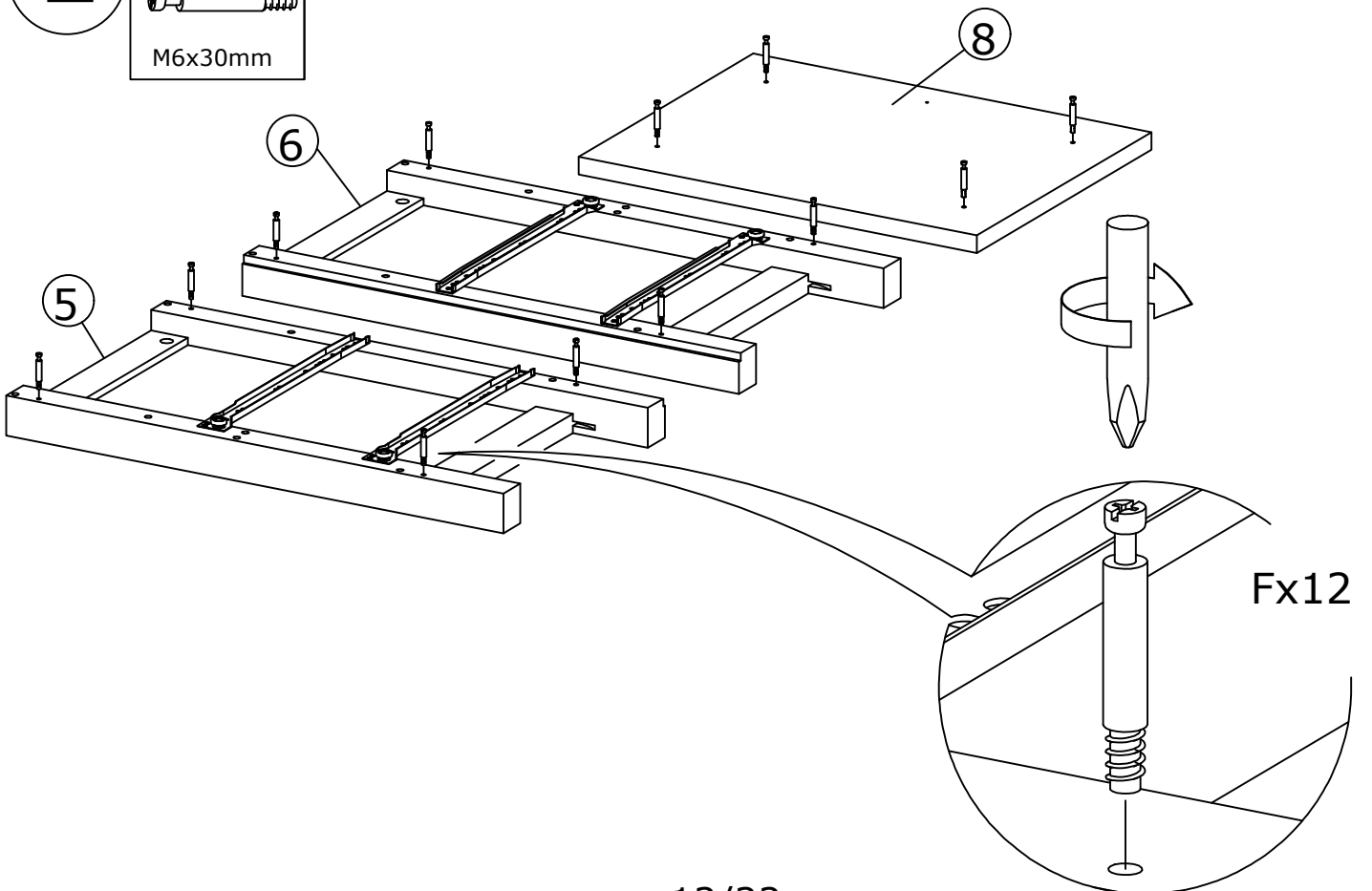
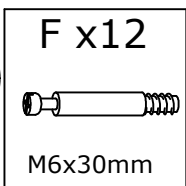

3

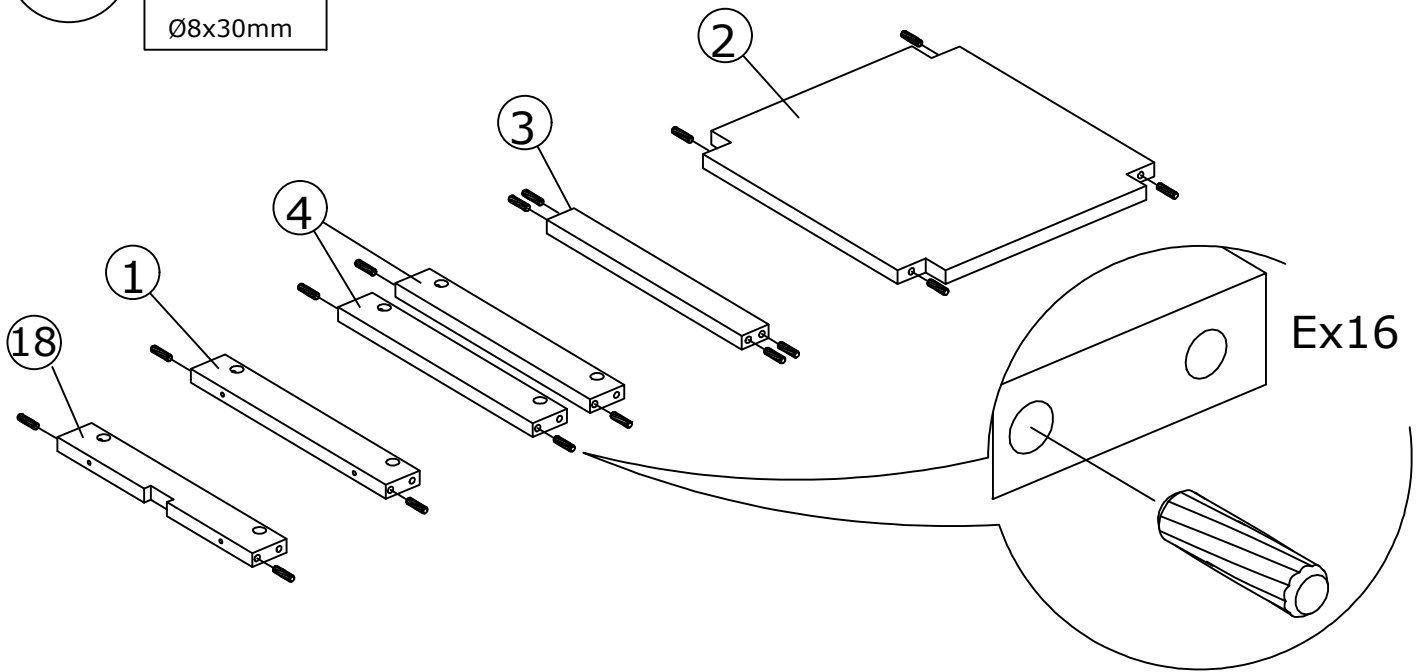
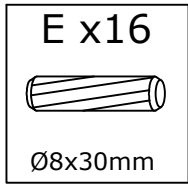

4

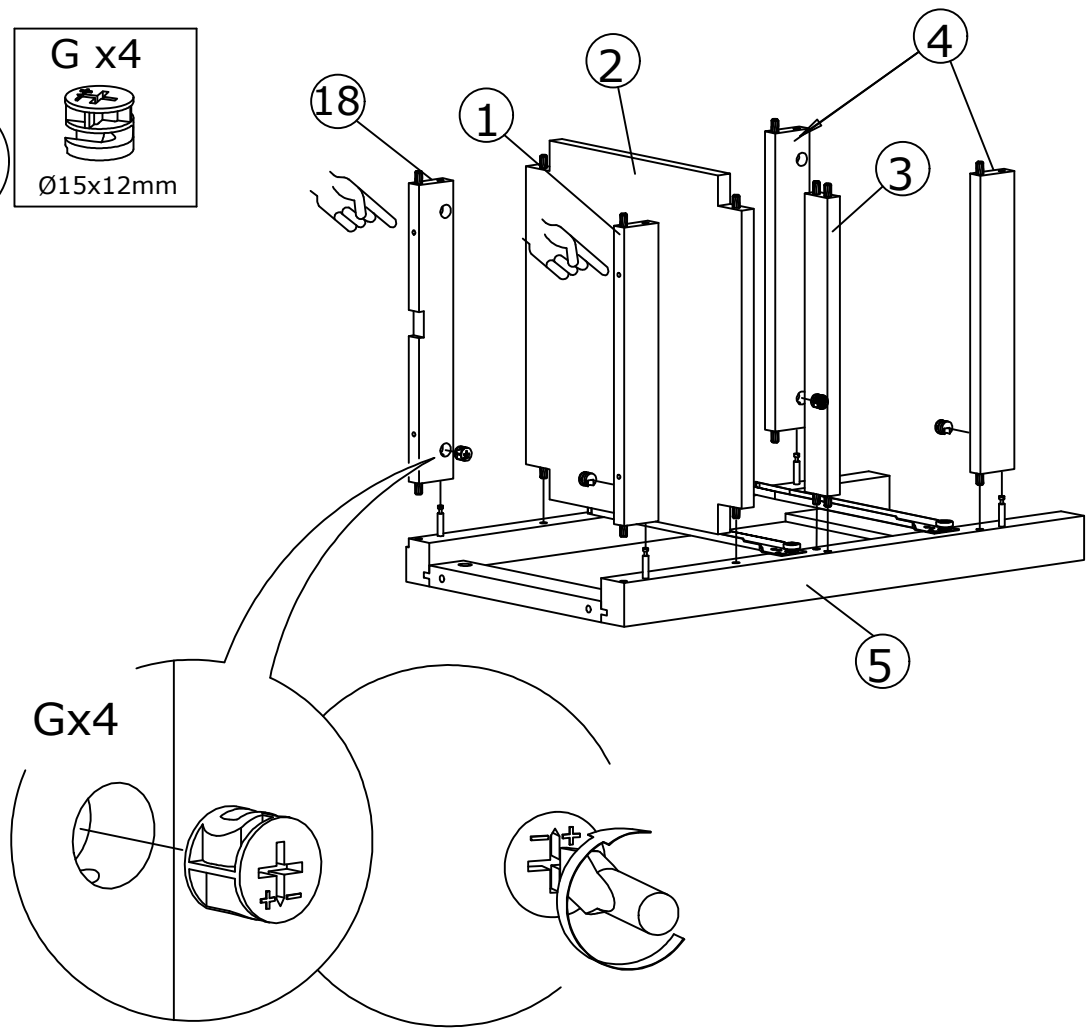
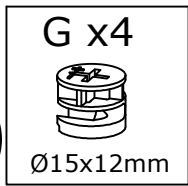

5

G x4
Ø15x12mm

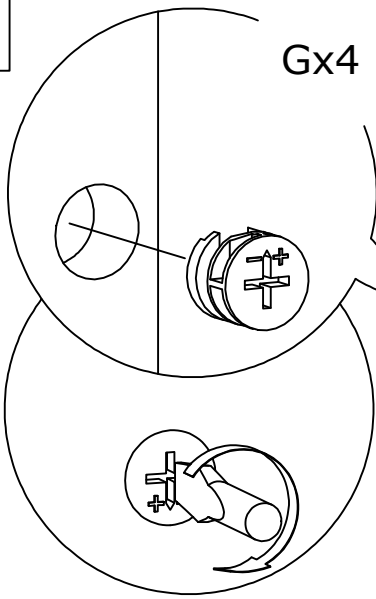

Gx4

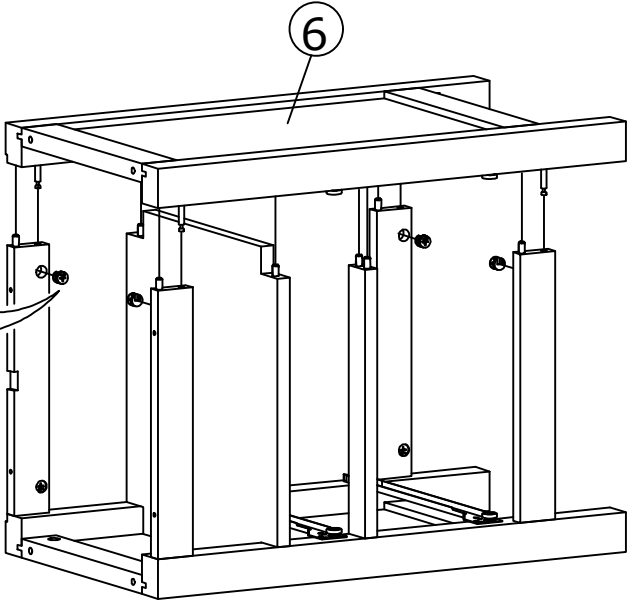

6

A x4
M4.5x60mm

G x4
Ø15x12mm

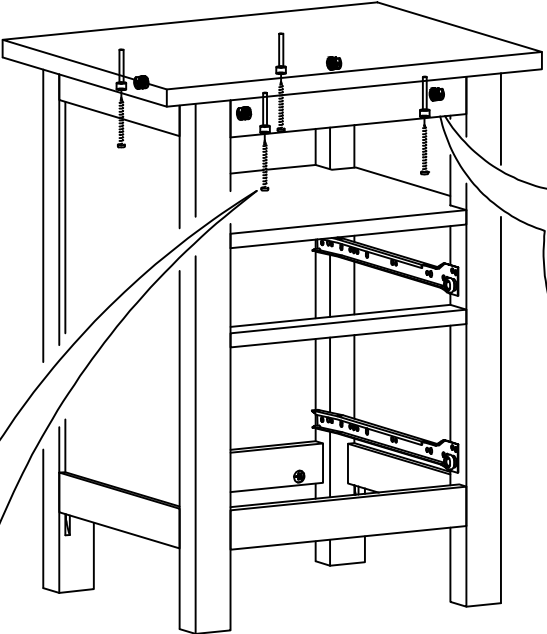
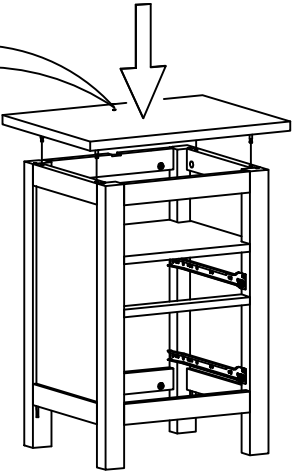
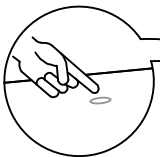

Gx4

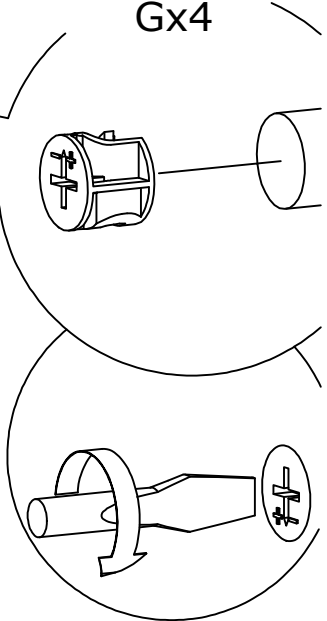

Ax4

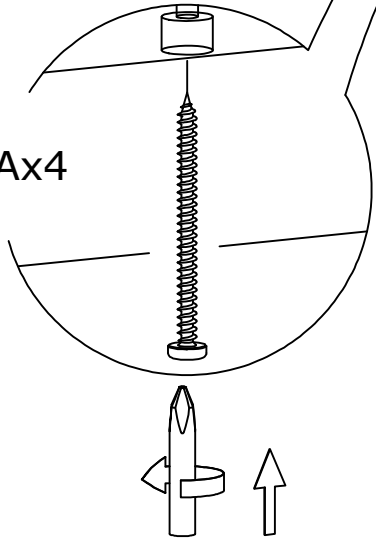

7

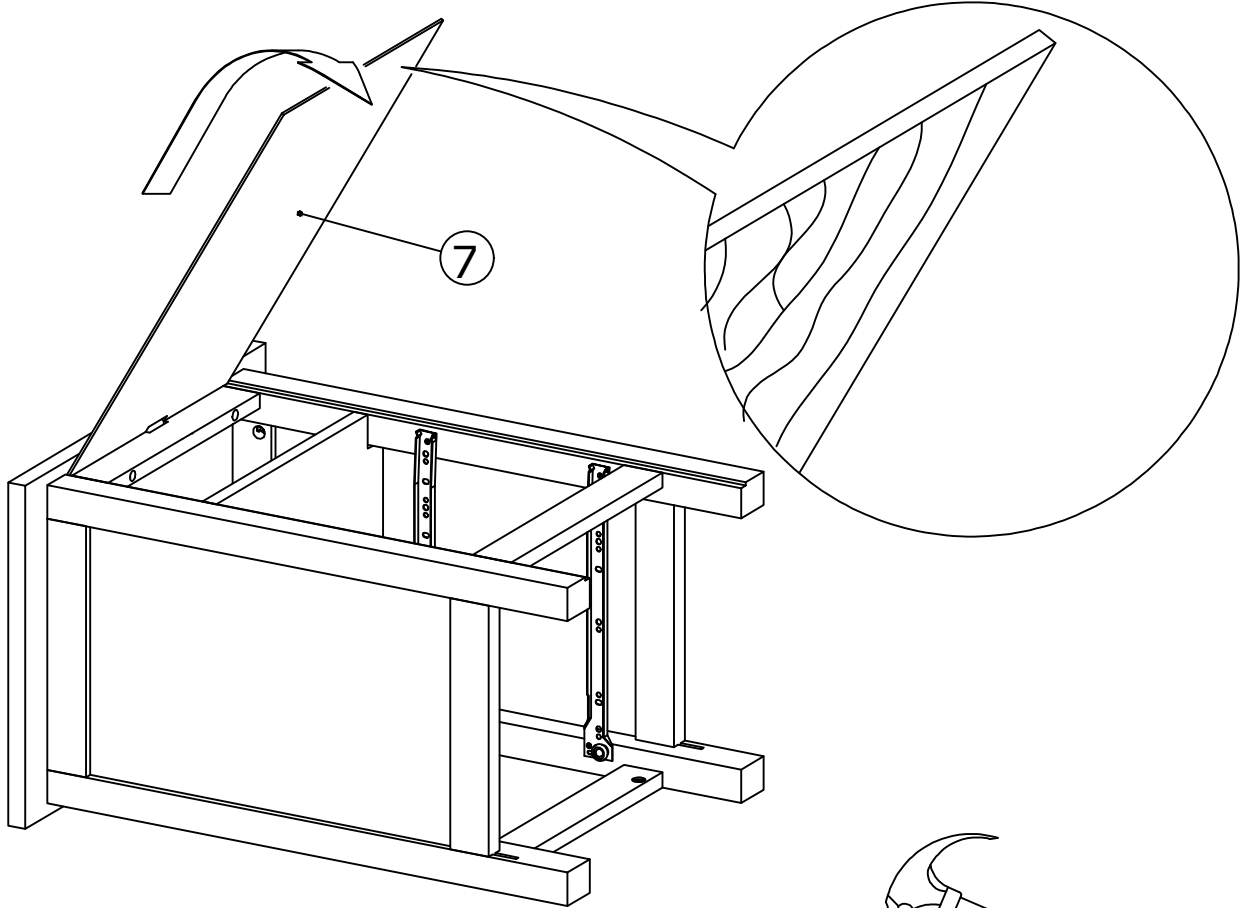

8

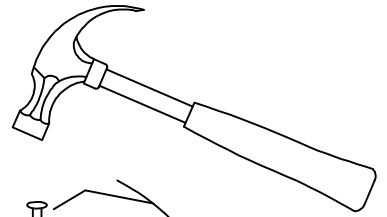

L x 1

Ø1.2X18mm

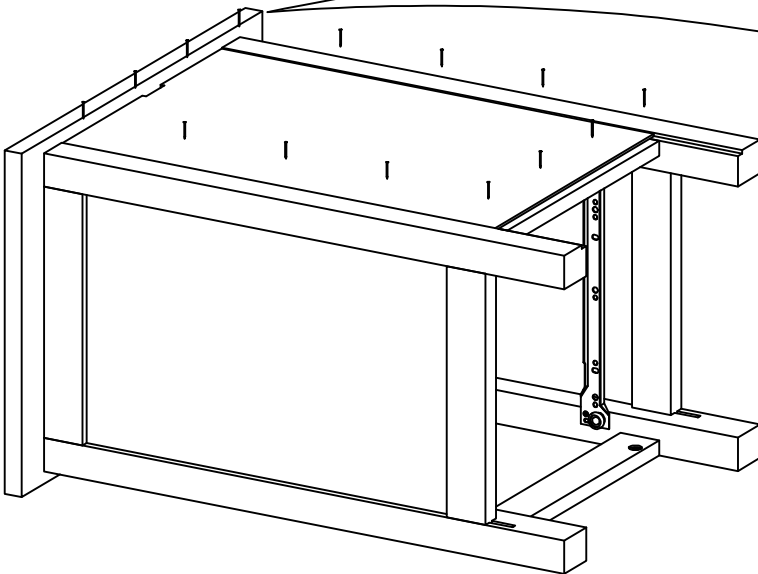
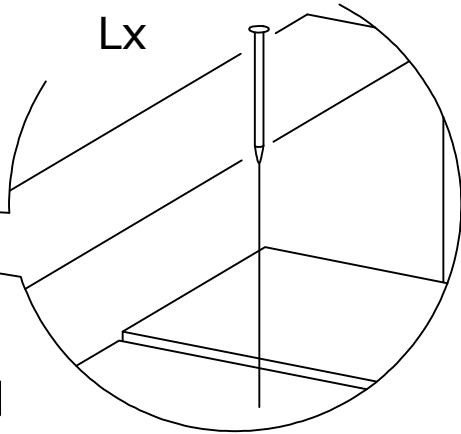

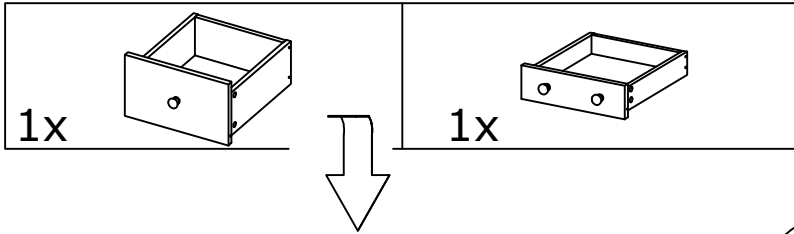
Lx

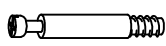



E x4  Ø8x30mm	F x4  M6x30mm	G x4  Ø15x12mm
--	---	--

9

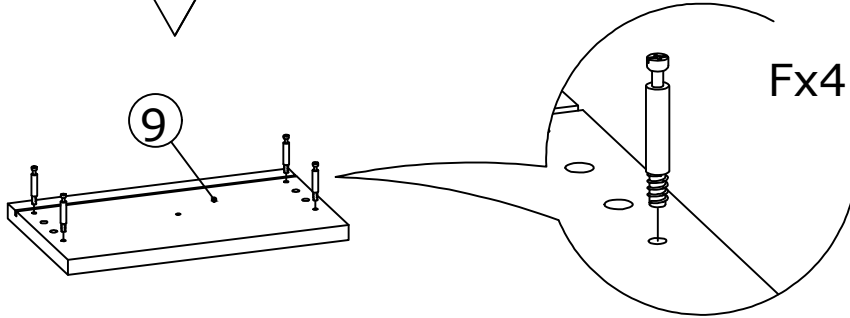

10

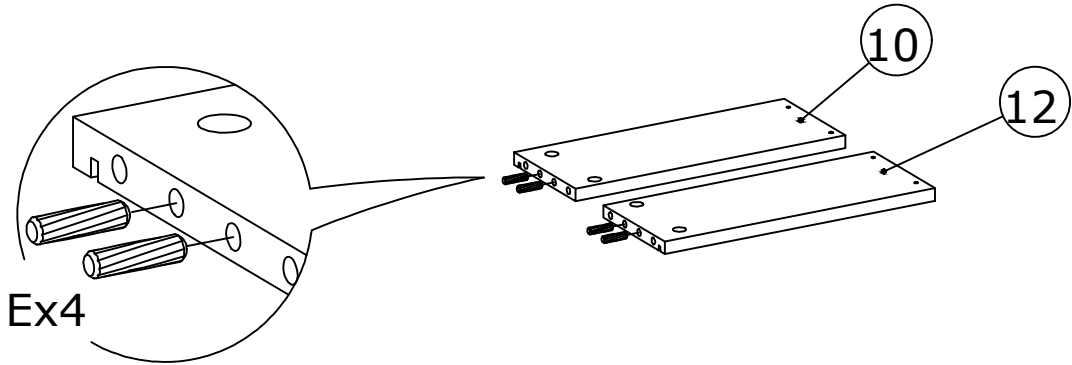

11

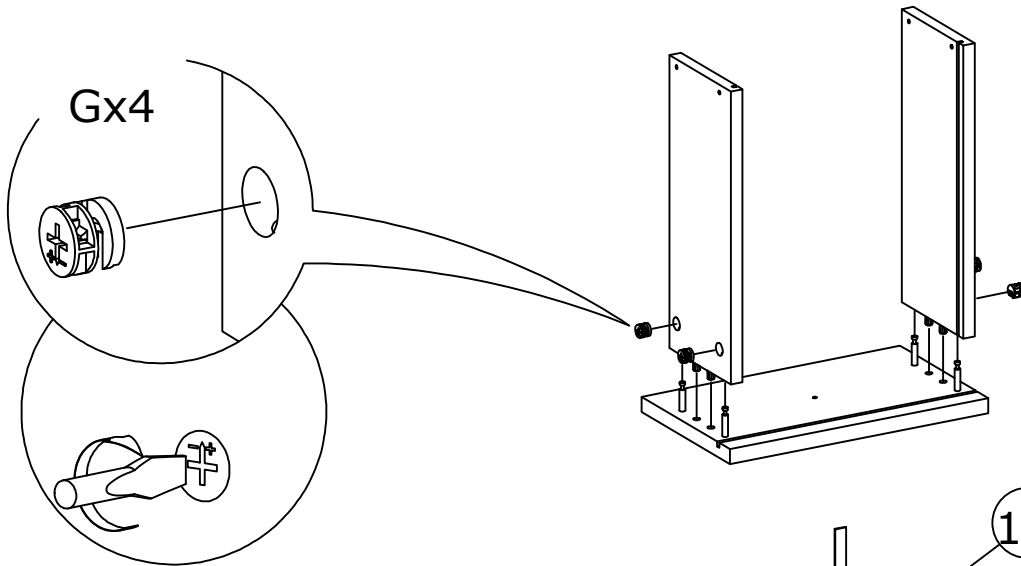

12

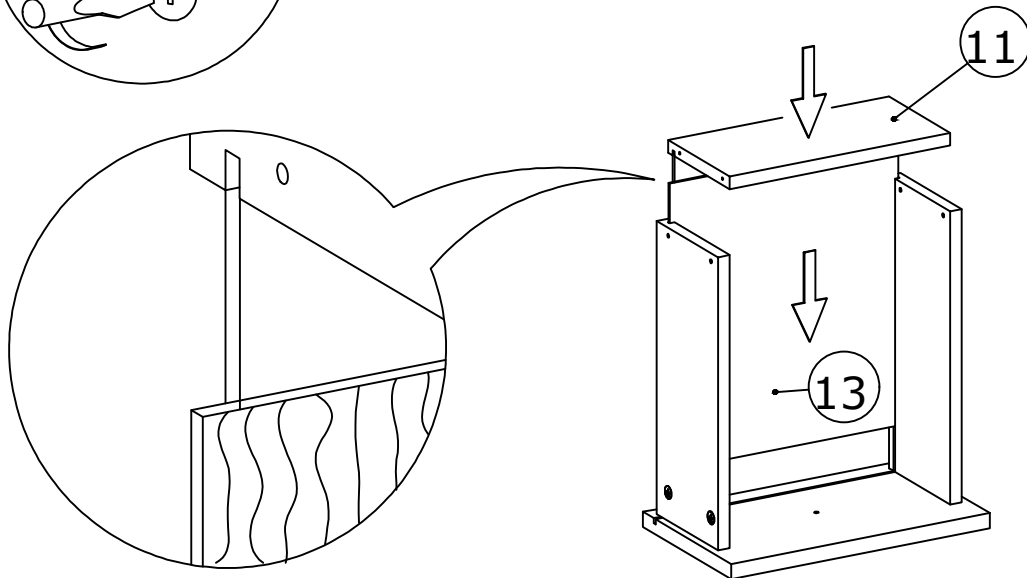

13

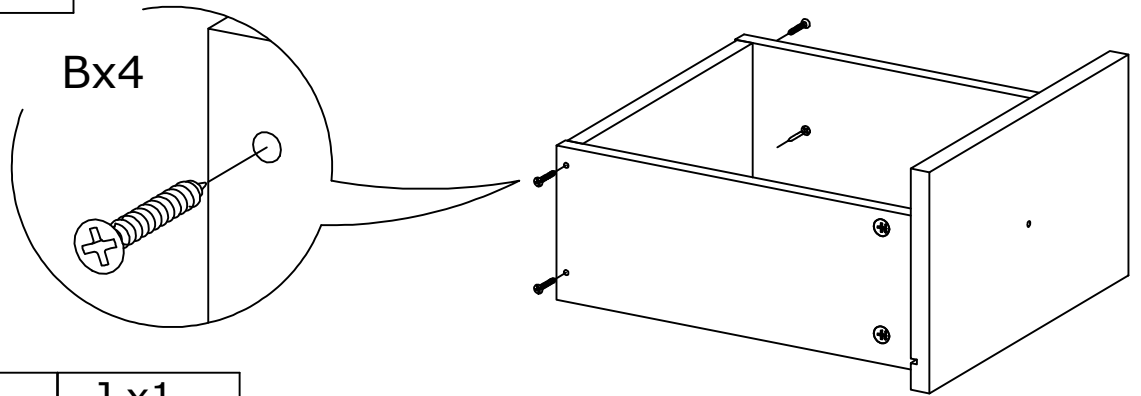
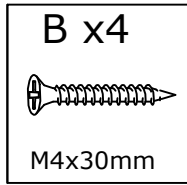



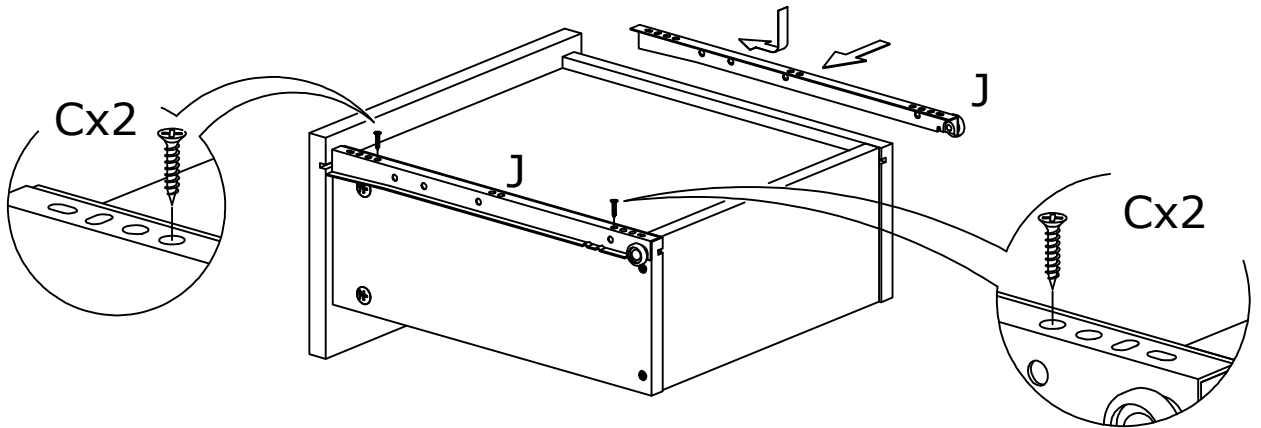
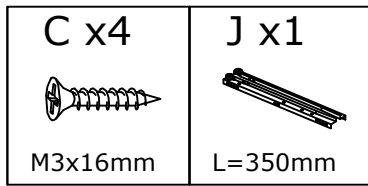

14

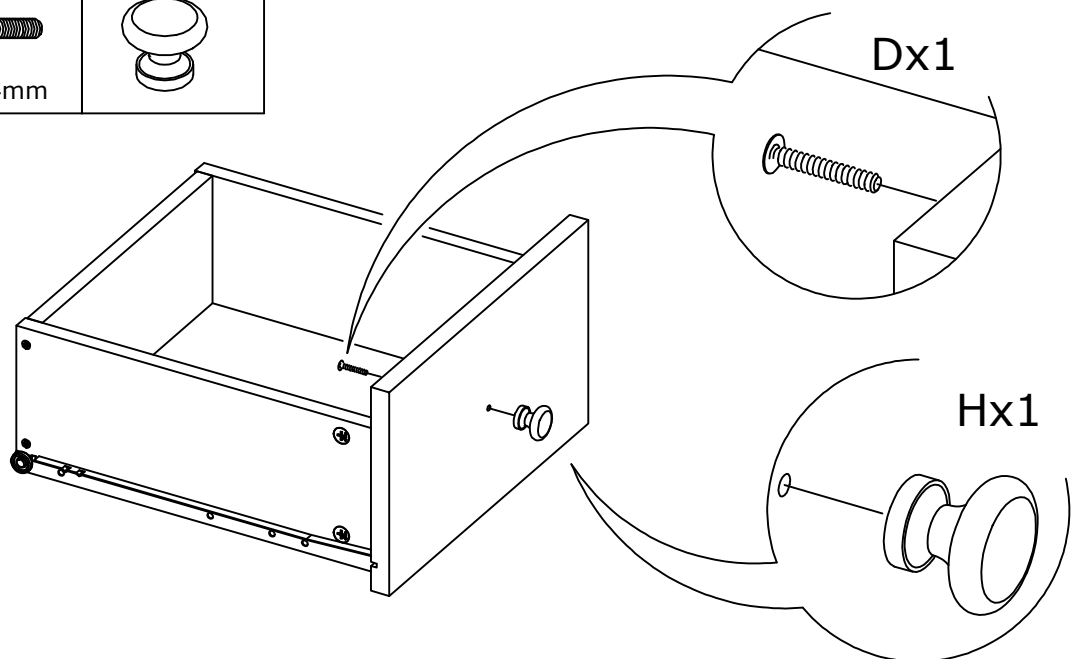
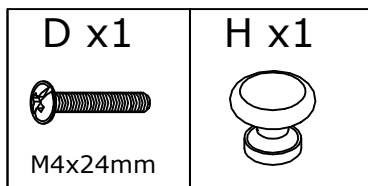

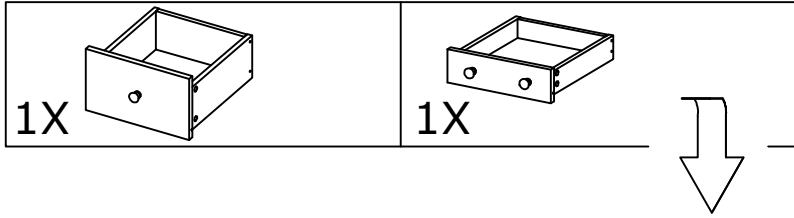
15



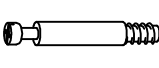

B x4  M4x30mm	F x4  M6x30mm	G x4  Ø15x12mm
--	---	--

16

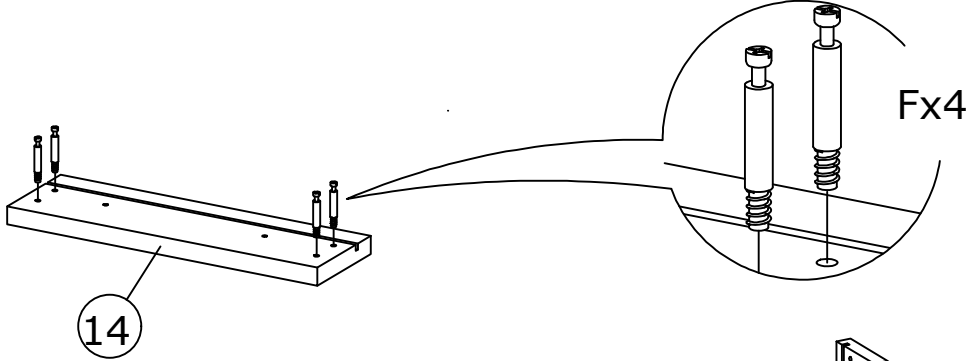

17

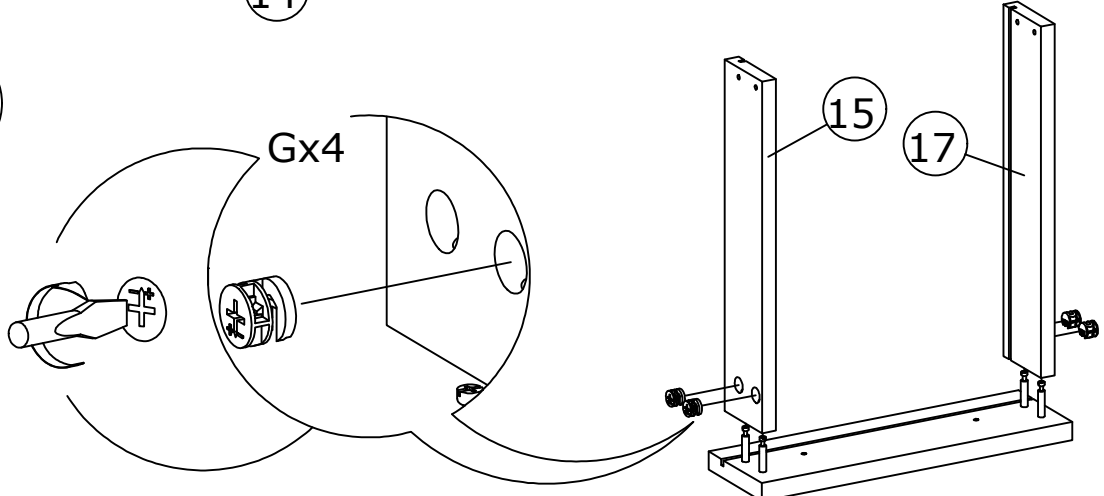

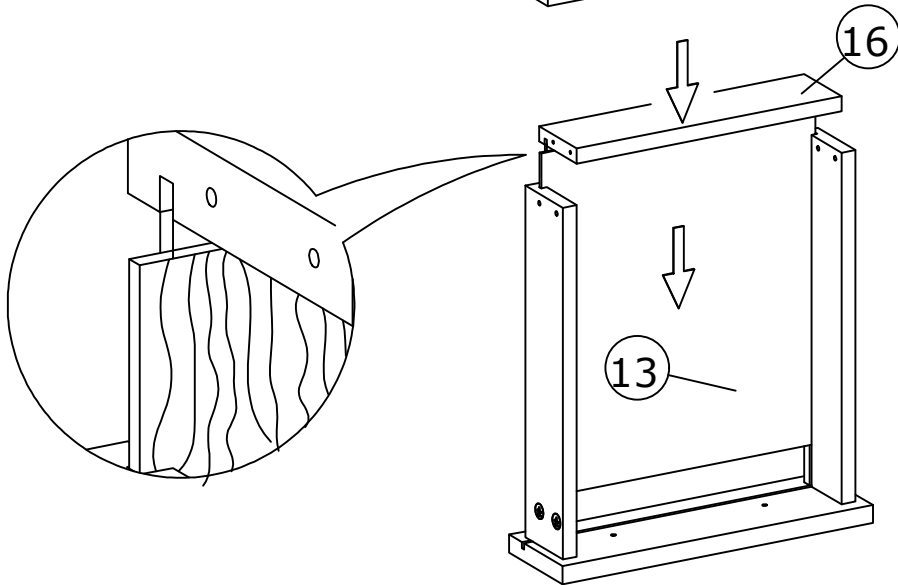

18

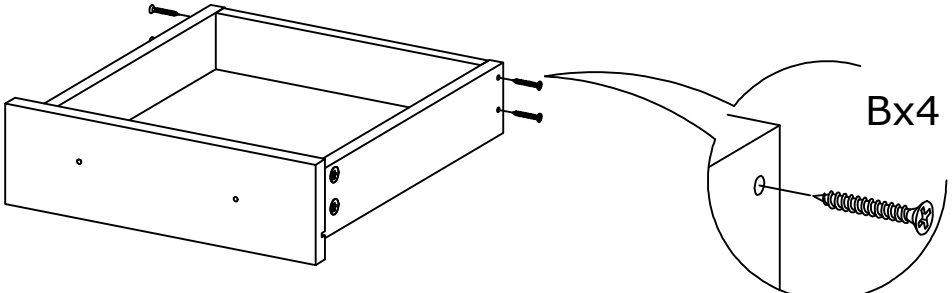

19



20

C x4  M3x16mm	J x1  L=350mm
--	--

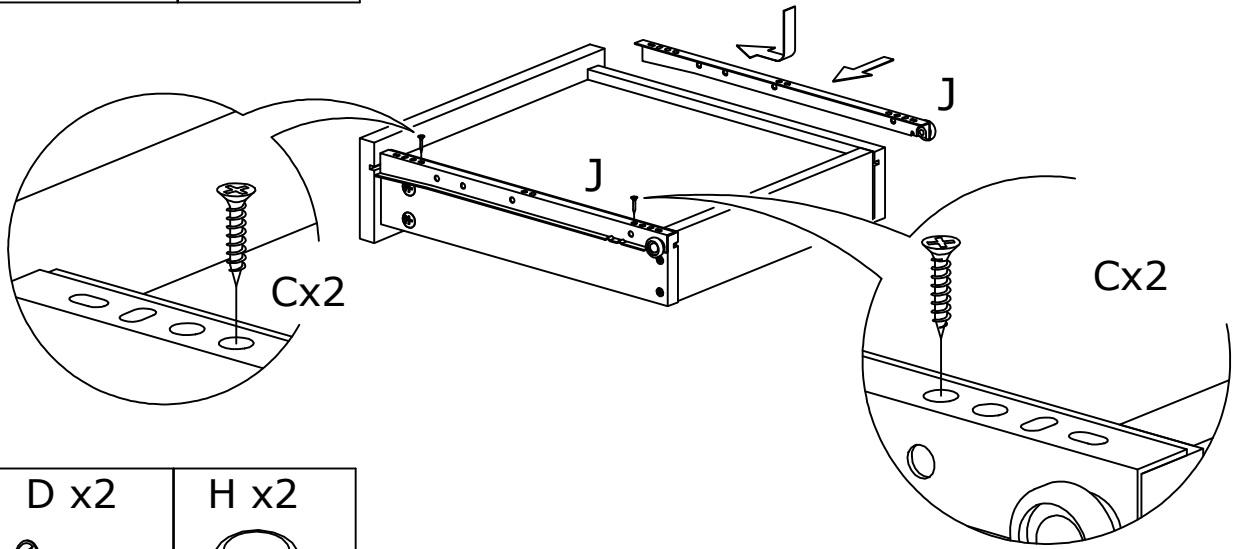

21

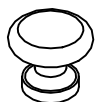
D x2  M4x24mm	H x2 
--	---

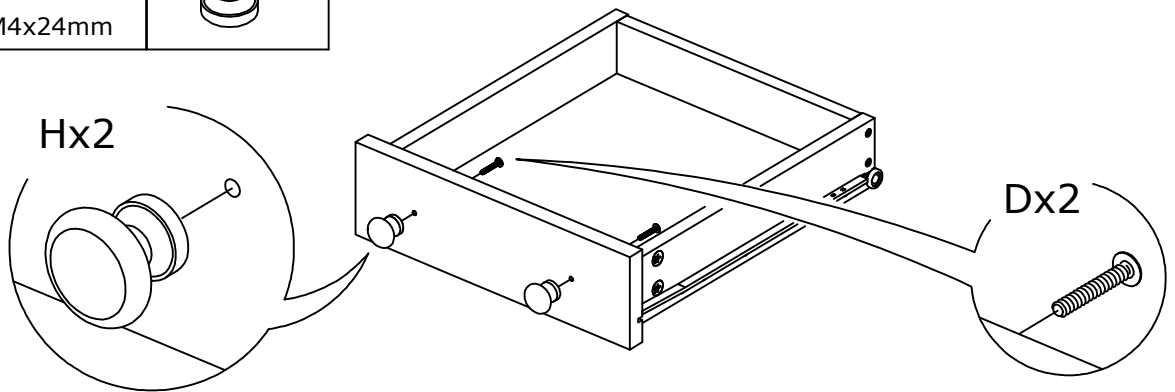

22

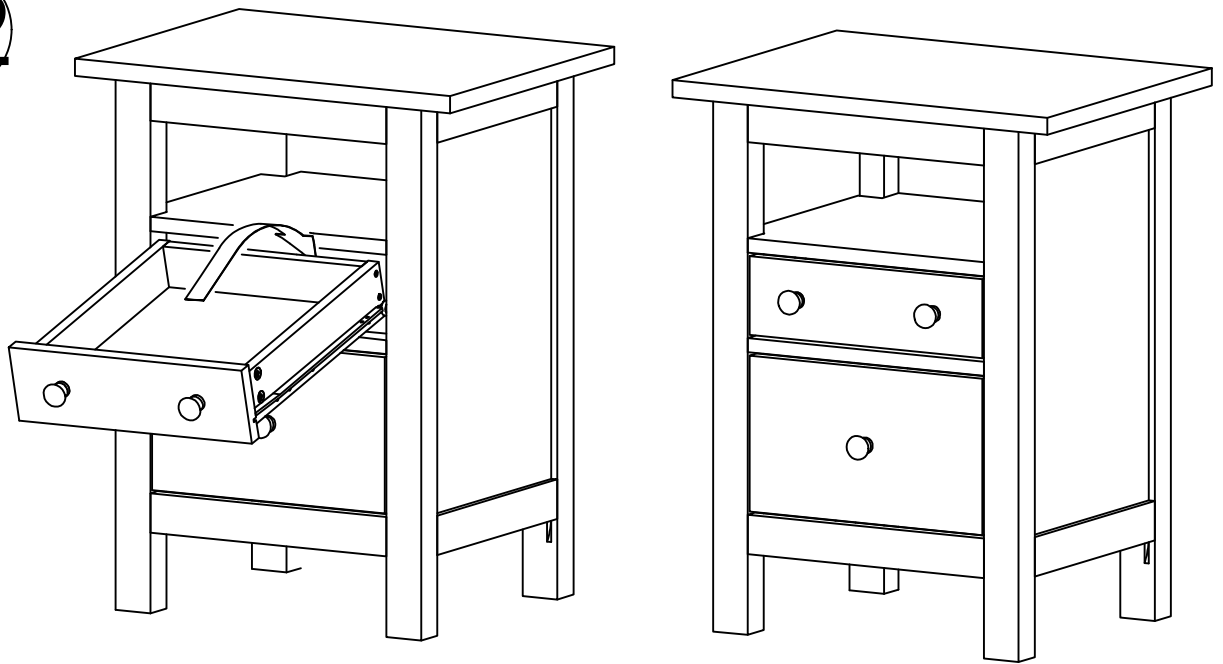

23

Kx1
72X15X25mm

Mx1
Ø14x1.2mm

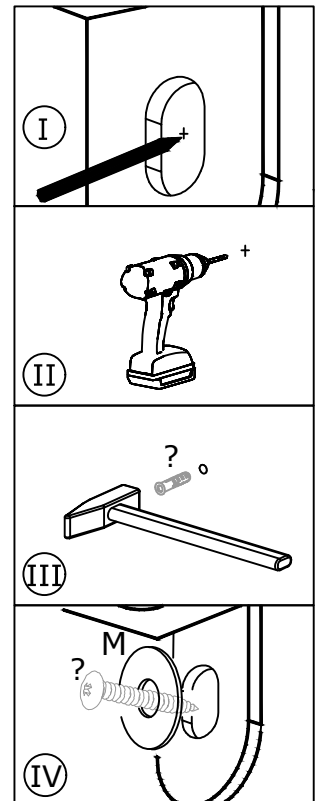
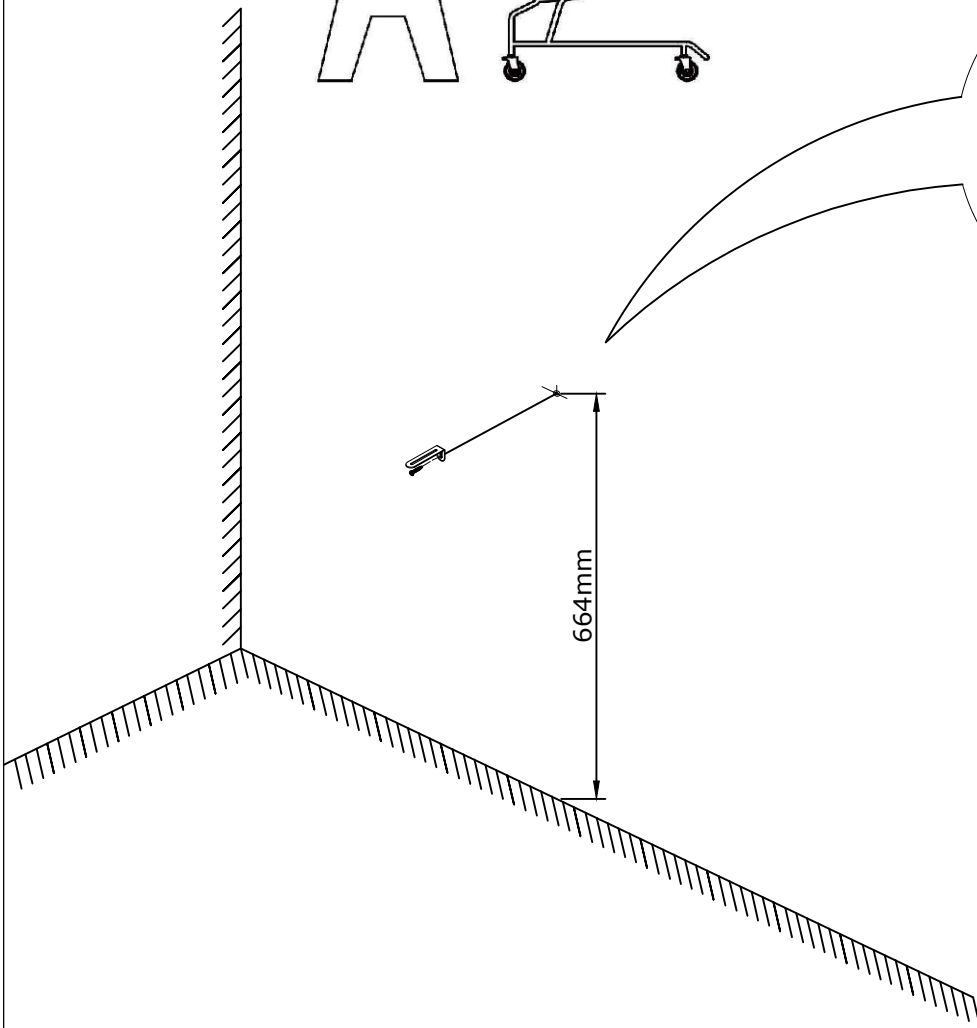
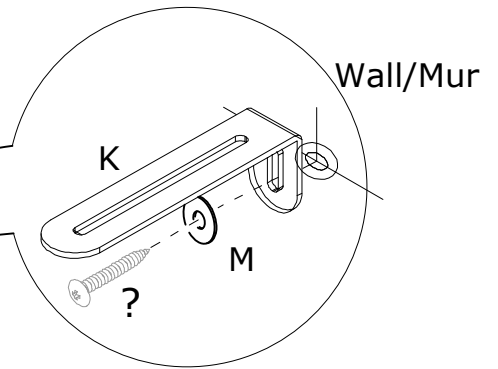
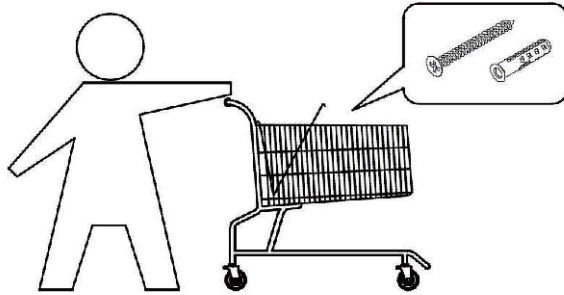
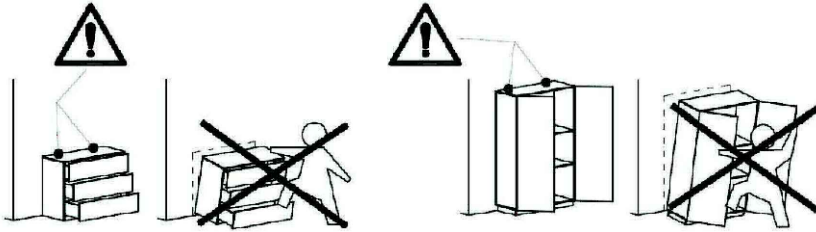
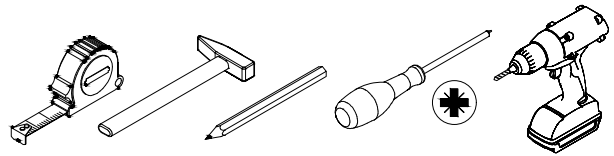

24

<p>Nx1  M4x14mm</p>	<p>Mx1  Ø14x1.2mm</p>	
--	--	---

