

VERMELEV

137518/726-256-1250
139657/726-266-1011
139686/726-266-1032

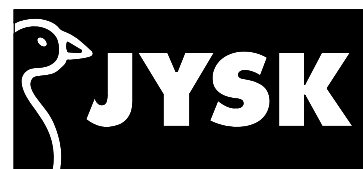

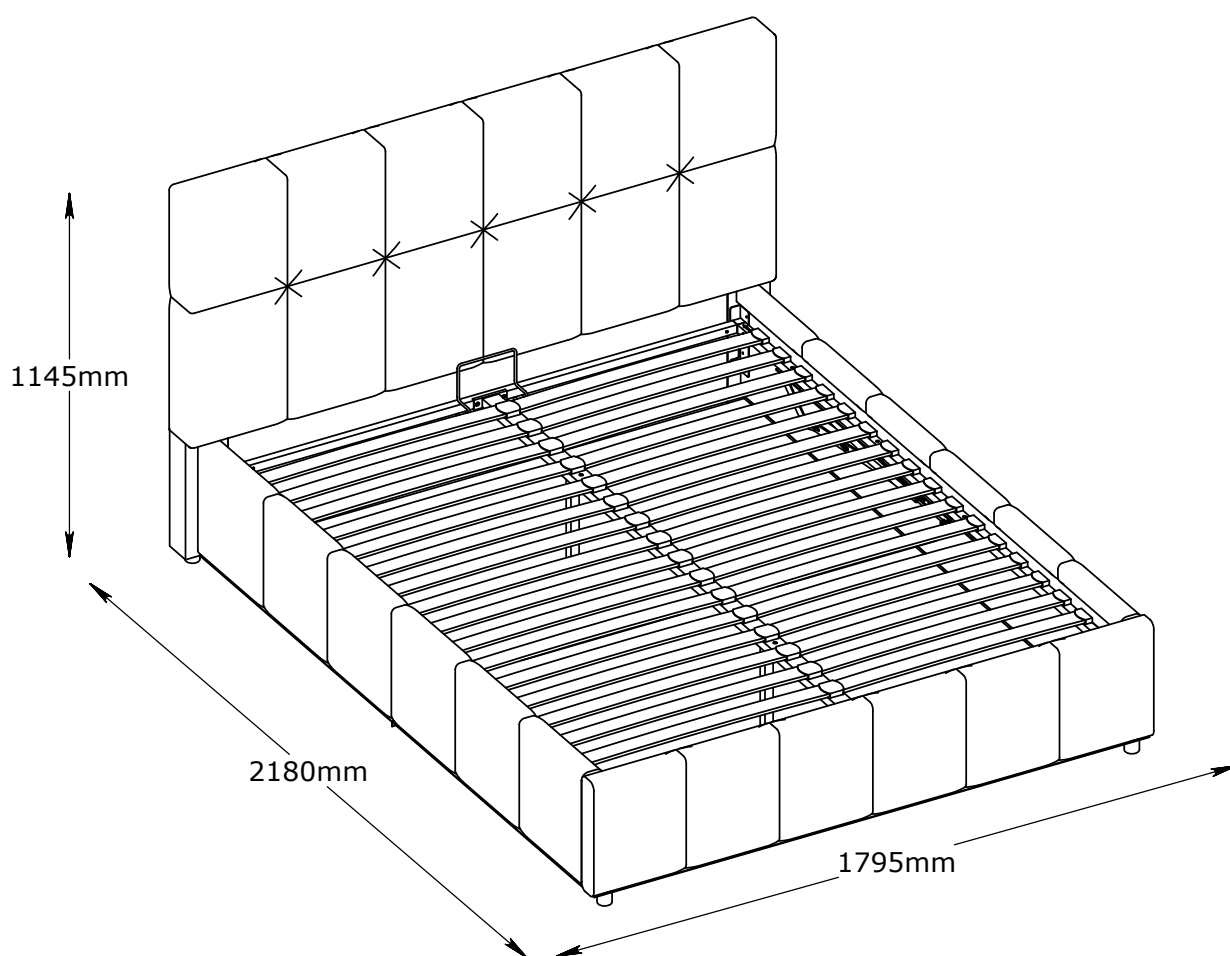

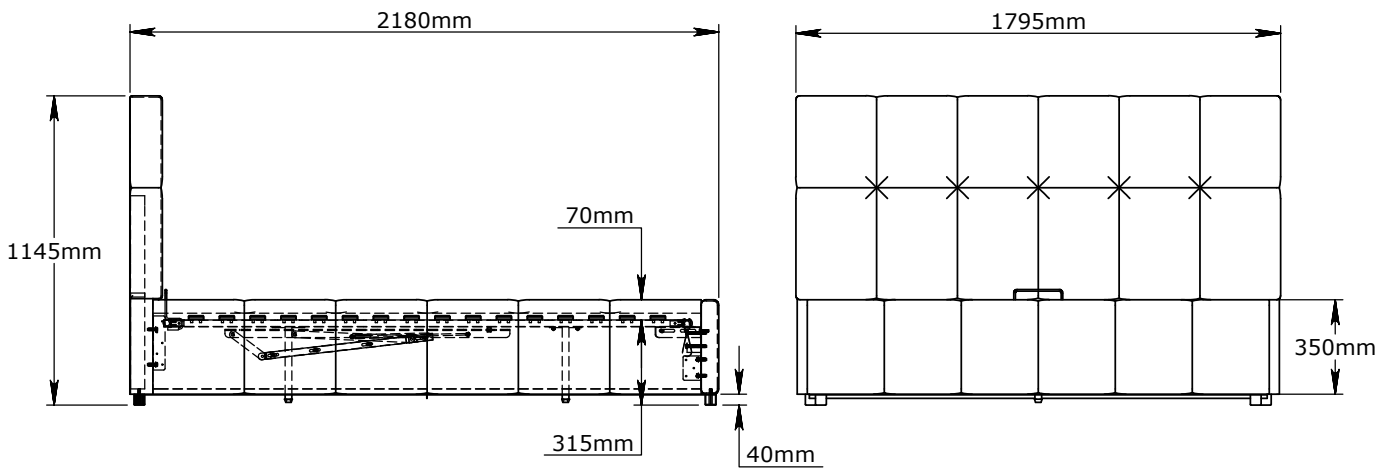
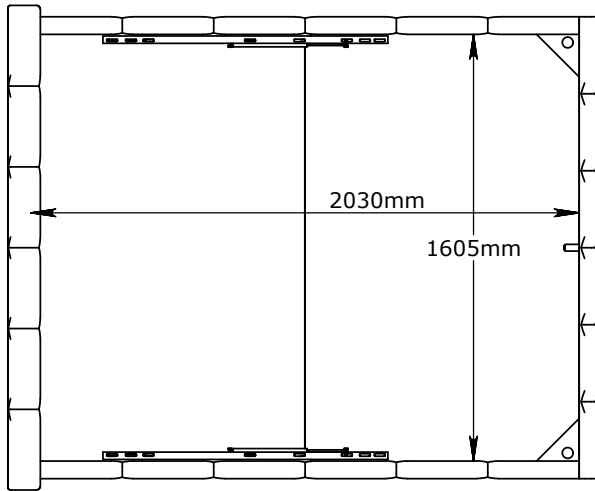
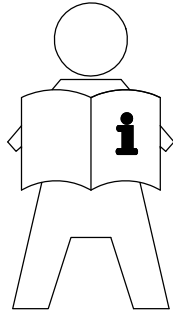

EN: IMPORTANT INFORMATION!

Please read the entire manual carefully before starting to assemble and/or using this product. Follow the manual thoroughly and keep it for further reference.

FR: INFORMATIONS IMPORTANTES

Veillez lire attentivement l'ensemble du manuel avant de commencer à monter et/ou utiliser ce produit. Suivez rigoureusement le manuel et conservez-le pour toute consultation ultérieure.

LV: SVARĪGA INFORMĀCIJA!

Pirms šī izstrādājuma montāžas un/vai lietošanas uzsākšanas pilnībā izlasiet lietošanas pamācību. Stingri ievērojiet pamācības norādījumus un saglabājiet to turpmākai lietošanai.

LT: SVARBI INFORMACIJA!

Prieš pradėdami montuoti gaminį ir (arba) juo naudotis, prašome atidžiai perskaityti visą vadovą. Atidžiai skaitykite vadovą ir turėkite jį su savimi, kad galėtumėte toliau vadovautis jo nuorodomis.

EE: OLULINE TEAVE!

Enne kui alustate toote kokku panemist ja/või kasutamist, lugege see kasutusjuhend hoolikalt läbi. Järgige täpselt juhendis toodud juhiseid ja hoidke juhend alles.

RU: ВАЖНАЯ ИНФОРМАЦИЯ!

Внимательно и полностью прочитайте это руководство, прежде чем приступать к сборке или использованию этого изделия. Следуйте всем инструкциям этого руководства и сохраните его на будущее для справки.



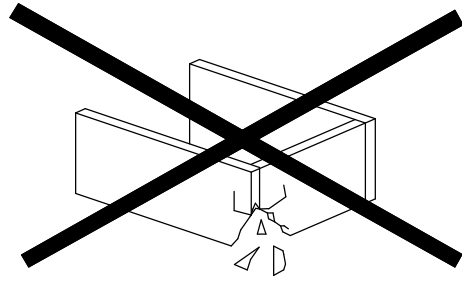
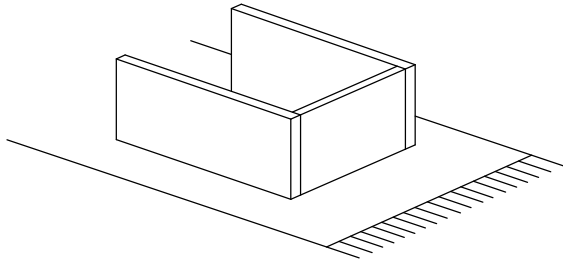

EN: WARNING TO AVOID SCRATCHES!

In order to avoid scratching this furniture should be assembled on a soft layer - could be a rug.

FR: AVERTISSEMENT POUR ÉVITER LES RAYURES

Afin d'éviter les rayures, ce meuble doit être monté sur une surface souple (un tapis, par exemple).

LV: BRĪDINĀJUMS PAR SKRĀPĒJUMIEM!

Lai nesaskrāpētu šo izstrādājumu, veiciet montāžu uz mīkstas pamatnes, piemēram, paklāja.

LT: ĮSPĖJIMAS, KAD IŠVENGTUMĖTE ĮBRĖŽIMŲ!

Šio baldo nesubraižysite, jei jį surinksite ant švelnaus paviršiaus, pavyzdžiui, kilimo.

EE: HOIATUS KRIIMUSTUSTE VÄLTIMISEKS!

Kriimustuste tekkimise vältimiseks mööblile tuleb see kokku panna pehmel pinnal, nt kaltsuvaibal.

RU: ПРЕДУПРЕЖДЕНИЕ ОТНОСИТЕЛЬНО ЦАРАПИН!

Во избежание нанесения царапин, сборку этой мебели необходимо выполнять на мягкой поверхности, например на ковре.



EN: **IMPORTANT!**

It is important that any product which is assembled using any kind of screw is re-tightened 2 weeks after assembly, and once every 3 months - in order to assure stability through-out the lifespan of the product.

FR: **IMPORTANT**

Il est important que tout produit monté à l'aide de vis soit resserré 2 semaines après son montage, puis tous les 3 mois, afin de garantir sa stabilité durant tout son cycle de vie.

LV: **SVARĪGI!**

Ir svarīgi, lai jebkuram produktam, kas tiek uzstādīts ar jebkādu skrūvju palīdzību, skrūves tiktu atkārtoti pievilktas 2 nedēļas pēc montāžas, pēc tam – reizi 3 mēnešos, tā nodrošinot stabilitāti visā izstrādājuma kalpošanas laikā.

LT: **SVARBU!**

Bet kokį varžtais tvirtinamą gaminį 2 savaites po surinkimo bei kas 3 mėnesius reikia papildomai suveržti - taip užtikrinamas naudojamą gaminio stabilumas.

EE: **TÄHTIS!**

Oluline on, et toote kruvisid pingutataks 2 nädalat pärast kokkupanekut ja seejärel iga 3 kuu järel, et tagada stabiilsus kogu toote eluea jooksul.

RU: **ВАЖНО!**

В любом изделии, собранном с использованием винтов любого типа, необходимо через 2 недели после сборки и в дальнейшем каждые 3 месяца подтягивать винты, чтобы обеспечить прочность изделия в течение срока эксплуатации.





EN: GENERAL INSTRUCTION FOR FURNITURE WITH FABRIC!

Wipe clean with a damp cloth. Use only clean water.
Dust and dirt can be vacuum cleaned or wiped with a clean soft cloth.
Do not use detergents, solvents or other chemicals on fabric as this may cause discoloration.
However, certain removable fabrics may be washed, but in such cases there will ALWAYS be a washing instruction on the fabric.

FR: INSTRUCTIONS GÉNÉRALES POUR LE MOBILIER EN TISSU!

Nettoyez à l'aide d'un chiffon humide. N'utilisez que de l'eau claire.
La poussière et la saleté peuvent être aspirées ou essuyées à l'aide d'un chiffon doux et propre.
N'utilisez aucun détergent, solvant ou autre produit chimique sur le tissu, car ceci pourrait le décolorer.
Cependant, certains tissus amovibles peuvent être lavés, mais dans ce cas le tissu comportera TOUJOURS des instructions de lavage.

LV: VISPĀRĪGI KOPŠANAS NORĀDĪJUMI MĒBELĒM AR AUDUMU!

Noslaukiet ar mitru drānu. Izmantojiet tikai tīru ūdeni.
Putekļus un netīrumus var notīrīt ar putekļusūcēju vai noslaucīt ar mīkstu drānu.
Auduma tīrīšanai neizmantojiet mazgāšanas līdzekļus, šķīdinātājus vai citas ķīmikālijas, jo auduma krāsa var izbalēt.
Atsevišķus noņemamos audumus var mazgāt, taču tad uz auduma VIENMĒR būs sniegti kopšanas norādījumi.

LT: BENDROSIS INSTRUKCIJOS BALDAMS PADENGTIEMS AUDINIUI!

Svariai nušluostykite drėgna šluoste. Naudokite tik švarų vandenį.
Dulkės ir nešvarumai gali būti susiurbti arba nuvalyti švaria, minkšta šluoste.
Nenaudokite detergentų, tirpiklių ar kitų chemikalų audiniams, nes šie gali sukelti spalvos išblukimą.
Visgi, kai kurie nuimami audiniai gali būti skalbiami, bet tokiais atvejais ant audinio etiketės VISADA turi būti pateiktos skalbimo instrukcijos.

EE: ÜLDISED JUHISED KANGAGA MÖÖBLI JAOKS!

Puhastage niiske lapiga. Kasutage ainult puhast vett.
Tolmu ja mustust saab eemaldada tolmuimejaga või ära pühkida puhta pehme lapiga.
Ärge kasutage kangal pesuvahendeid, lahusteid või muid kemikaale, kuna see võib põhjustada värvimuutusi.
Küll aga võib teatud eemaldatavaid kangaid pesta, kuid sellisel juhul on kanga küljes ALATI pesujuhend.

RU: ОБЩИЕ УКАЗАНИЯ ПО УХОДУ ЗА МЕБЕЛЬЮ С ОТДЕЛКОЙ ИЗ ТКАНИ!

Очистите изделие чистой влажной тряпкой. Используйте только чистую воду.
Пыль и грязь можно удалять пылесосом или чистой мягкой тряпкой.
Не наносите моющие средства, растворители или другие химические вещества на ткань, поскольку они могут привести к вымыванию цвета.
Некоторые съемные элементы из ткани можно стирать.
В таких случаях к ткани ОБЯЗАТЕЛЬНО прилагается инструкция по стирке.

EN: WARNING FOR FINGER ENTRAPMENT:

*Be cautious of potential finger entrapment hazards when assembling, using, adjusting or disassembling the product, due to its moving parts.
The product must only be used by children under adult supervision.*

FR: AVERTISSEMENT RISQUE PINCEMENT DES DOIGTS:

*En raison de pièces mobiles, merci de bien faire attention au risque de pincement de doigts lors de l'assemblage, de l'utilisation, du réglage ou du démontage du produit.
Le produit ne doit être utilisé par des enfants que sous la surveillance d'un adulte.*

LV: BRĪDINĀJUMS PAR PIRKSTU IESPIEŠANU:

*Uzstādot, lietojot, regulējot vai izjaucot izstrādājumu, jāuzmanās no iespējama pirkstu iespiešanas riska tā kustīgo daļu dēļ.
Bērni šo izstrādājumu drīkst lietot tikai pieaugušo uzraudzībā.*

LT: ĮSPĖJIMAS DĖL PIRŠTŲ ĮSTRIGIMO:

*Montuodami, naudodami, reguliuodami ar išardydami gaminį dėl judančių dalių būkite atsargūs – saugokite pirštus nuo įstrigimo.
Vaikai gali naudoti gaminį tik prižiūrimi suaugusiųjų.*

EE: HOIATUS SÕRMEDE VAHELEJÄÄMISE OHU EEST:

*Toote kokkupanekul, kasutamisel, reguleerimisel või koost lahti võtmisel olge ettevaatlik – liikuvatest osadest tulenev sõrmede vahelejäämise oht.
Toodet tohivad kasutada ainult lapsed täiskasvanu järelevalve all.*

RU: ПРЕДУПРЕЖДЕНИЕ ОБ ОПАСНОСТИ ЗАЩЕМЛЕНИЯ ПАЛЬЦЕВ:

*При сборке, использовании, регулировке или разборке изделия соблюдайте осторожность, поскольку движущиеся элементы изделия могут защемить пальцы.
Дети могут использовать изделие только под наблюдением взрослых.*



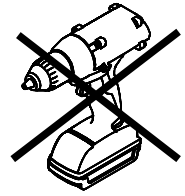
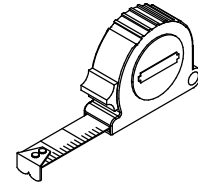

A x 16



M8x30mm

B x 12

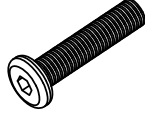

M8x35mm

C x 2

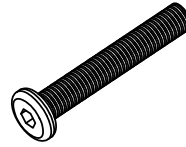

M8x50mm

D x 2

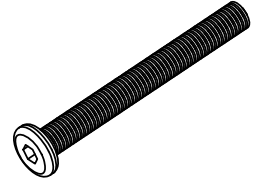

M8x70mm

E x 2

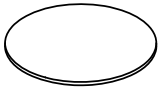

∅40x3mm

F x 8



∅8mm

G x 18

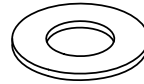

∅8/∅18mm

H x 14

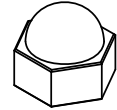

M8/13mm

J x 1



220x30mm

K x 1

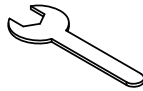

13mm

L x 1

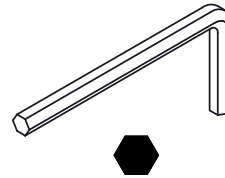

5mm

M x 4

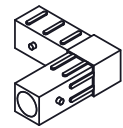

73x73x25mm

N x 4

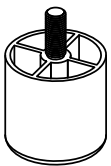

∅40x40mm

P x 1



97x50x26mm

Q x 32

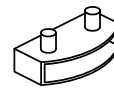

56x29x12mm

R x 16

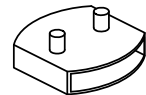

56x50x12mm

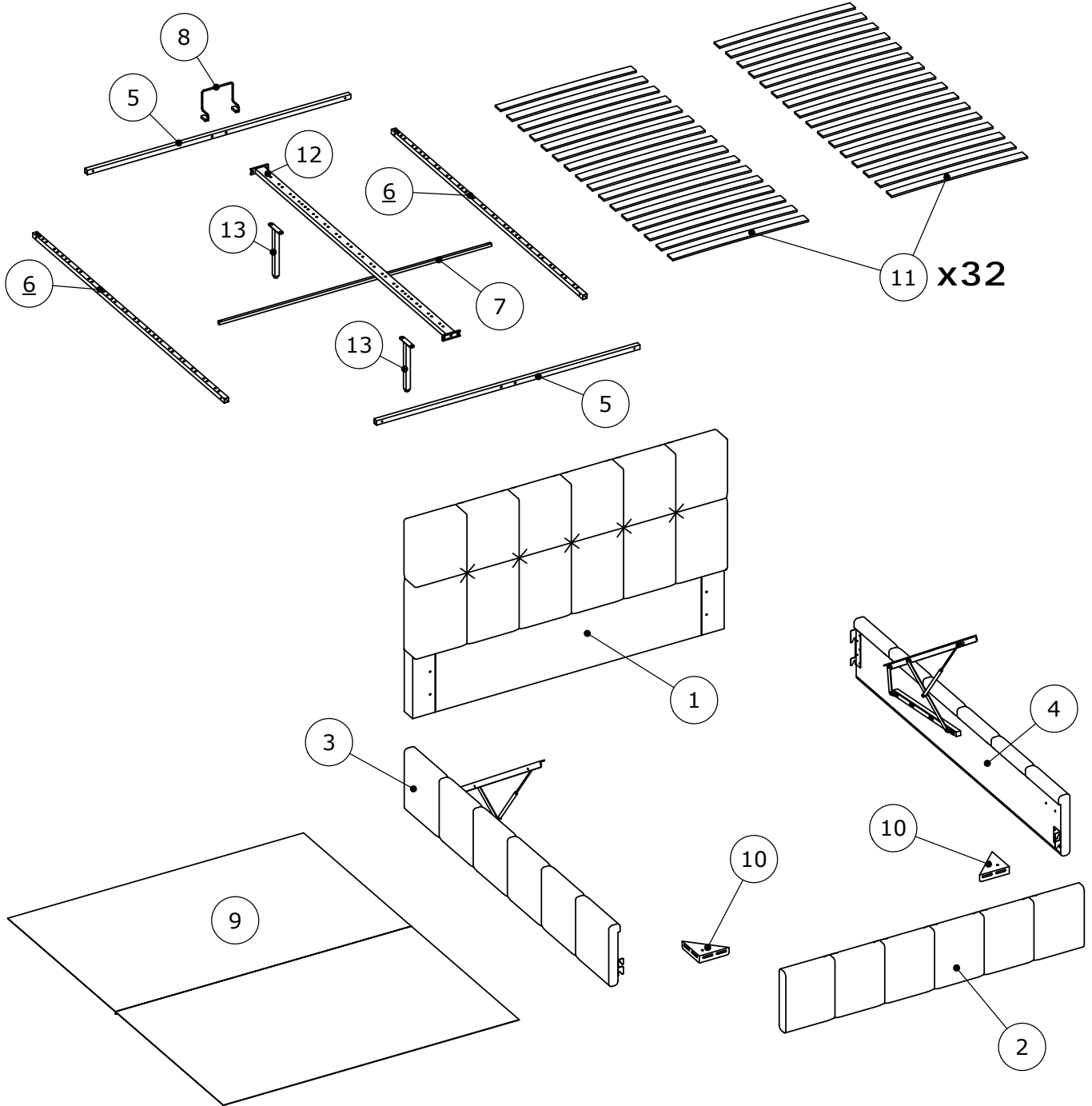
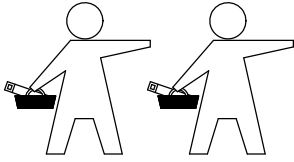

Box 1/1:

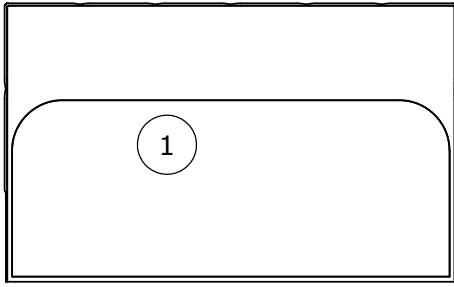

1795×1105×120mm

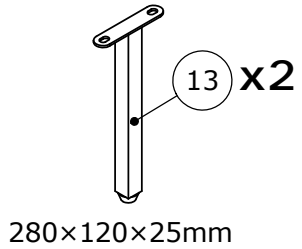
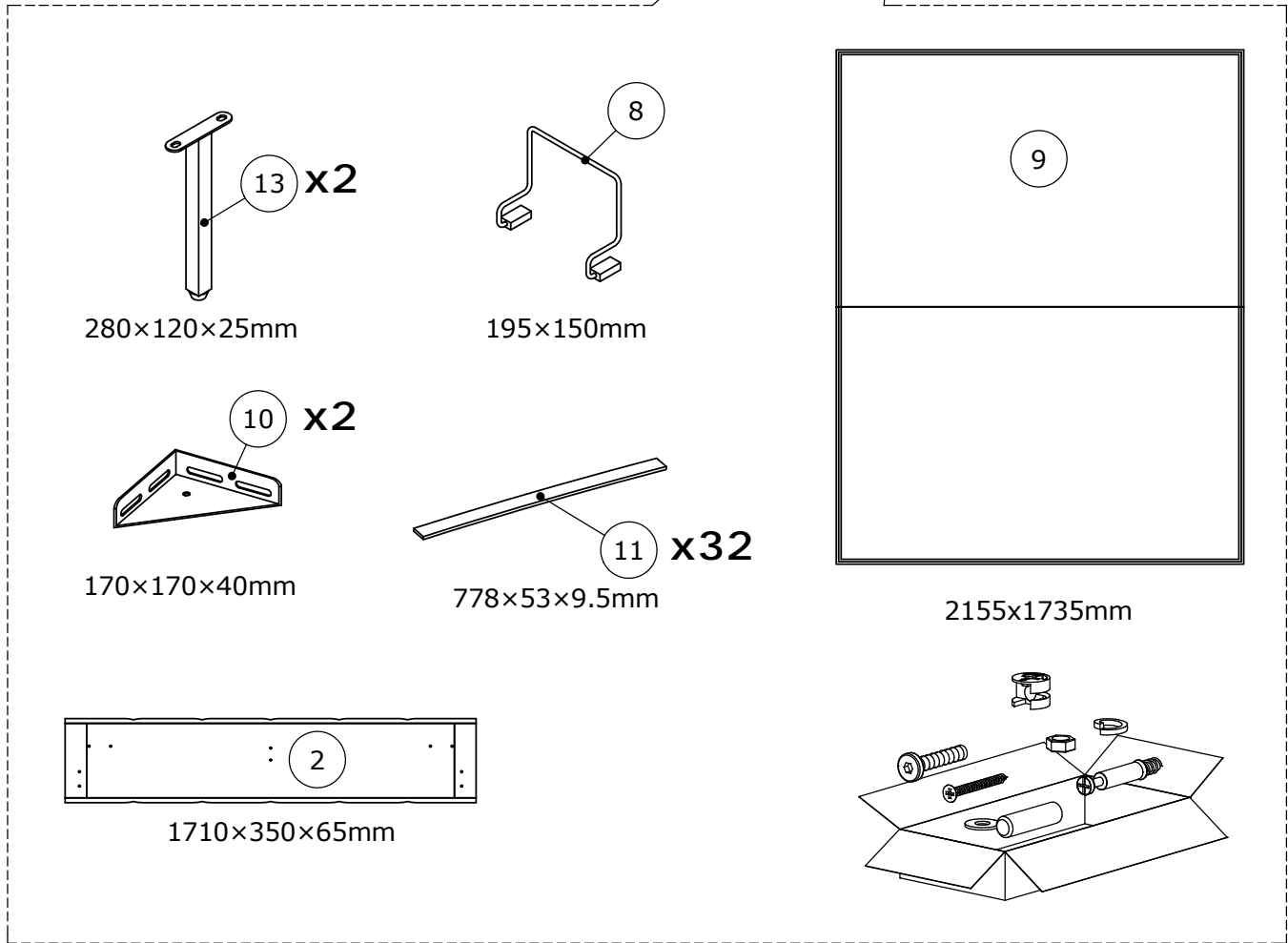
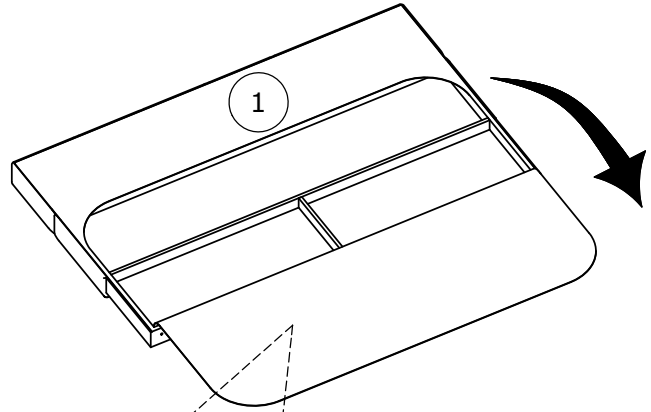

280×120×25mm

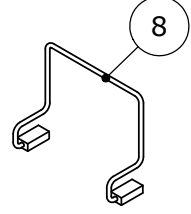

195×150mm

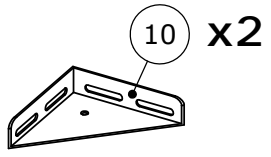

170×170×40mm

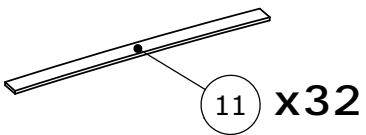

778×53×9.5mm

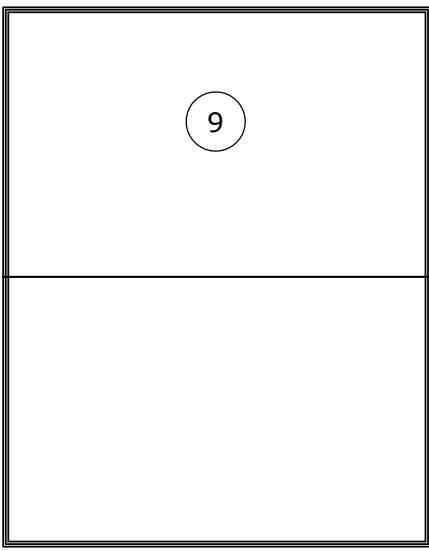

2155×1735mm

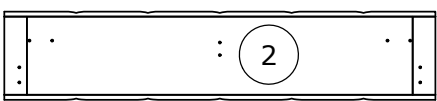

1710×350×65mm

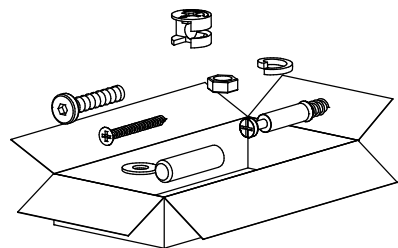

Box 2/2:

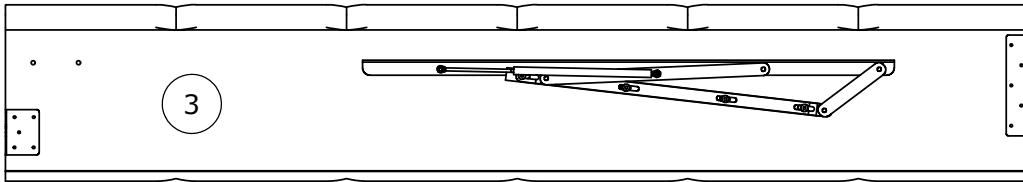

2030x350x120mm

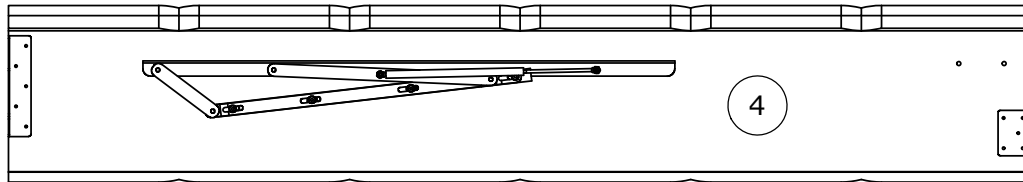

2030x350x120mm

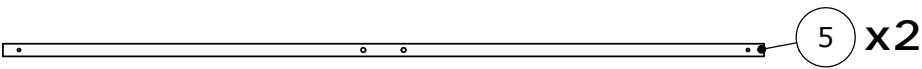

1510x25x25mm

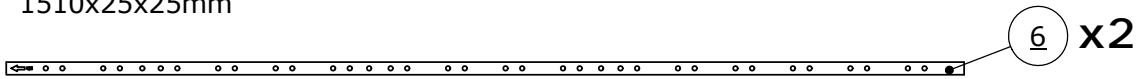

1900x25x25mm



1560x15x15mm

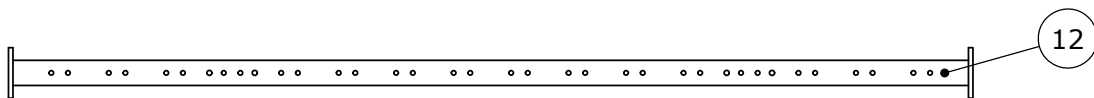

1913x100x30mm

1

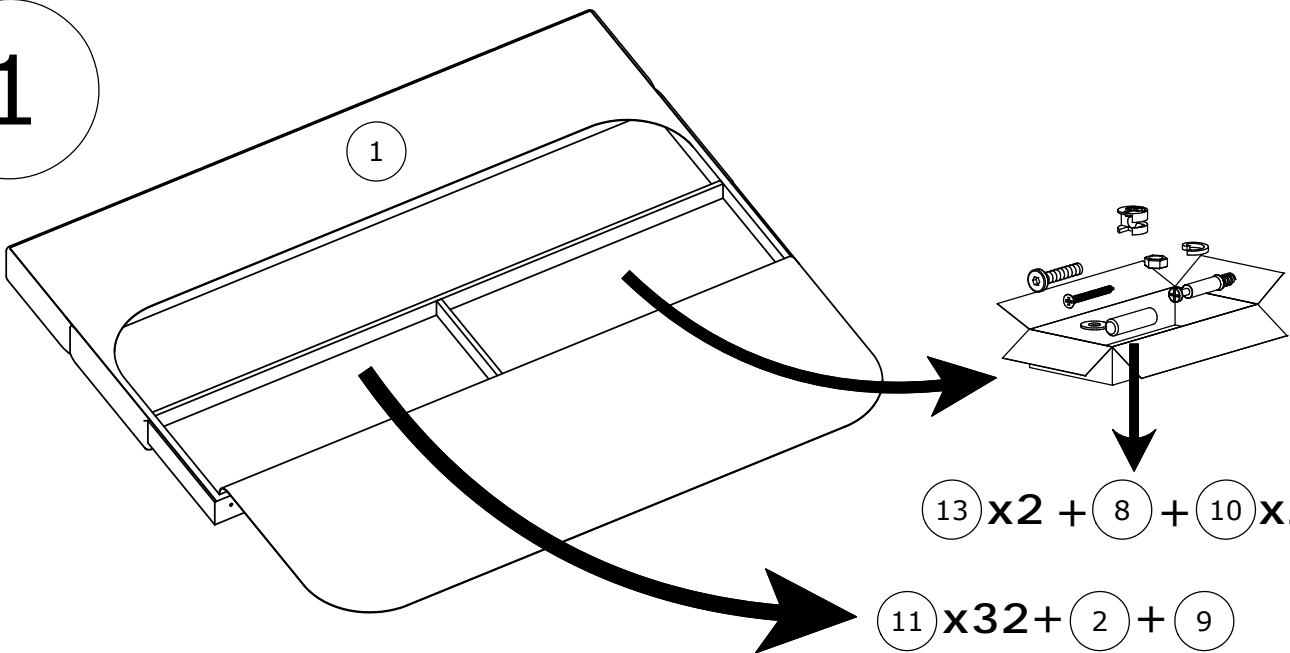

13 x 2 + 8 + 10 x 2

11 x 32 + 2 + 9

2

A x 8 M8x30mm	F x 8 ø8mm	G x 8 ø8/ø18mm	L x 1 5mm	
----------------------	-------------------	-----------------------	------------------	--

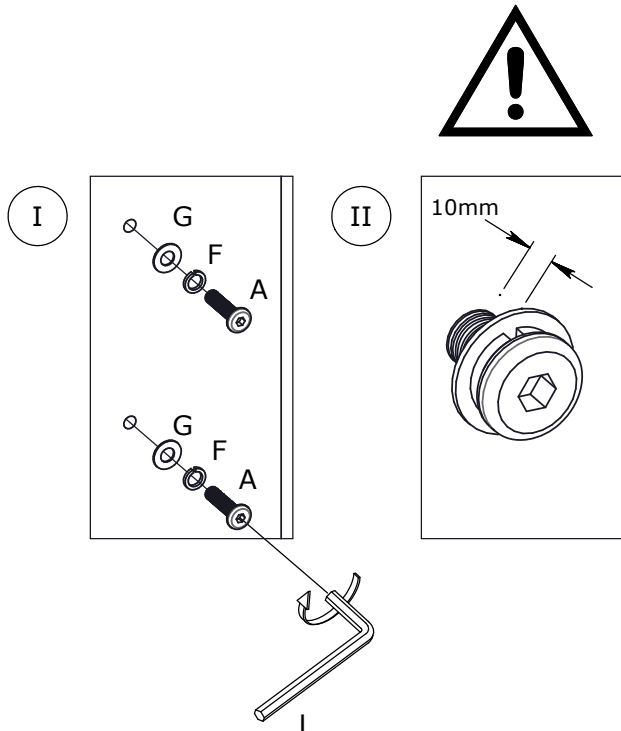
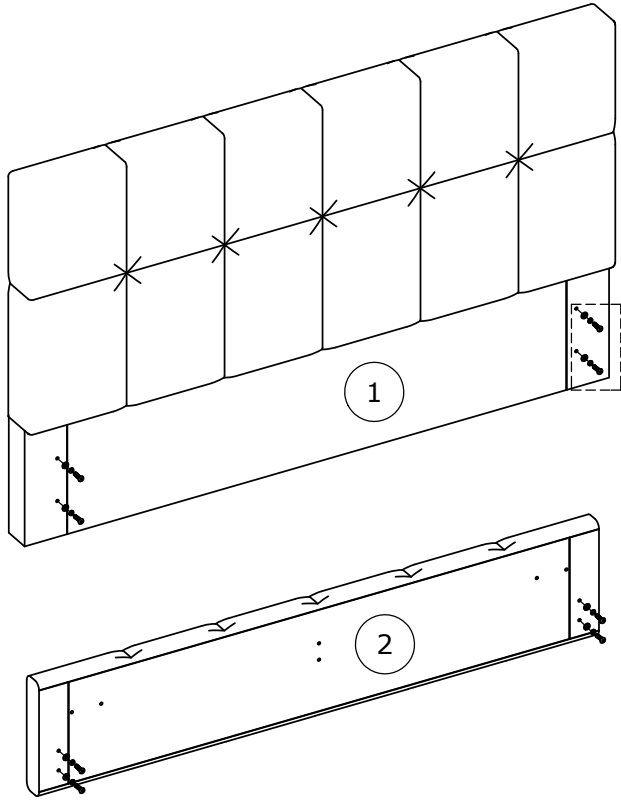
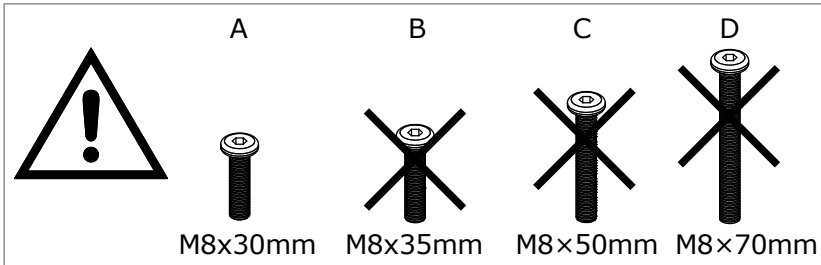

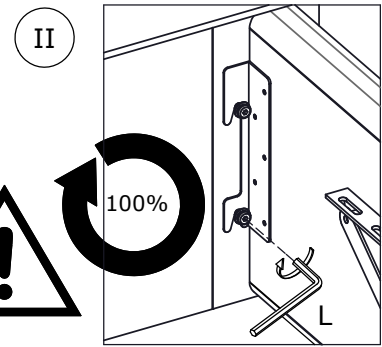
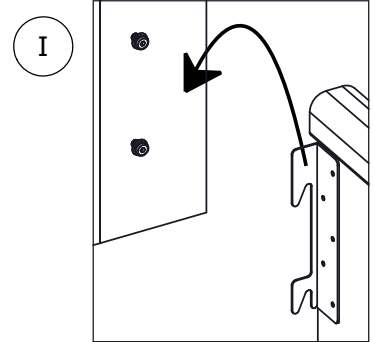
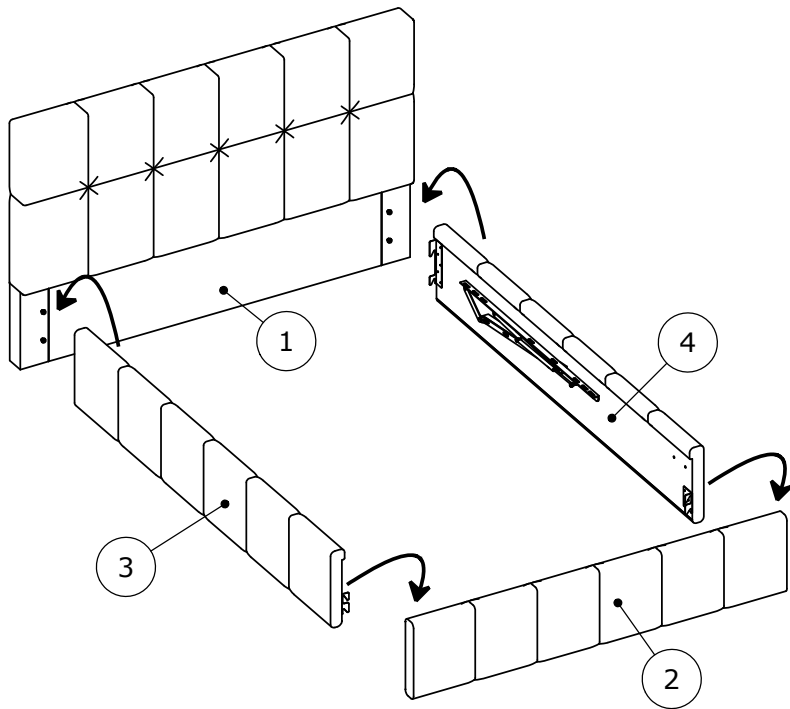
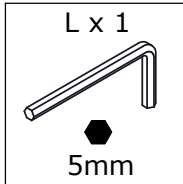

3

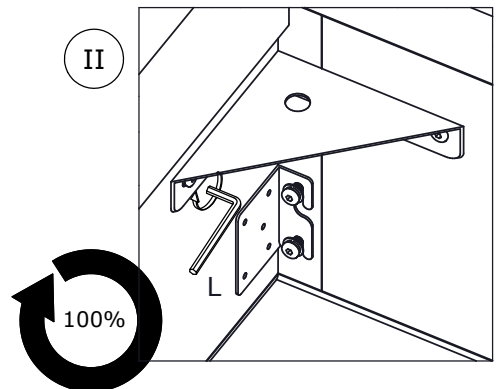
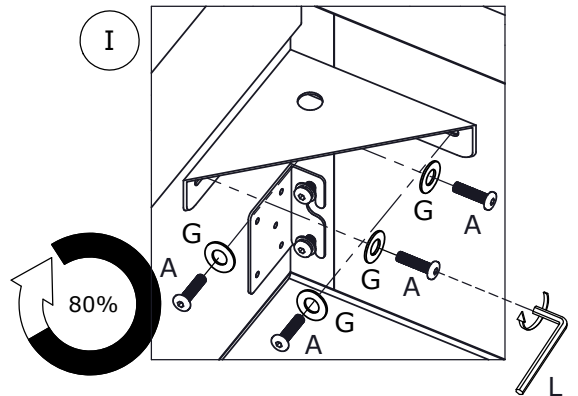
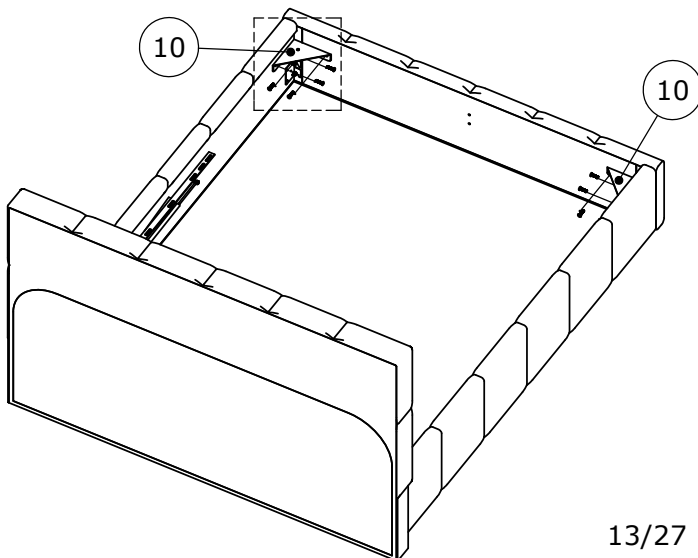
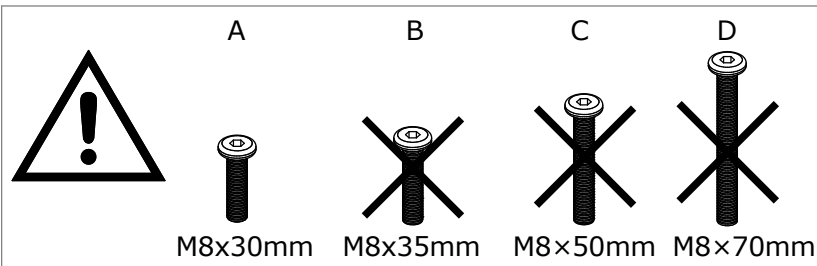
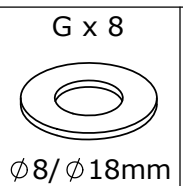
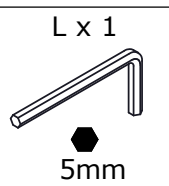
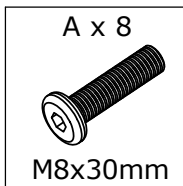

4

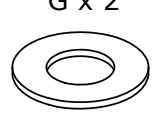
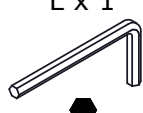

5

<p>D x 2</p>  <p>M8x70mm</p>	<p>G x 2</p>  <p>∅8/∅18mm</p>	<p>L x 1</p>  <p>5mm</p>	<p>P x 1</p>  <p>97x50x26mm</p>	
---	--	---	--	--

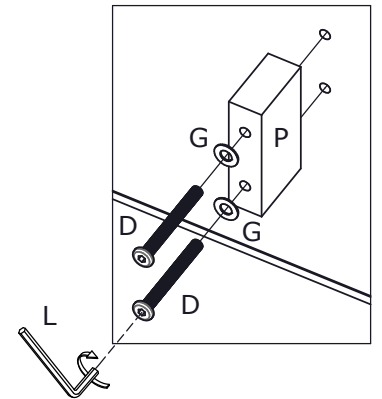
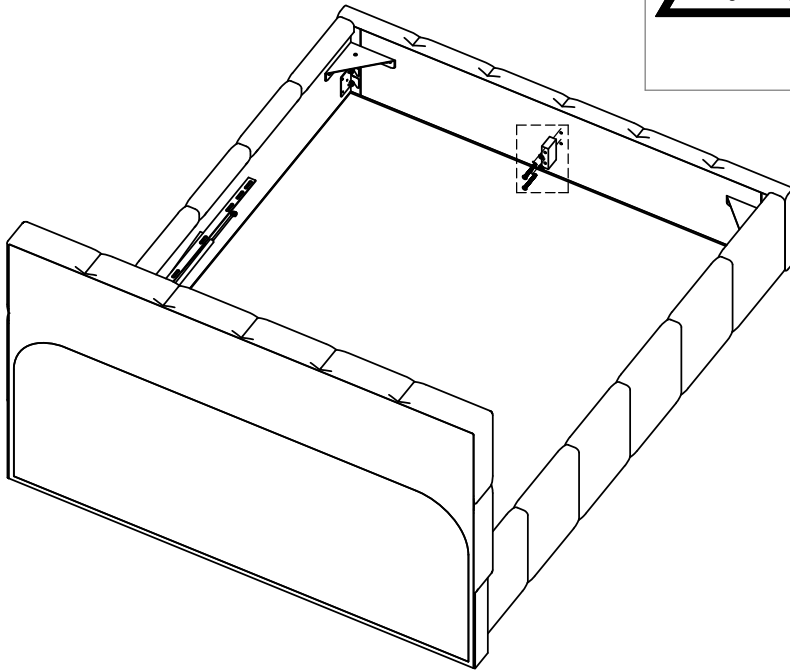
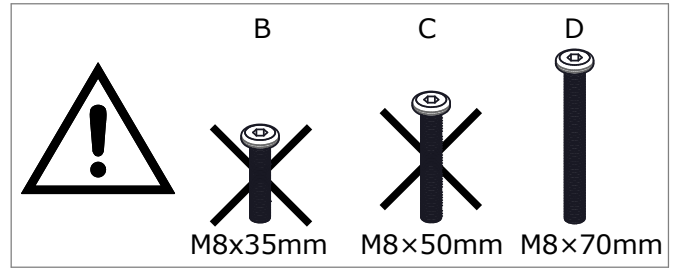

6

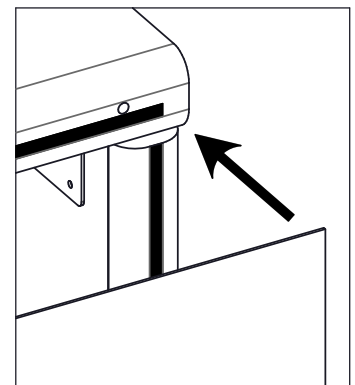
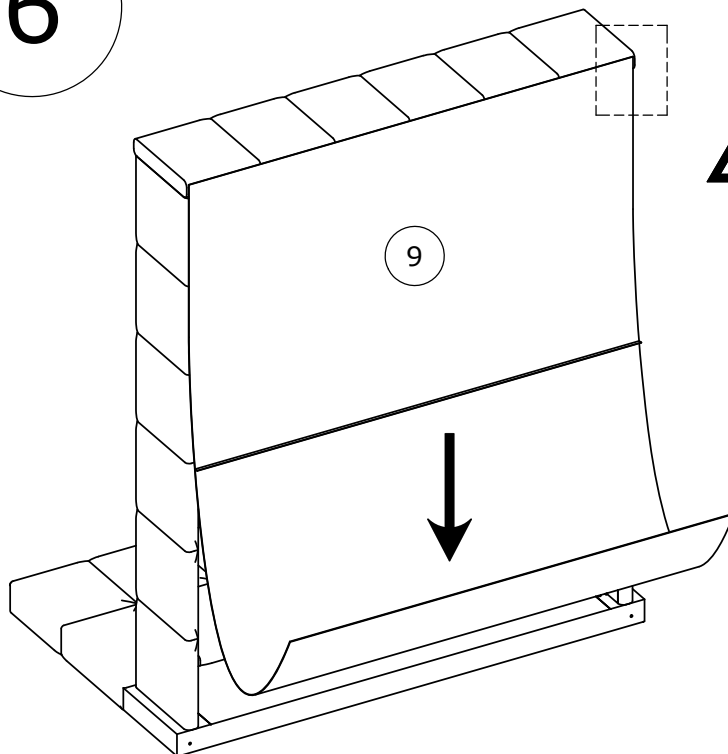

7

N x 4



Ø40x40mm

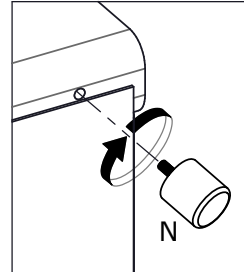
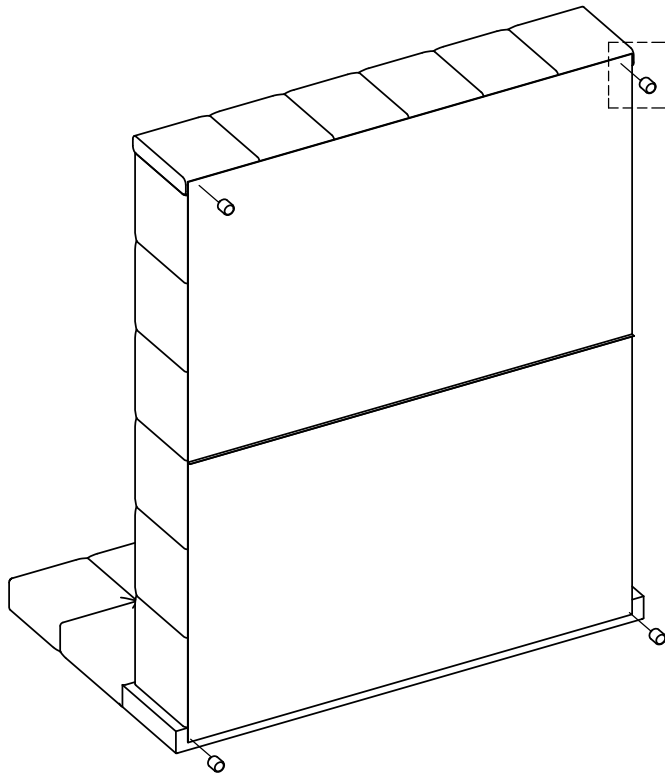

8



M x 2



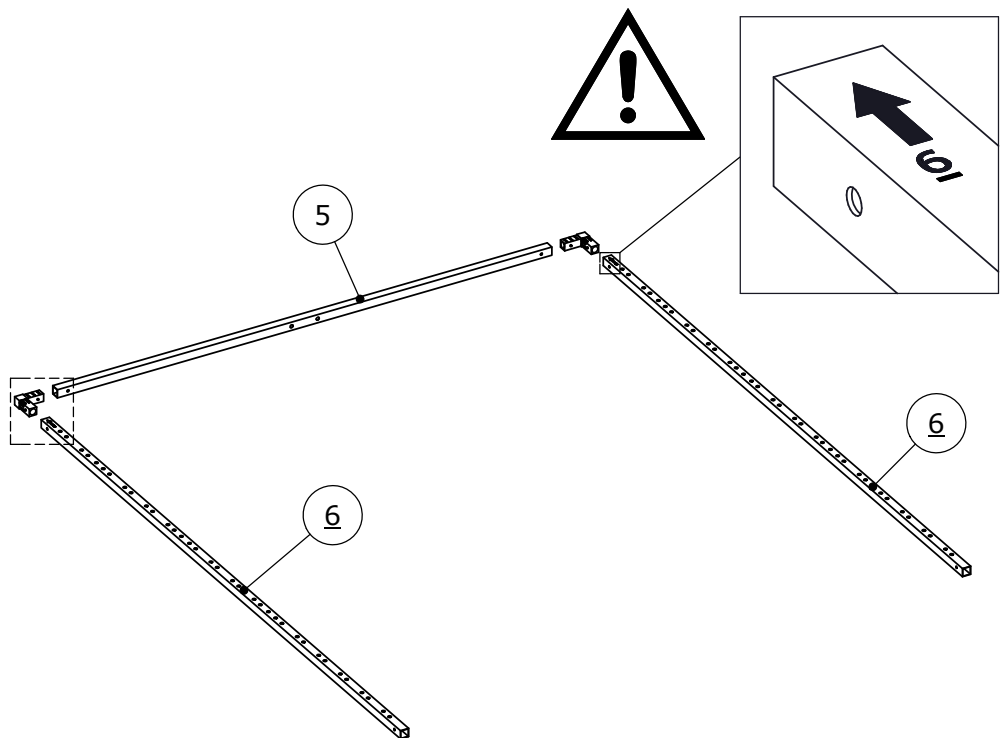
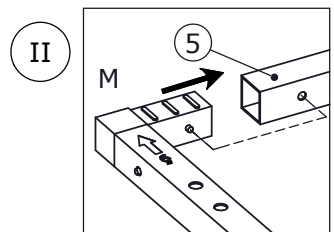
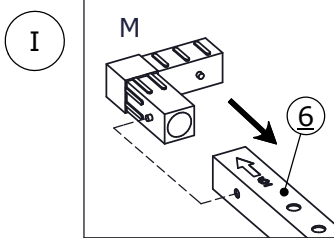

73x73x25mm

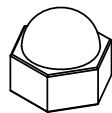

9

<p>B x 2</p>  <p>M8x35mm</p>	<p>H x 2</p>  <p>M8/13mm</p>	<p>L x 1</p>  <p>5mm</p>	<p>K x 1</p>  <p>13mm</p>	
---	---	---	---	--

	<p>B</p>  <p>M8x35mm</p>	<p>C</p>  <p>M8x50mm</p>
---	---	---

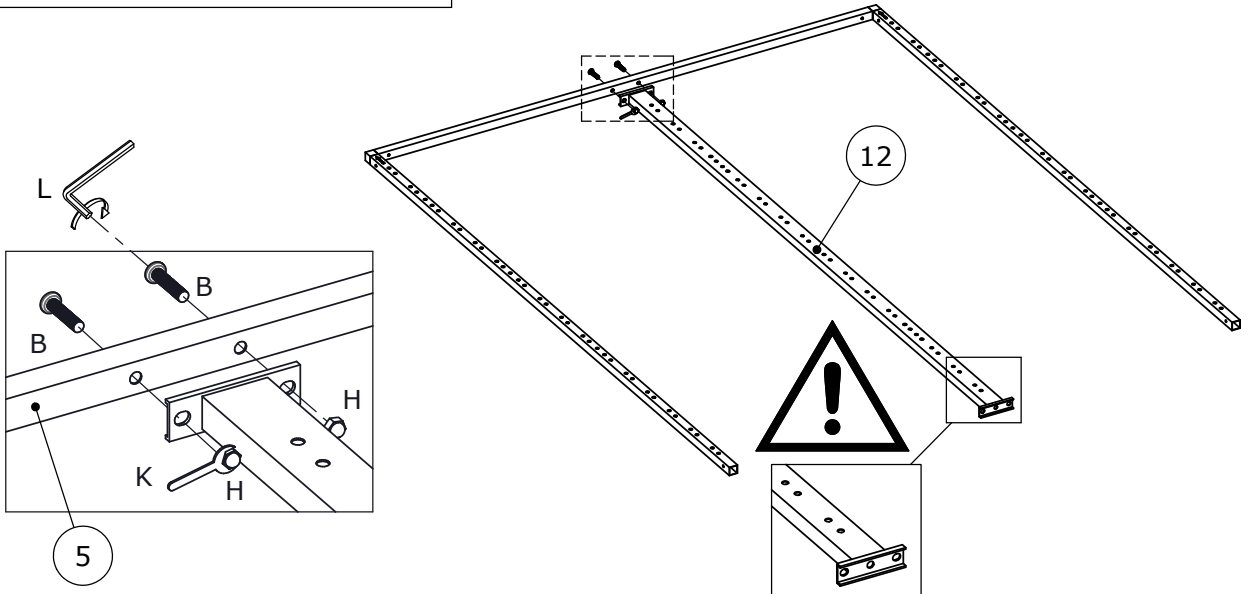

10

<p>J x 1</p>  <p>220x30mm</p>	
--	--

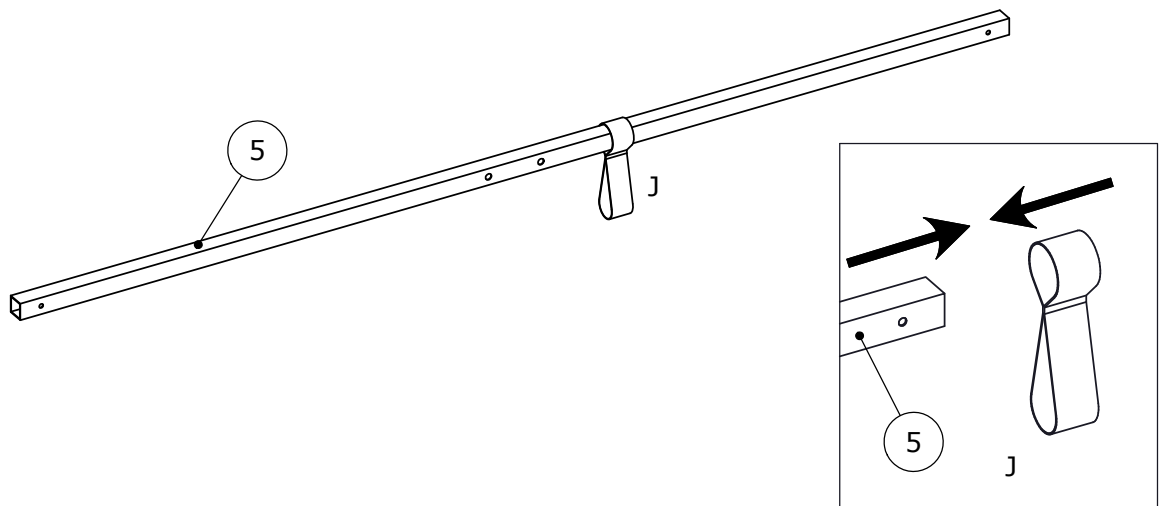

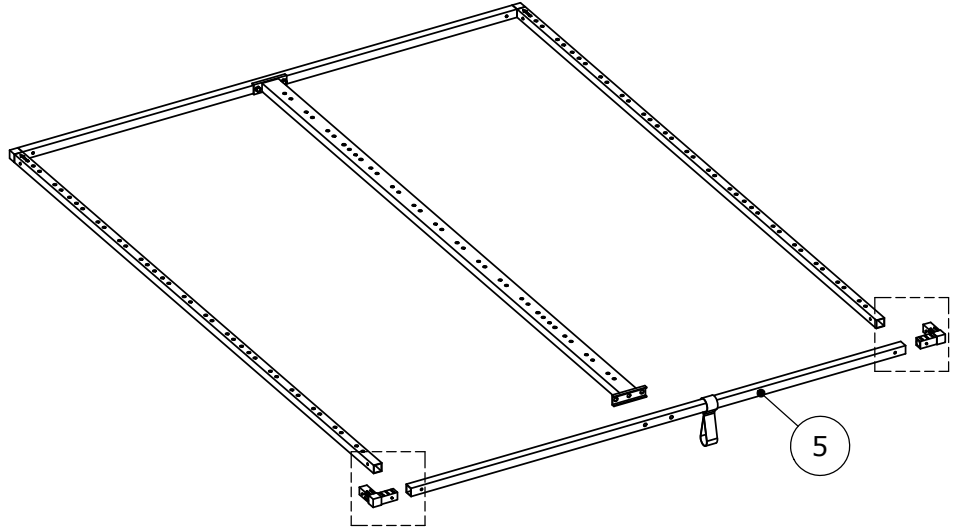
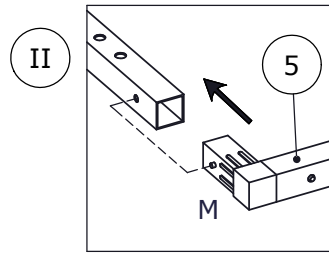
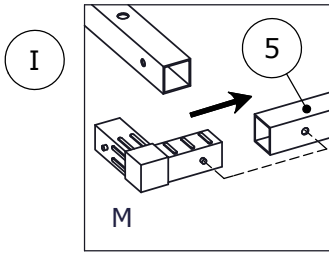

11

M x 2
73x73x25mm

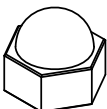

12

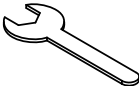
B x 2  M8x35mm	H x 2  M8/13mm	L x 1  5mm	K x 1  13mm	
---	---	---	---	--

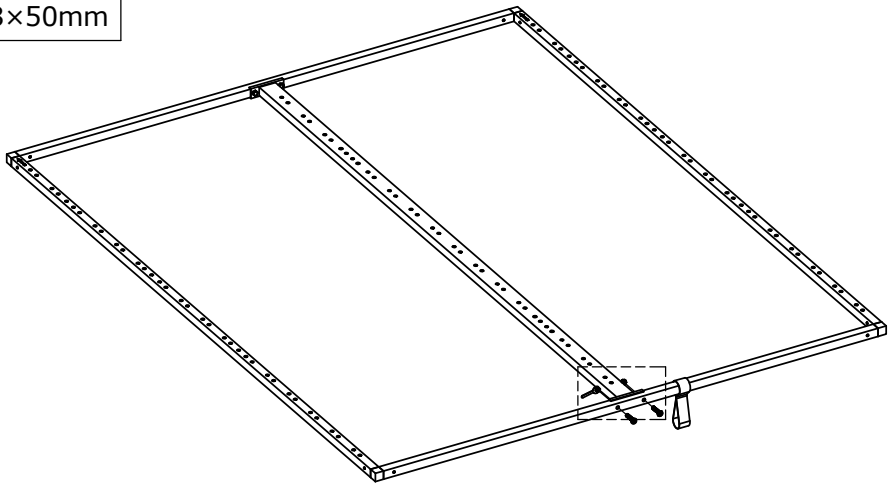
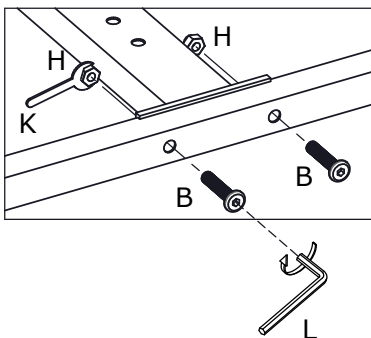
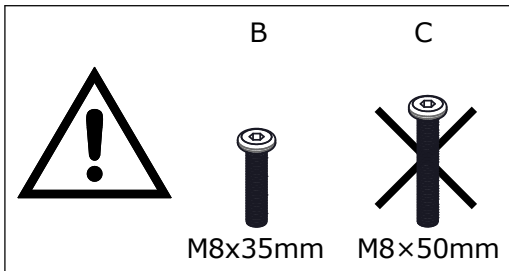



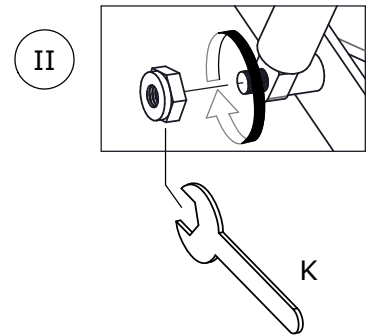
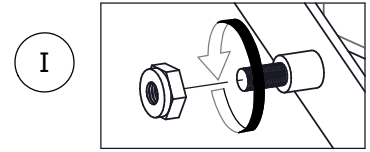
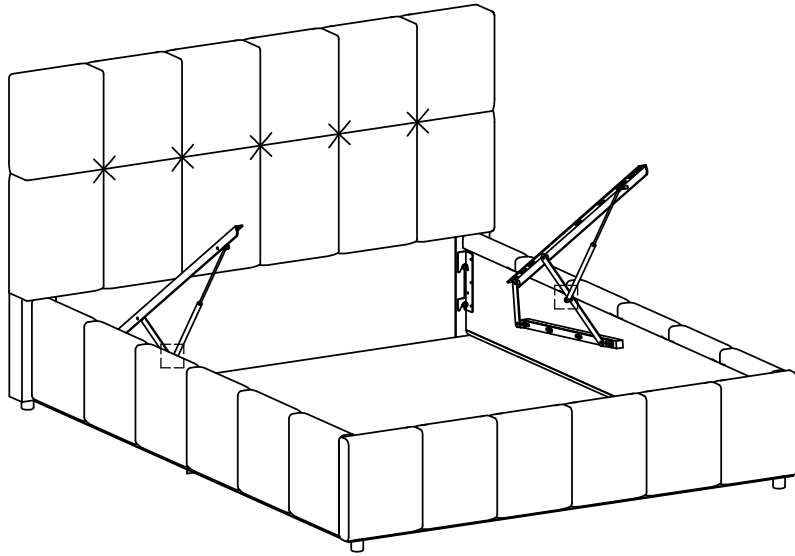

13

K x 1	
	
13mm	



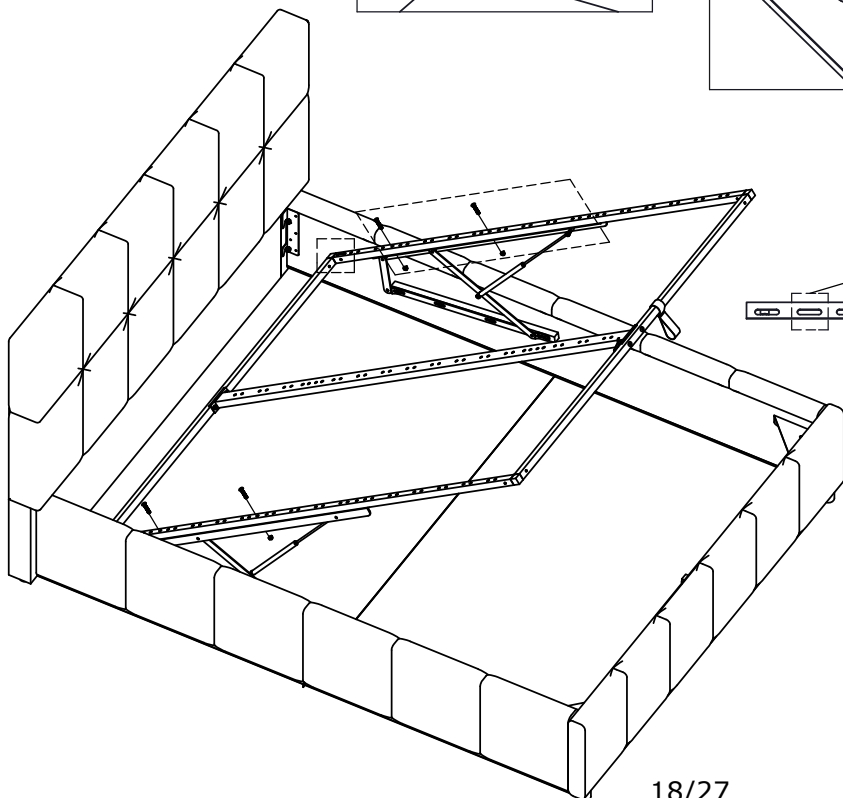
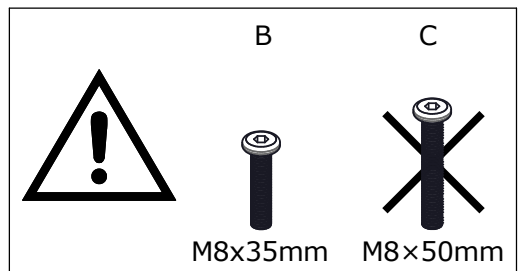
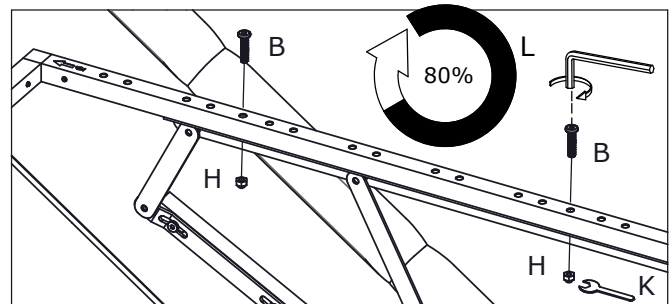
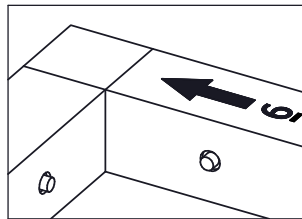

14

B x 4	H x 4	L x 1	K x 1	
				
M8x35mm	M8/13mm	5mm	13mm	

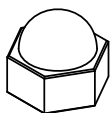

15

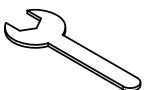
C x 2  M8x50mm	H x 2  M8/13mm	L x 1  5mm	K x 1  13mm	
---	---	---	---	--

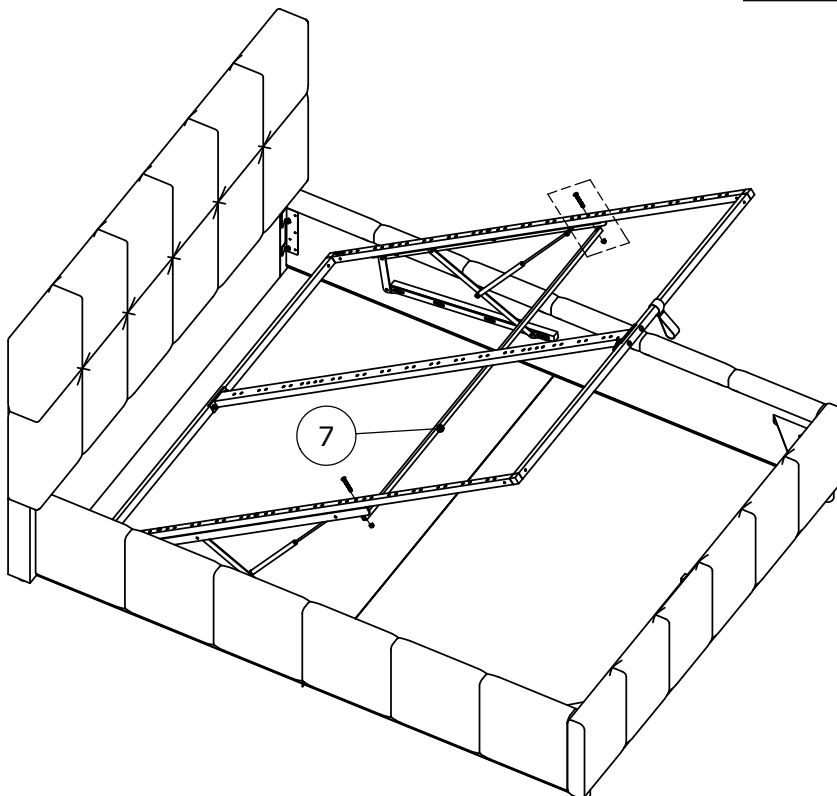
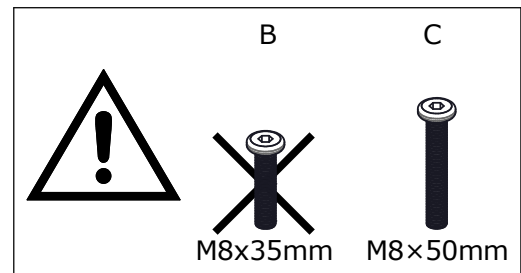
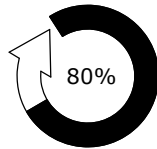
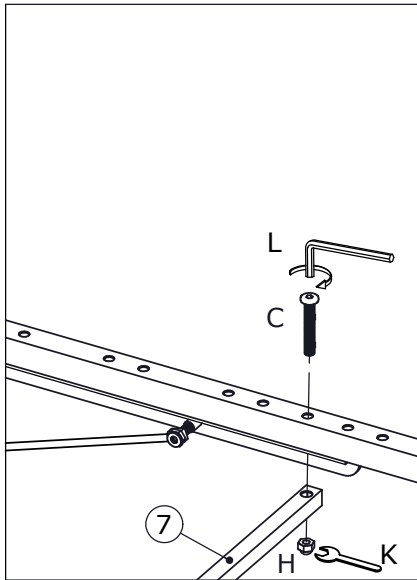

16

$L \times 1$  5mm	$K \times 1$  13mm	
--	---	---

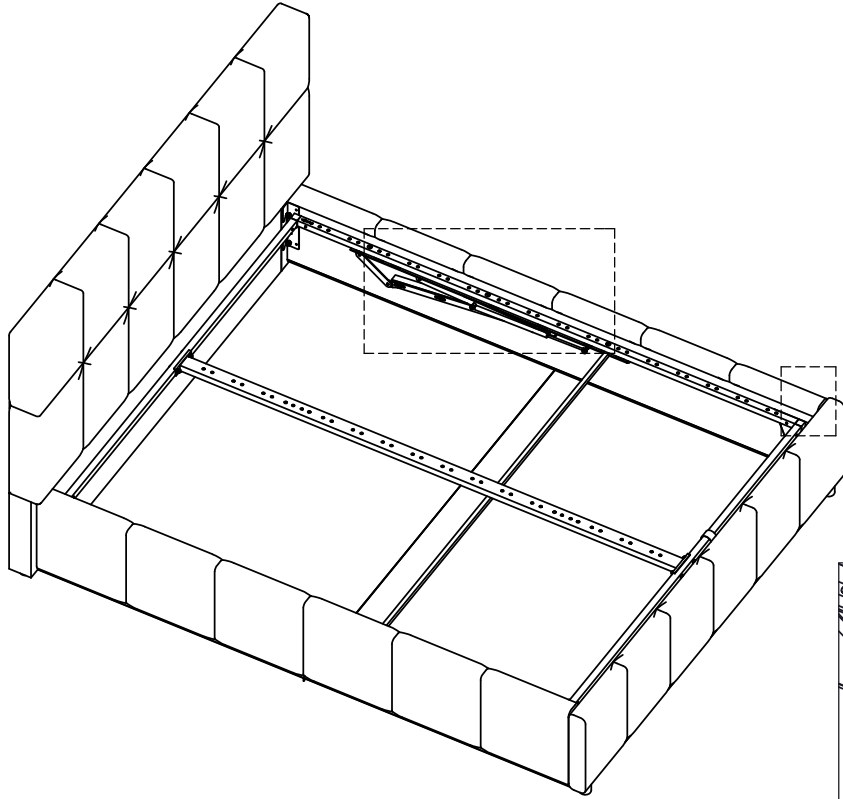



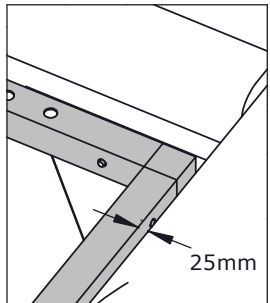

I

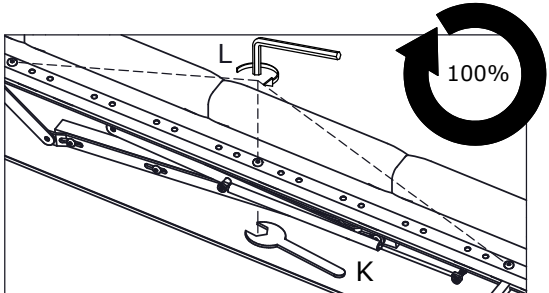

II



17

$B \times 4$  M8x35mm	$H \times 4$  M8/13mm	$L \times 1$  5mm	$K \times 1$  13mm	
--	--	--	--	--

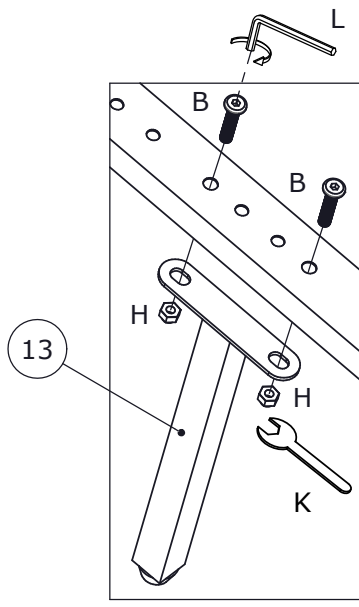
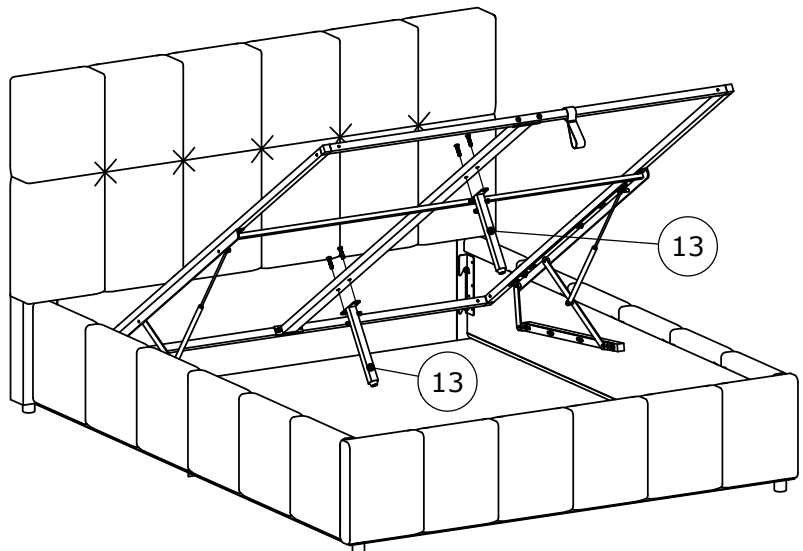

18

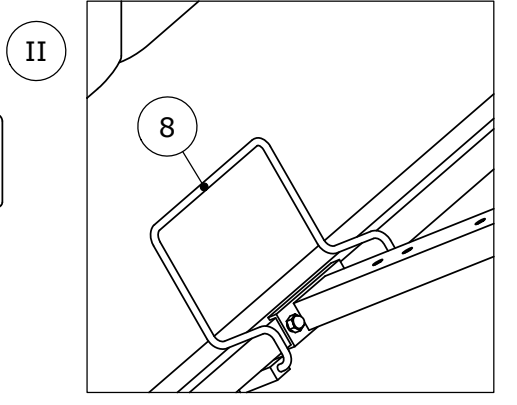
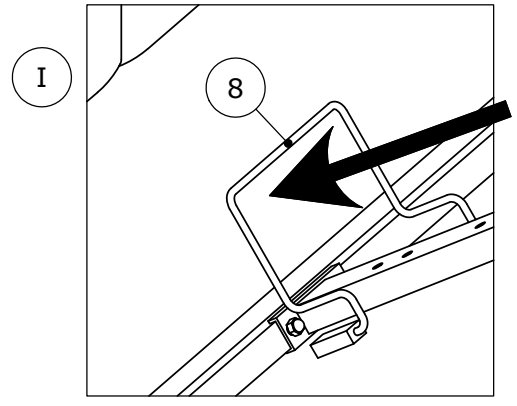
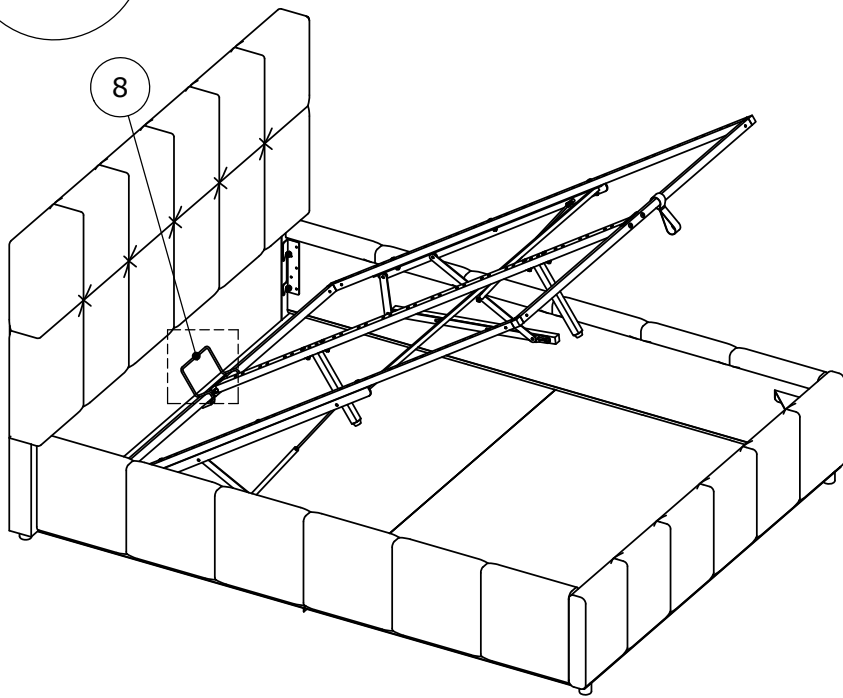

19

E x 2	
Ø 40x3mm	

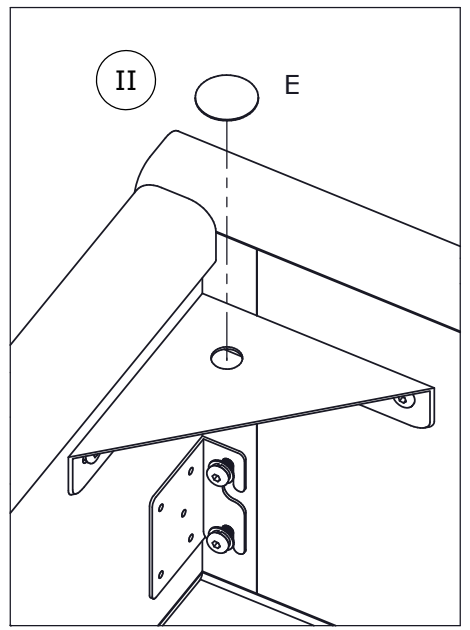
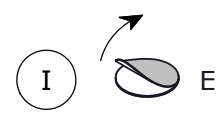
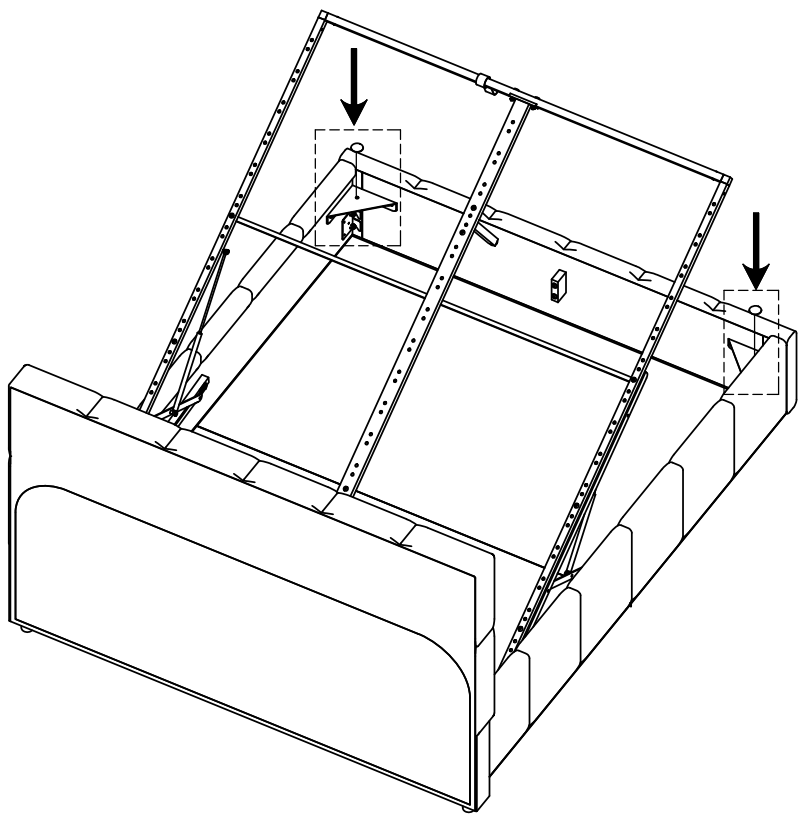

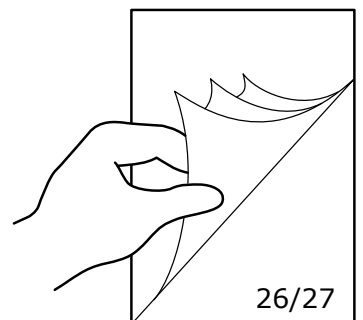
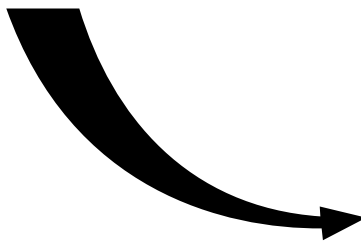
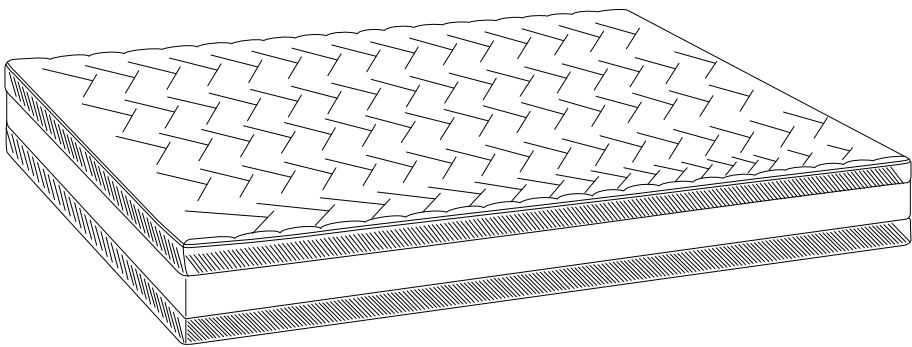
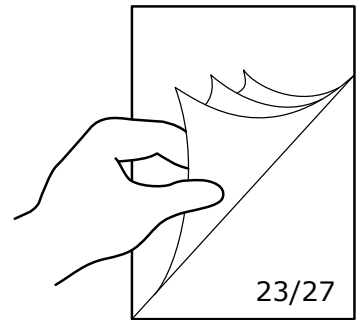
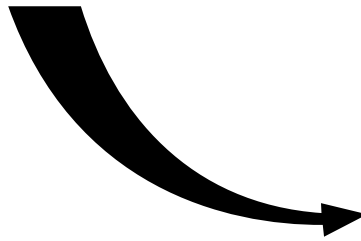
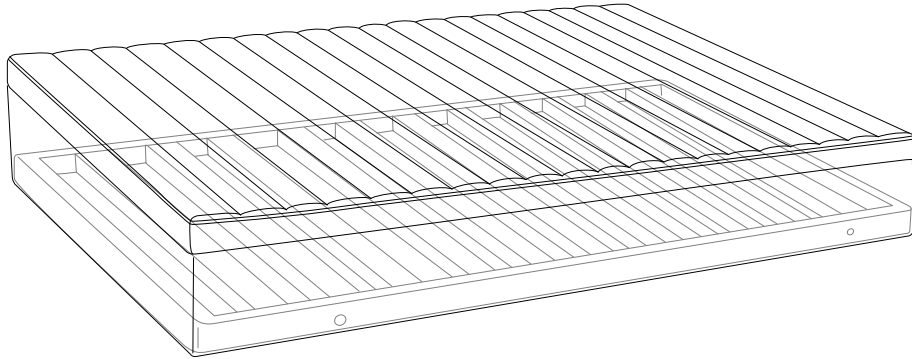

20

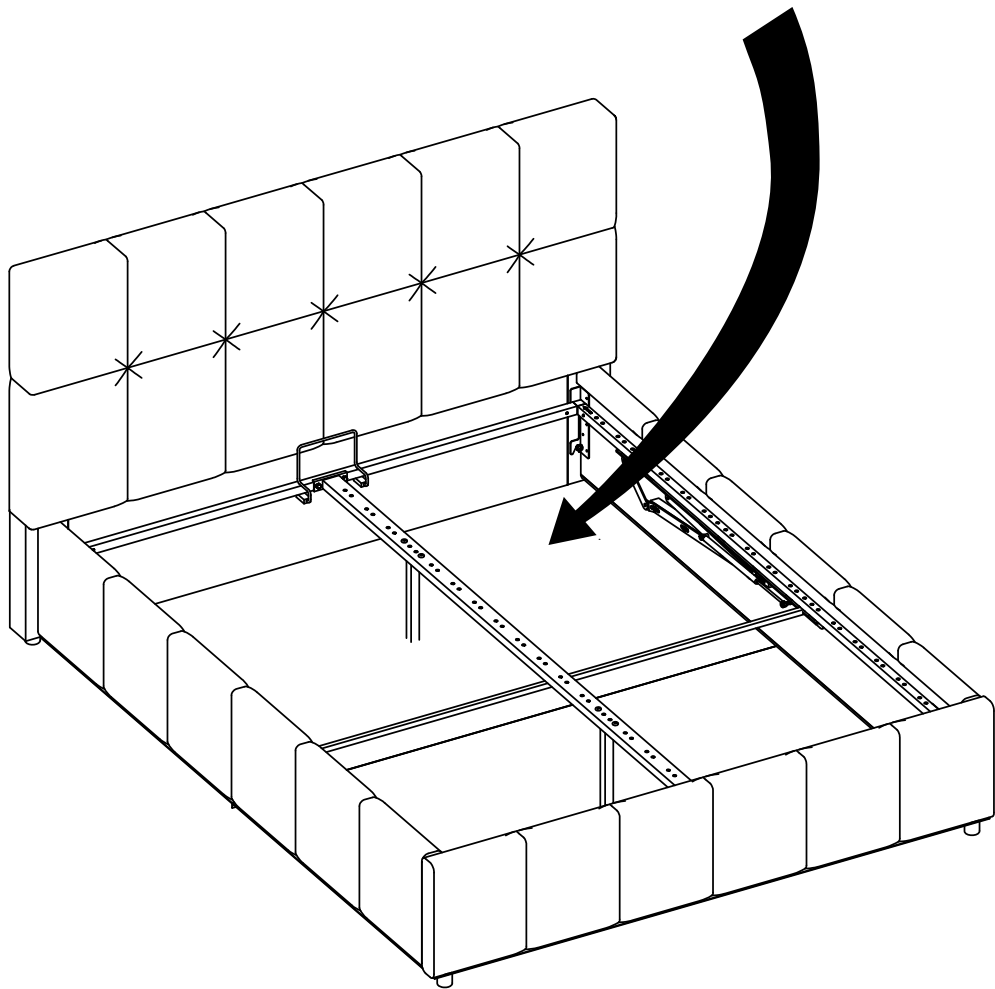
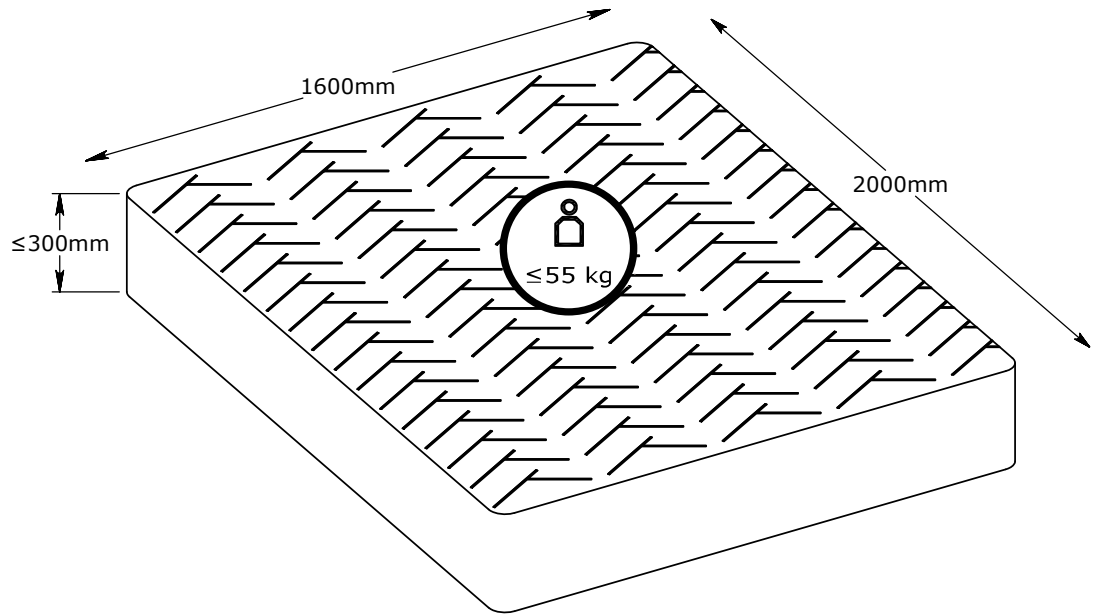

21

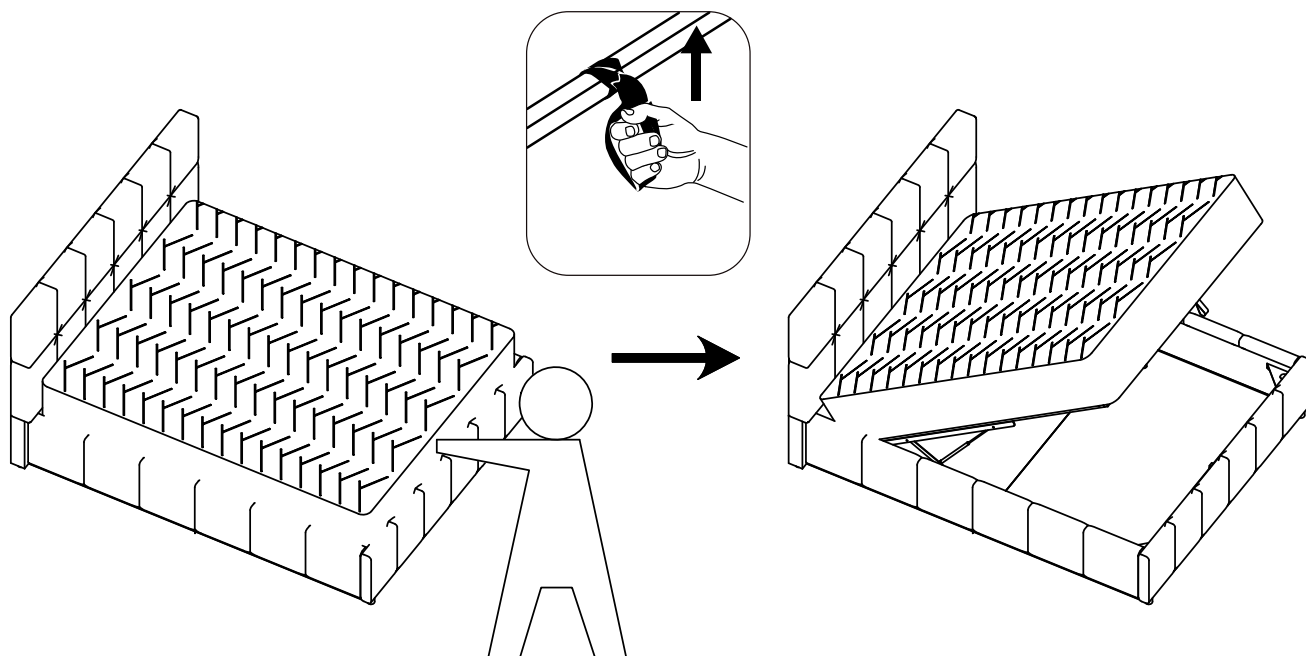
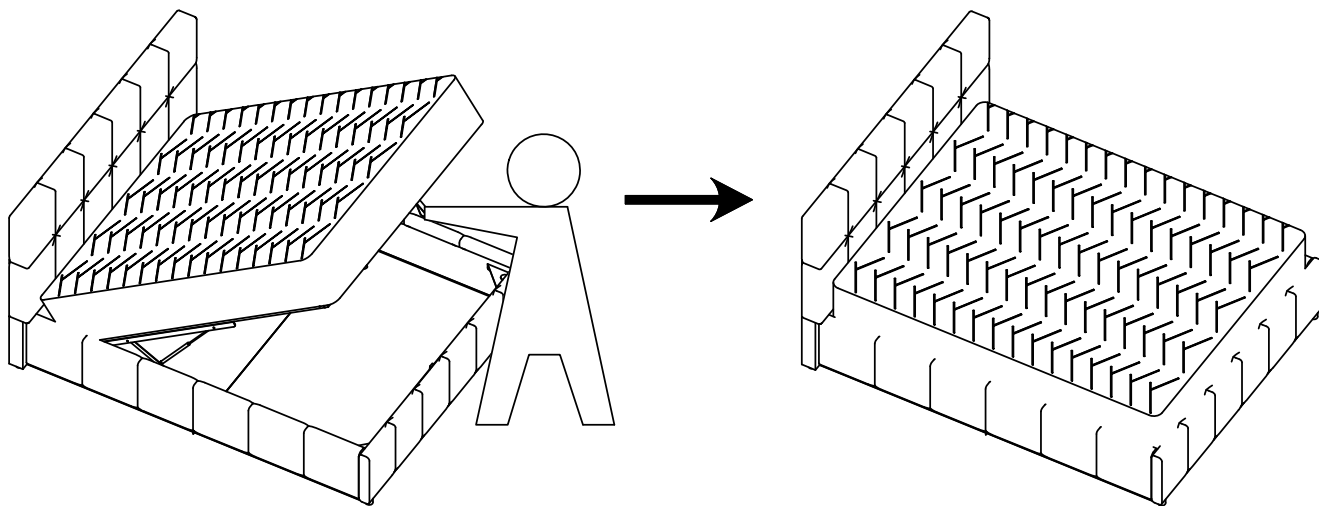

22

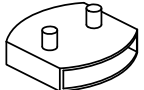
Q x 32  56x29x12mm	R x 16  56x50x12mm
---	---

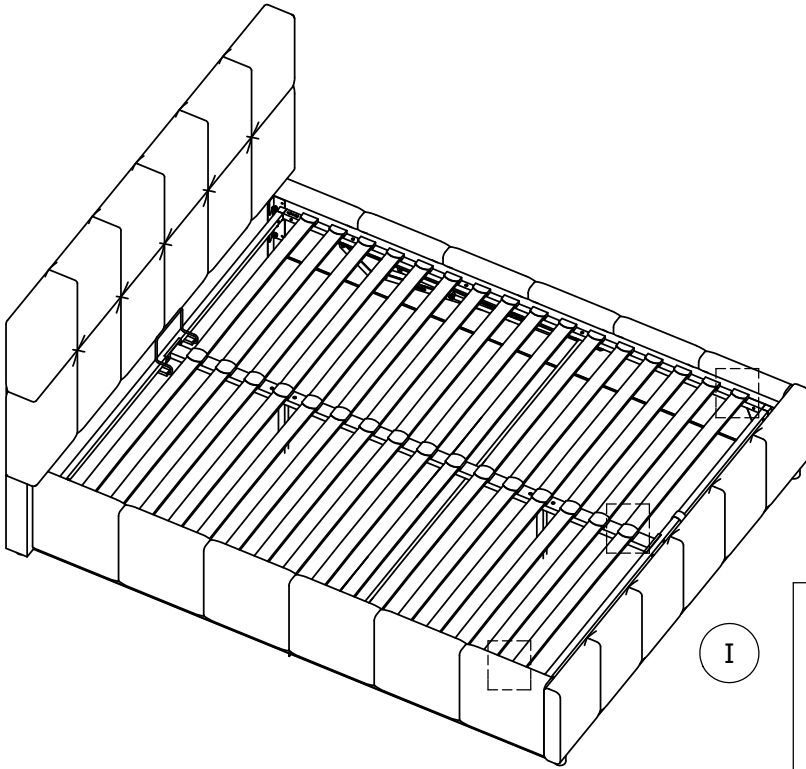
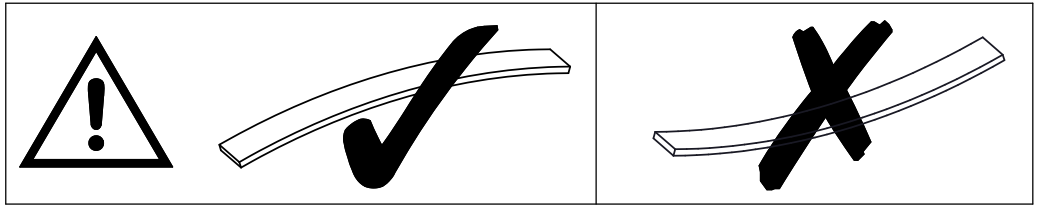

I

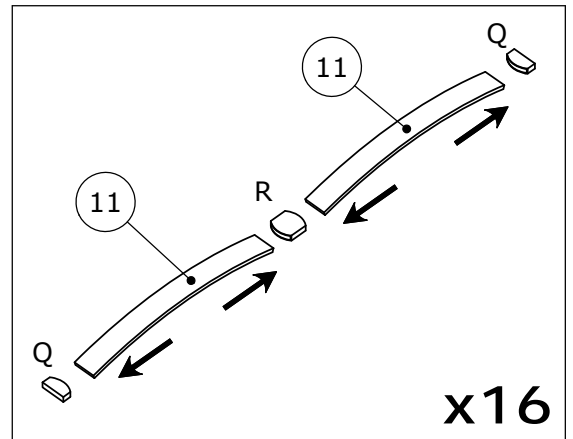

II

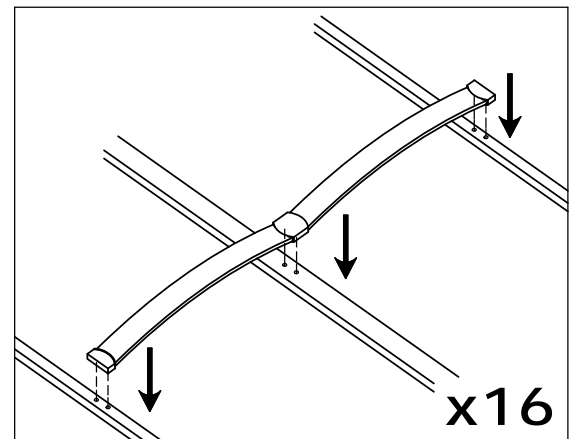

23

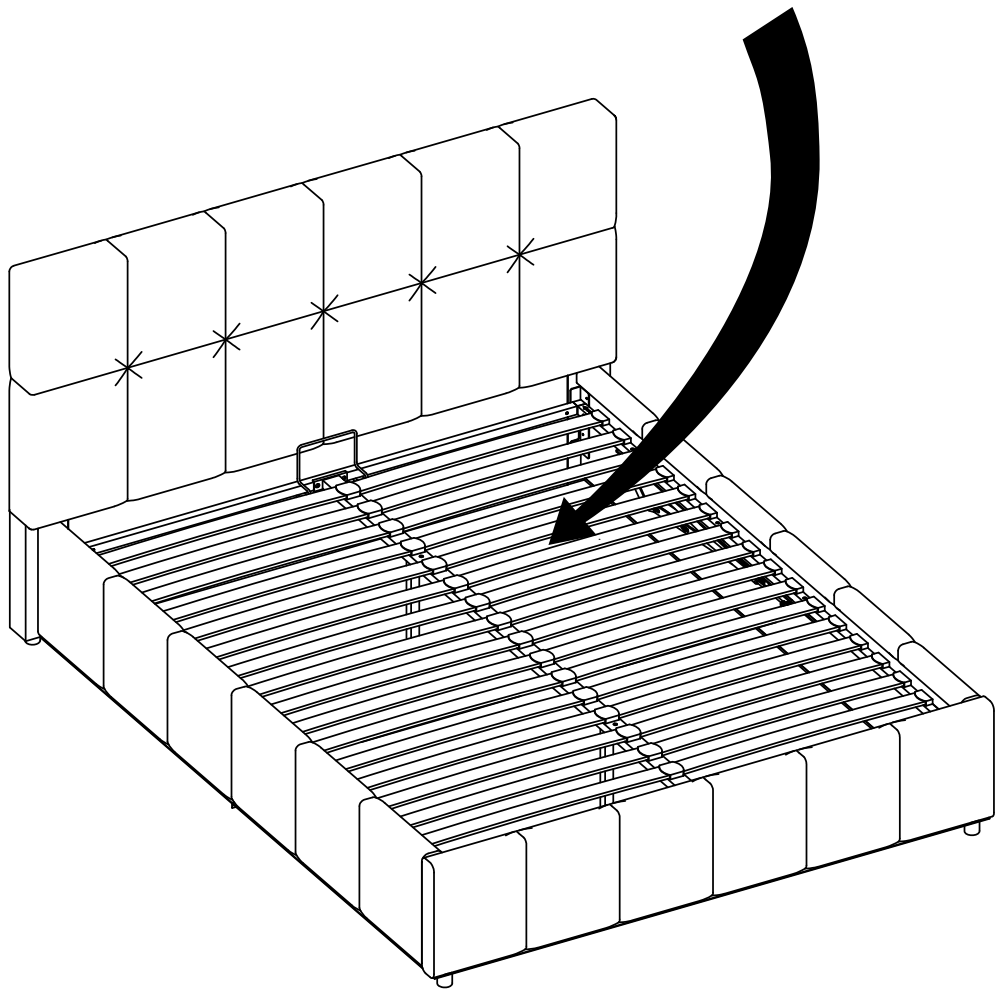
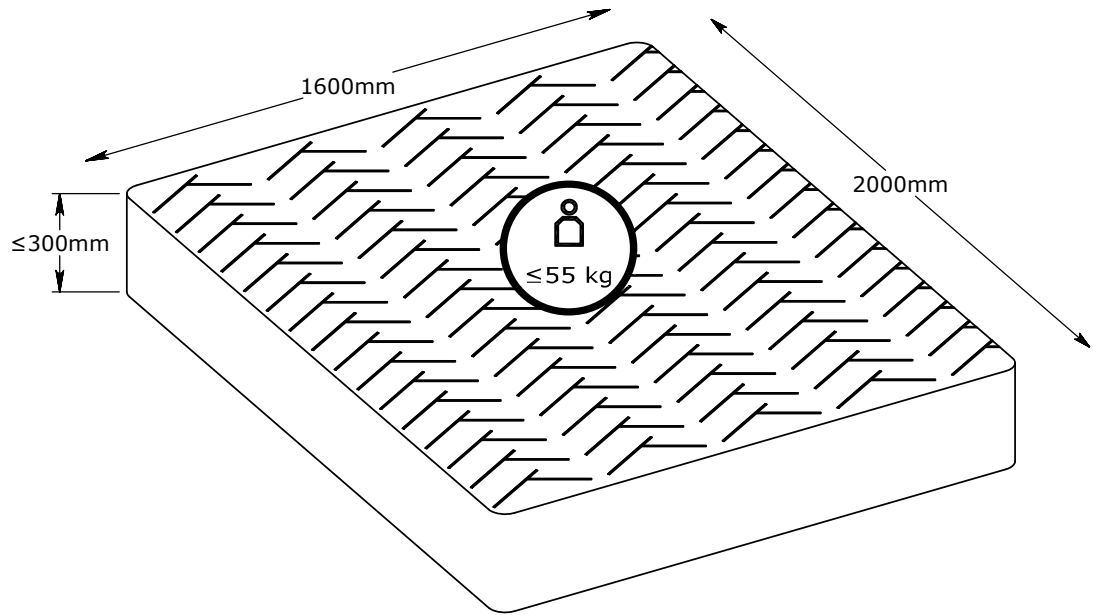

24

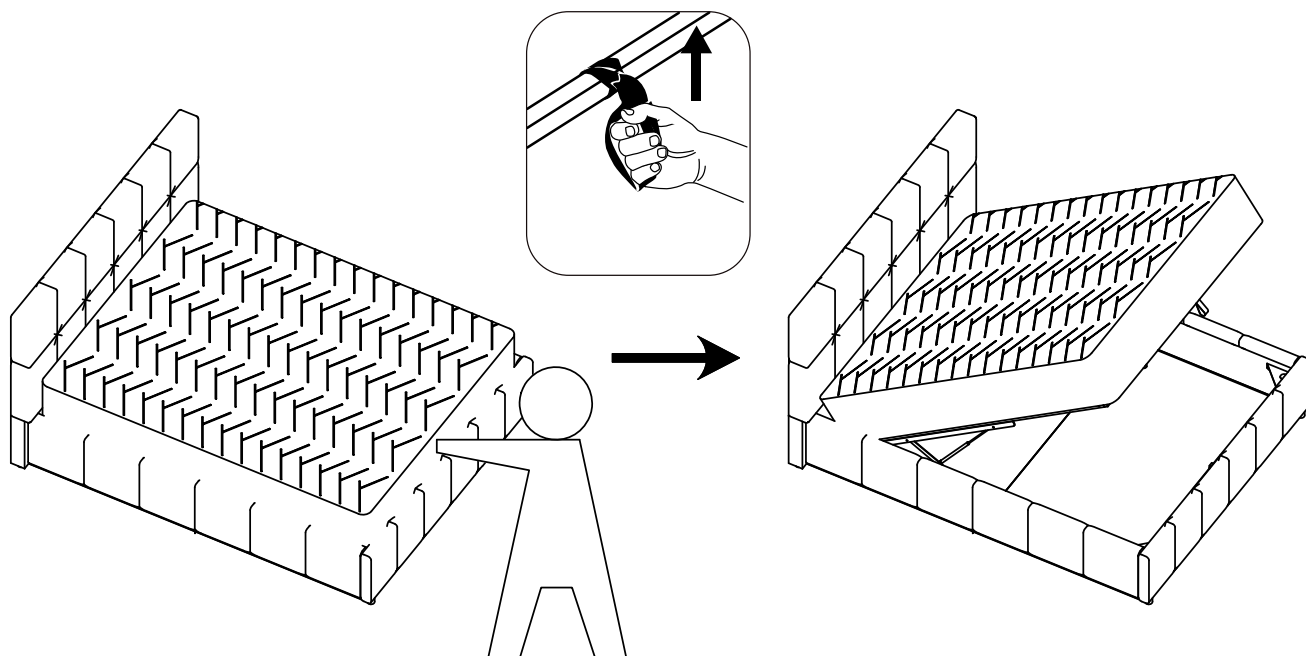
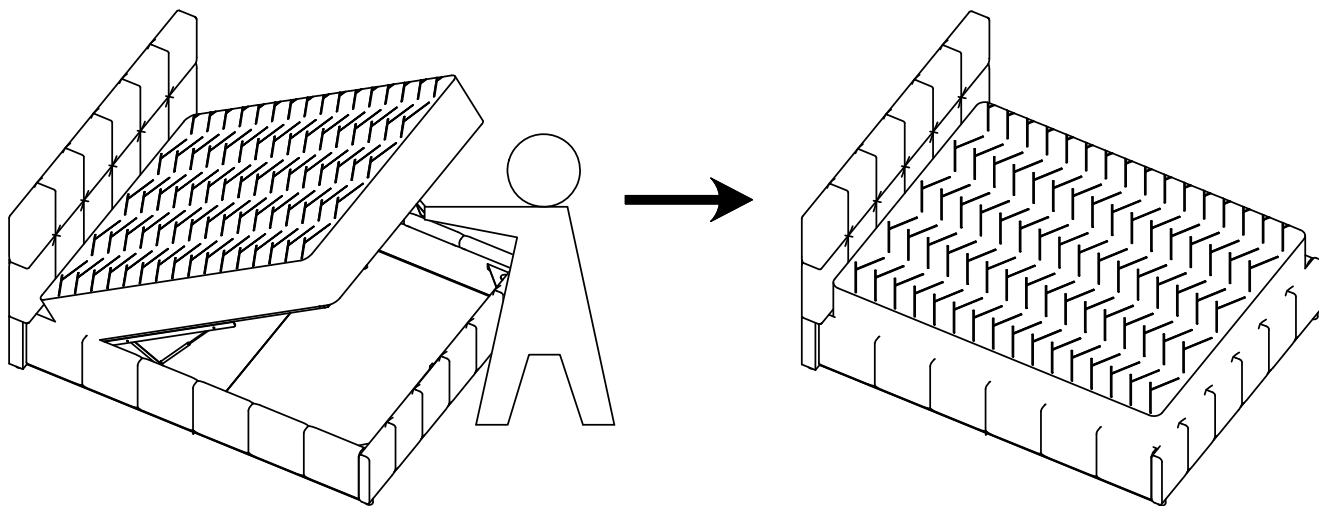

SIA "Do It",
Biķeru iela 4,
Ulbroka, Stopiņu
novads, LV-2130,
Latvija; info@doit.lv