

ALLESHAVE

137967/
720-256-1017

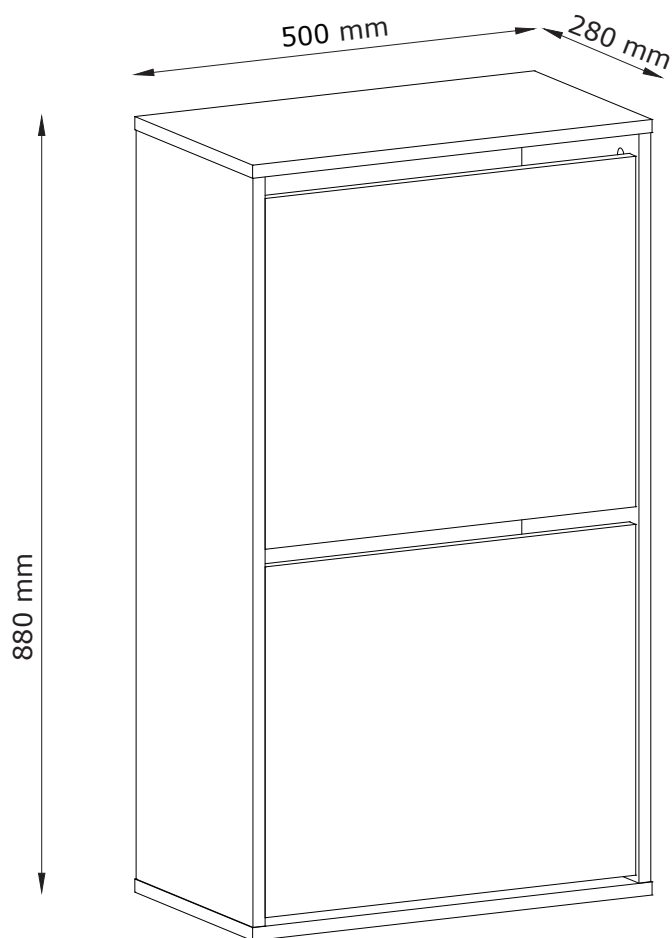

FR
Donnez ou recyclez
vos meubles.



Association

ou



Magasin

ou



Déchèterie

<https://quefairedemesdechets.fr>



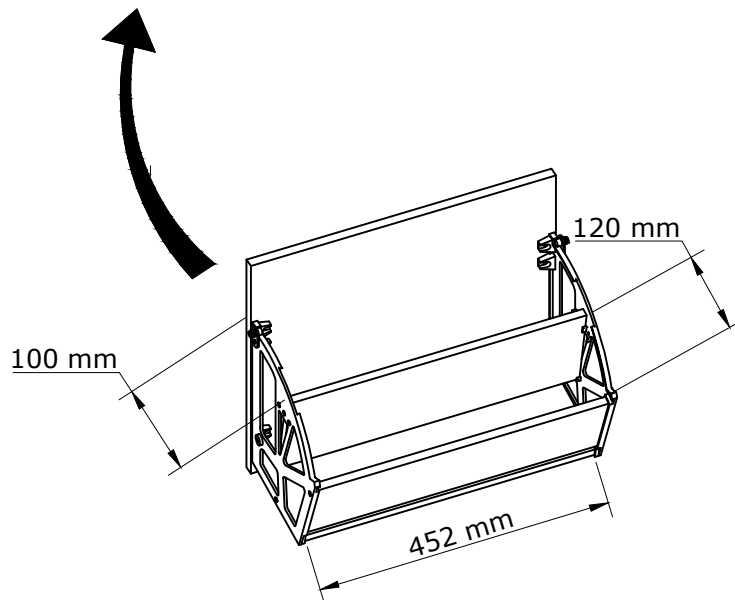
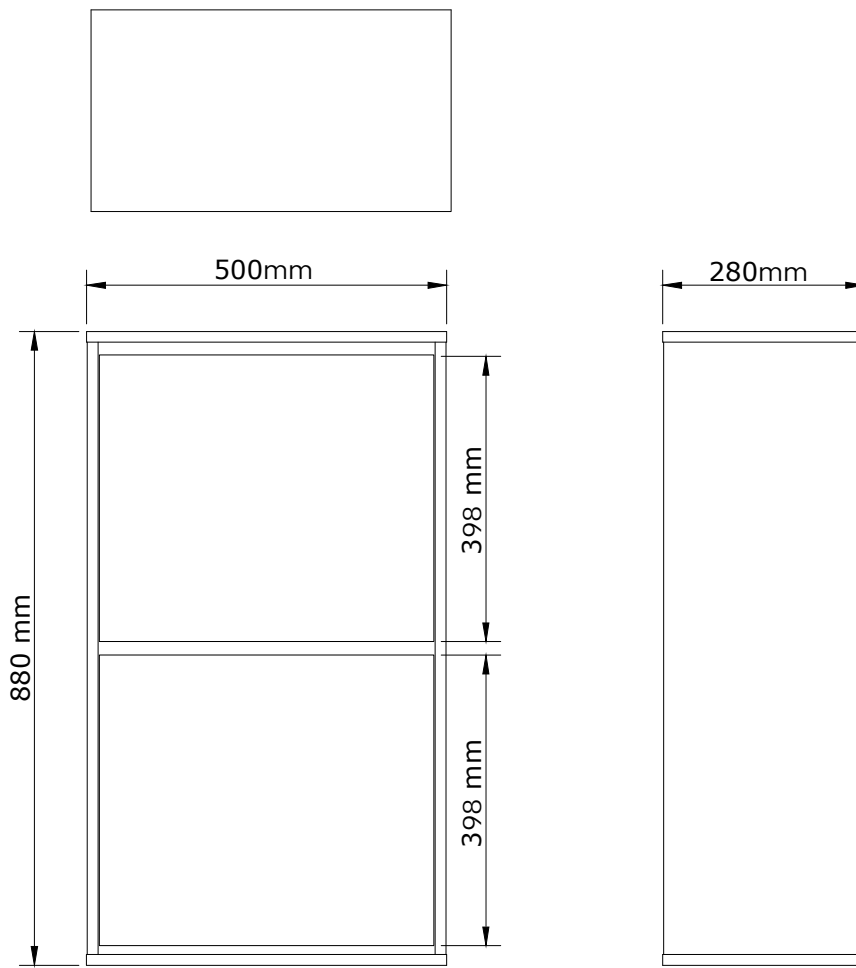



EN: IMPORTANT INFORMATION!

Please read the entire manual carefully before starting to assemble and/or using this product. Follow the manual thoroughly and keep it for further reference.

FR: INFORMATIONS IMPORTANTES

Veillez lire attentivement l'ensemble du manuel avant de commencer à monter et/ou utiliser ce produit. Suivez rigoureusement le manuel et conservez-le pour toute consultation ultérieure.

LV: SVARĪGA INFORMĀCIJA!

Pirms šī izstrādājuma montāžas un/vai lietošanas uzsākšanas pilnībā izlasiet lietošanas pamācību. Stingri ievērojiet pamācības norādījumus un saglabājiet to turpmākai lietošanai.

LT: SVARBI INFORMACIJA!

Prieš pradėdami montuoti gaminį ir (arba) juo naudotis, prašome atidžiai perskaityti visą vadovą. Atidžiai skaitykite vadovą ir turėkite jį su savimi, kad galėtumėte toliau vadovautis jo nuorodomis.

EE: OLULINE TEAVE!

Enne kui alustate toote kokku panemist ja/või kasutamist, lugege see kasutusjuhend hoolikalt läbi. Järgige täpselt juhendis toodud juhiseid ja hoidke juhend alles.

RU: ВАЖНАЯ ИНФОРМАЦИЯ!

Внимательно и полностью прочитайте это руководство, прежде чем приступать к сборке или использованию этого изделия. Следуйте всем инструкциям этого руководства и сохраните его на будущее для справки.



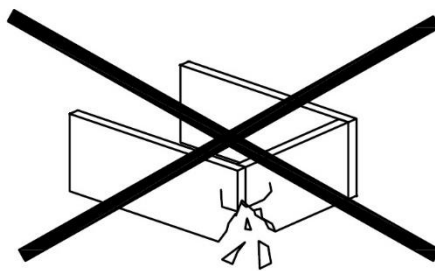

EN: WARNING TO AVOID SCRATCHES!

In order to avoid scratching this furniture should be assembled on a soft layer - could be a rug.

FR: AVERTISSEMENT POUR ÉVITER LES RAYURES

Afin d'éviter les rayures, ce meuble doit être monté sur une surface souple (un tapis, par exemple).

LV: BRĪDINĀJUMS PAR SKRĀPĒJUMIEM!

Lai nesaskrāpētu šo izstrādājumu, veiciet montāžu uz mīkstas pamatnes, piemēram, paklāja.

LT: ĮSPĖJIMAS, KAD IŠVENGTUMĖTE ĮBRĖŽIMŲ!

Šio baldo nesubraižysite, jei jį surinksite ant švelnaus paviršiaus, pavyzdžiui, kilimo.

EE: HOIATUS KRIIMUSTUSTE VÄLTIMISEKS!

Kriimustuste tekkimise vältimiseks mööblile tuleb see kokku panna pehmel pinnal, nt kaltsuvaibal.

RU: ПРЕДУПРЕЖДЕНИЕ ОТНОСИТЕЛЬНО ЦАРАПИН!

Во избежание нанесения царапин, сборку этой мебели необходимо выполнять на мягкой поверхности, например на ковре.





EN: IMPORTANT!

Mounting screws are not included.

Always make sure that the fastening method you choose is suitable and safe for your home.

FR: IMPORTANT

Les vis de montage ne sont pas fournies.

Assurez-vous toujours que la méthode de montage que vous choisirez convienne à votre domicile et soit sûre.

LV: SVARĪGI!

Montāžas skrūves nav iekļautas komplektācijā.

Vienmēr pārliecinieties, ka jūsu izvēlētajā stiprināšanas metode ir piemērota un droša jūsu mājoklim.

LT: SVARBU!

Tvirtinimo varžtai prie gaminio nėra pridėti.

Pagalvokite, ar pasirinktas tvirtinimo būdas yra tinkamas Jūsų namams ir yra saugus.

EE: TÄHTIS!

Kinnituskruid ei kuulu komplekti.

Alati veenduge, et teie valitud kinnitusmeetod on teie kodu jaoks sobiv ja ohutu.

RU: ВАЖНО!

Крепежные шурупы не входят в комплект.

Обязательно убедитесь, что выбранный способ крепления является допустимым и безопасным для вашего дома.

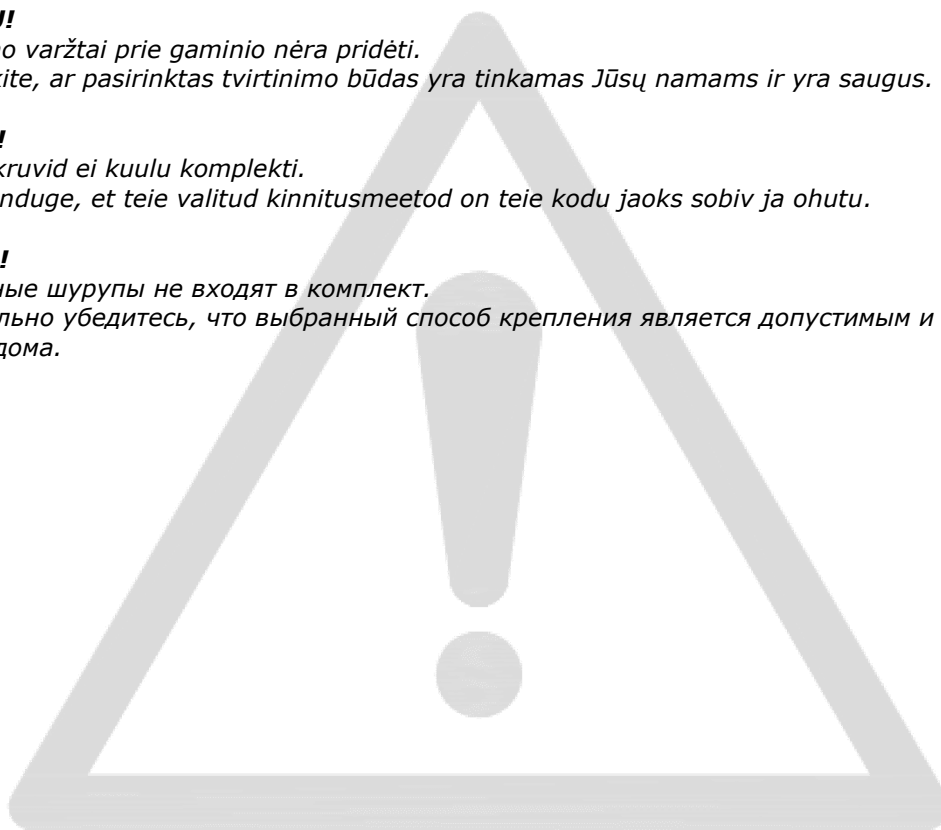

EN: IMPORTANT!

It is important that any product which is assembled using any kind of screw is re-tightened 2 weeks after assembly, and once every 3 months - in order to assure stability through-out the lifespan of the product.

FR: IMPORTANT

Il est important que tout produit monté à l'aide de vis soit resserré 2 semaines après son montage, puis tous les 3 mois, afin de garantir sa stabilité durant tout son cycle de vie.

LV: SVARĪGI!

Ir svarīgi, lai jebkuram produktam, kas tiek uzstādīts ar jebkādu skrūvju palīdzību, skrūves tiktu atkārtoti pievilktas 2 nedēļas pēc montāžas, pēc tam – reizi 3 mēnešos, tā nodrošinot stabilitāti visā izstrādājuma kalpošanas laikā.

LT: SVARBU!

Bet kokį varžtais tvirtinamą gaminį 2 savaites po surinkimo bei kas 3 mėnesius reikia papildomai suveržti – taip užtikrinamas naudojamo gaminio stabilumas.

EE: TÄHTIS!

Oluline on, et toote kruvisid pingutataks 2 nädalat pärast kokkupanekut ja seejärel iga 3 kuu järel, et tagada stabiilsus kogu toote eluea jooksul.

RU: ВАЖНО!

В любом изделии, собранном с использованием винтов любого типа, необходимо через 2 недели после сборки и в дальнейшем каждые 3 месяца подтягивать винты, чтобы обеспечить прочность изделия в течение срока эксплуатации.





EN: GENERAL INSTRUCTION FOR FURNITURE SURFACES!

*Wipe clean with a damp cloth. Use only water or a gentle detergent.
Wipe dry with a clean cloth.*

FR: INSTRUCTIONS GÉNÉRALES POUR LE MOBILIER

*Nettoyer à l'aide d'un chiffon humide. Utiliser uniquement de l'eau ou un détergent doux.
Essuyer à l'aide d'un chiffon propre.*

LV: VISPĀRĪGI KOPŠANAS NORĀDĪJUMI MĒBEĻU VIRSMĀM!

*Noslaukiet ar mitru drānu. Lietojiet tikai ūdeni vai maigu mazgāšanas līdzekli.
Nosusiniet ar tīru drānu.*

LT: BENDRIEJI NURODYMAI DĖL BALDŲ PAVIRŠIŲ!

*Valykite drėgnu skudurėliu. Naudokite tik vandenį arba švelnų valiklį.
Nusausinkite švarių skudurėliu.*

EE: ÜLDISED JUHISED MÖÖBLIPINDADE JAOKS!

*Kasutage puhastamiseks niisket lappi. Kasutage ainult vett või õrnatoimelist puhastusvahendit.
Pühkige puhta lapiga kuivaks.*

RU: ОБЩИЕ ПРАВИЛА ЭКСПЛУАТАЦИИ МЕБЕЛЬНЫХ ПОВЕРХНОСТЕЙ!

*Очистите изделие чистой влажной тканью. Используйте мягкодействующее моющее средство.
Вытрите досуха чистой тряпкой.*

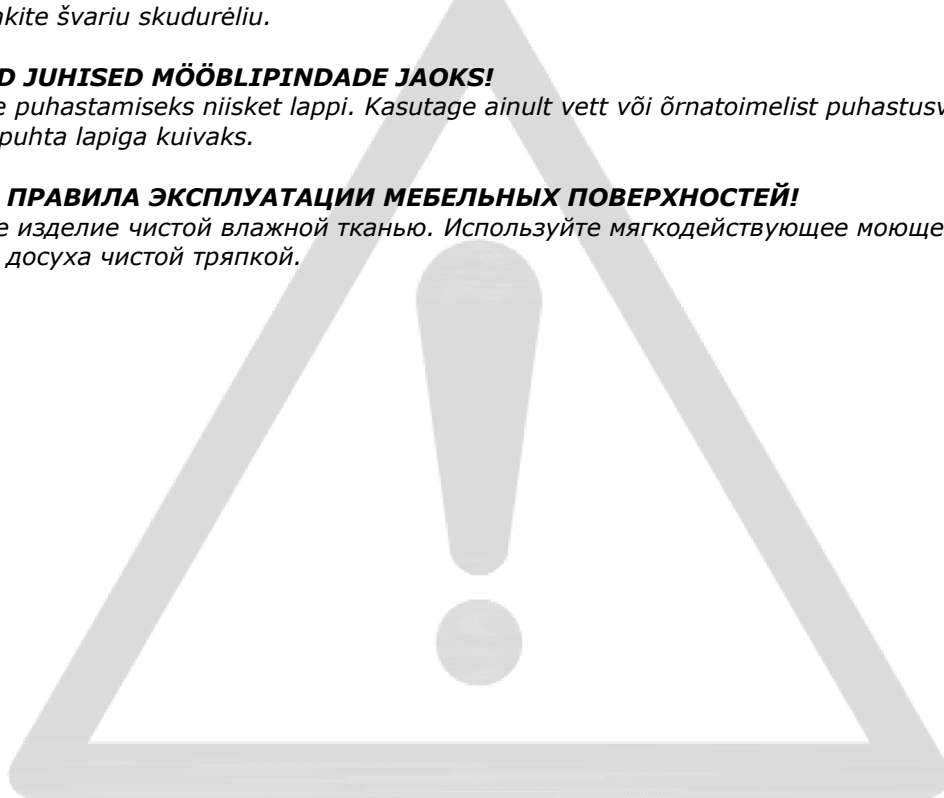

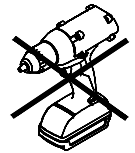
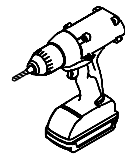
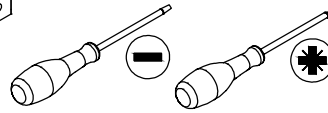
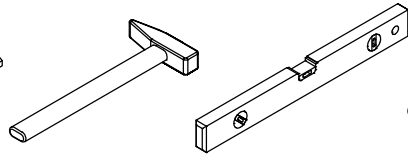
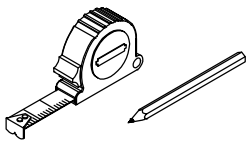

A x 16



Ø15x11,5 mm

B x 16

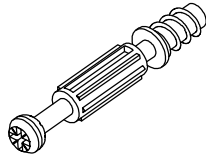

Ø7,5x41 mm

C x 10

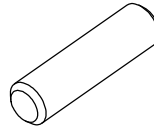

Ø8x30 mm

D x 12

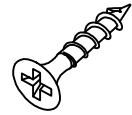

Ø3,5x20 mm

E x 2

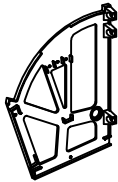

260 x 212 mm

F x 2

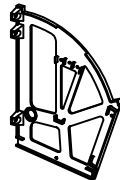

260 x 212 mm

G x 4



Ø20x15 mm

H x 4

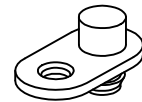

34 x 18 mm

J x 16

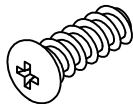

Ø6x15 mm

K x 4



Ø6x9 mm

L x 8

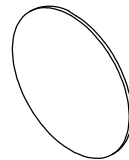

Ø21 mm

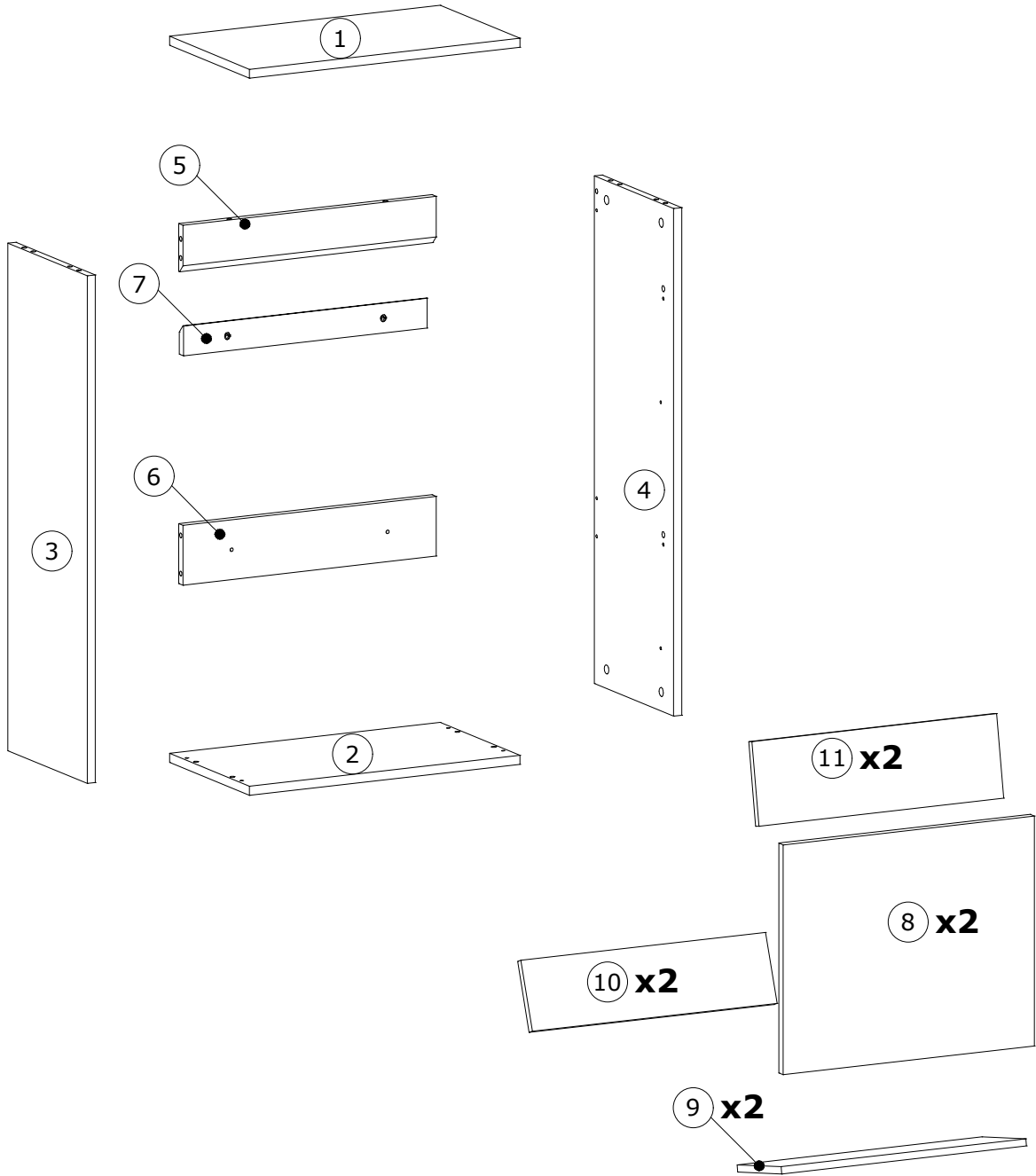

Box 1/1:

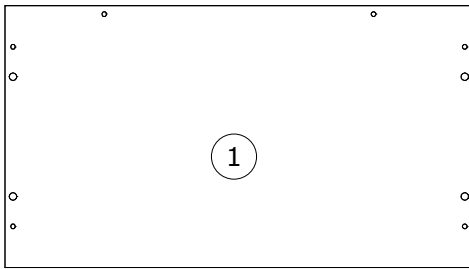

500 x 280 x 15 mm

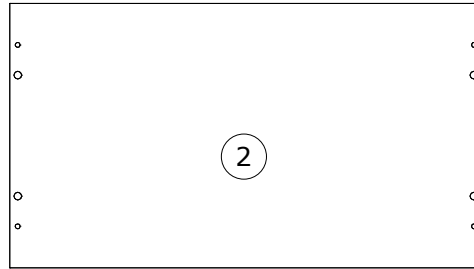

500 x 280 x 15 mm

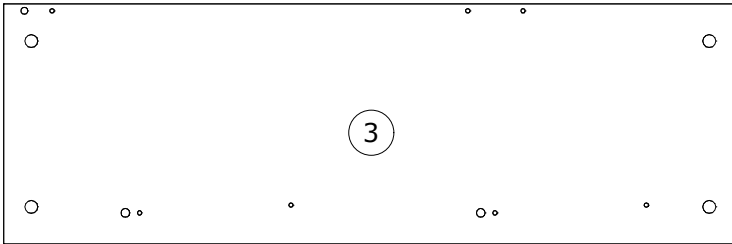

850 x 278 x 15 mm

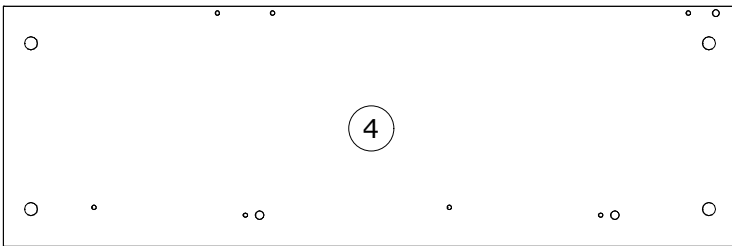

850 x 278 x 15 mm

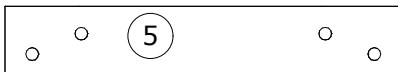

468 x 80 x 15 mm

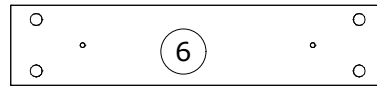

468 x 100 x 15 mm

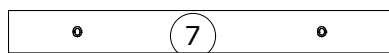

450 x 50 x 15 mm

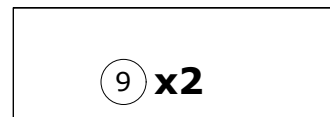

452 x 157 x 12 mm

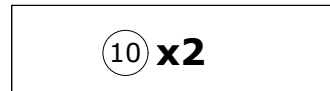

452 x 118 x 12 mm

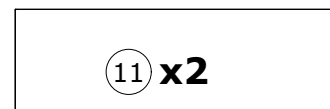

452 x 136 x 12 mm

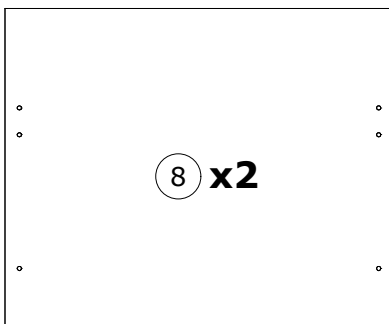

462 x 398 x 15 mm

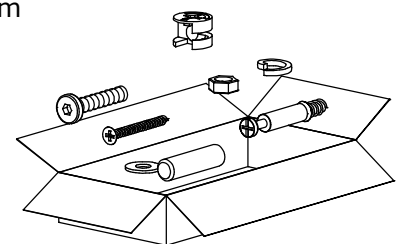

1

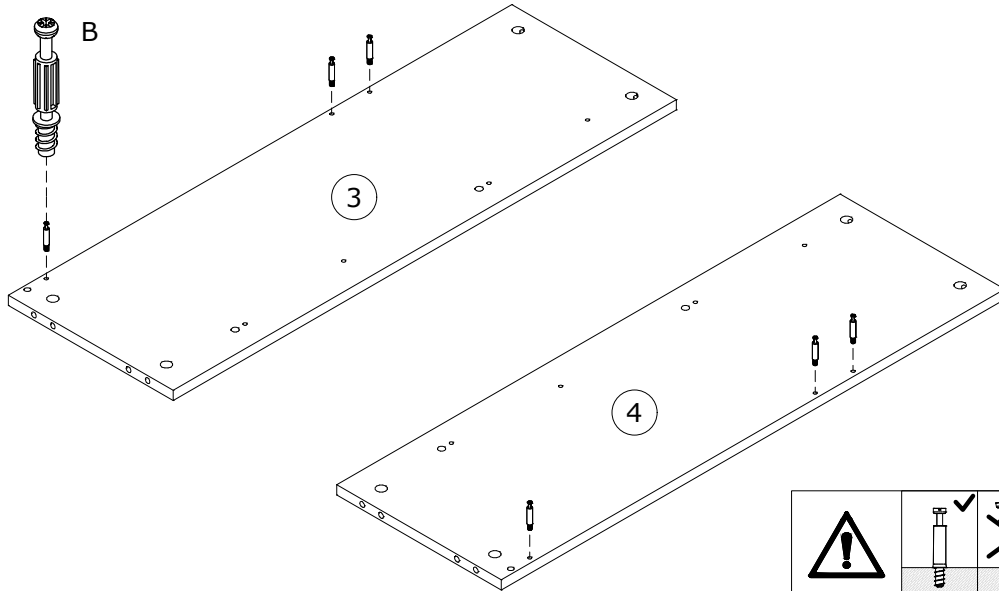
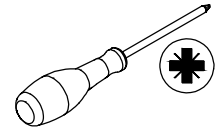
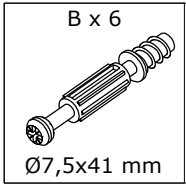

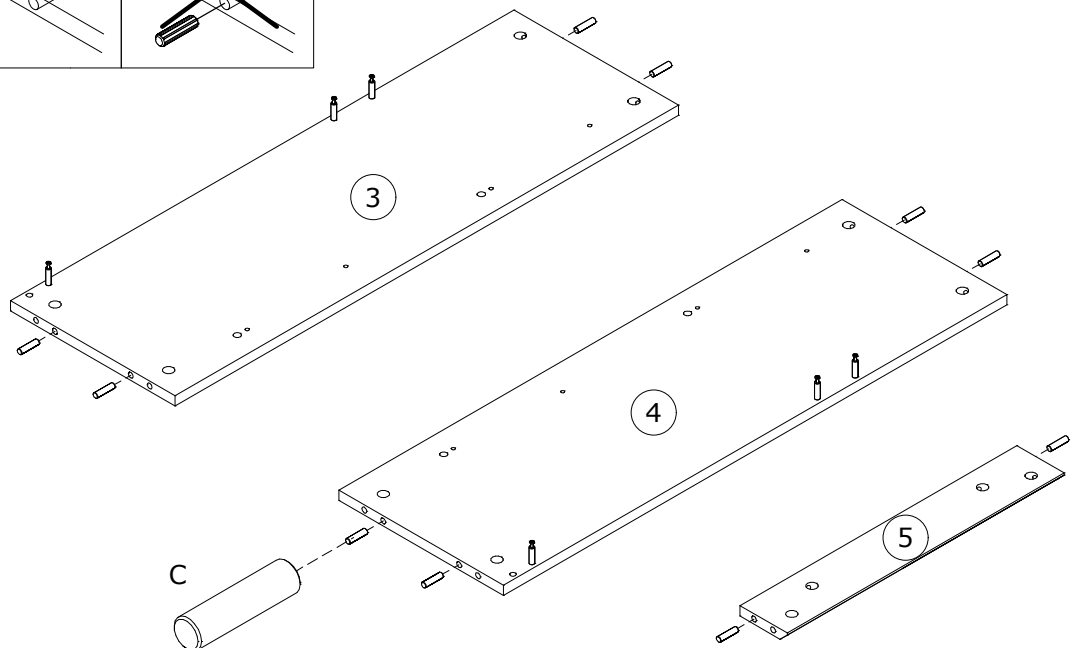
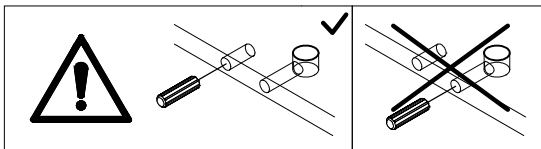
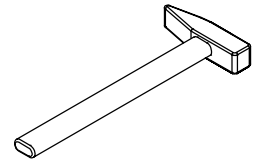
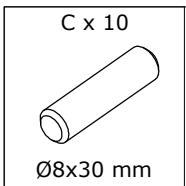

2



3

| | | |
|--|---|--|
| H x 4  34 x 18 mm | K x 4  Ø6x9 mm |   |
|--|---|--|

| | | |
|---|---|--|
|  | K  Ø6x9 mm | J  Ø6x15 mm |
|---|---|--|

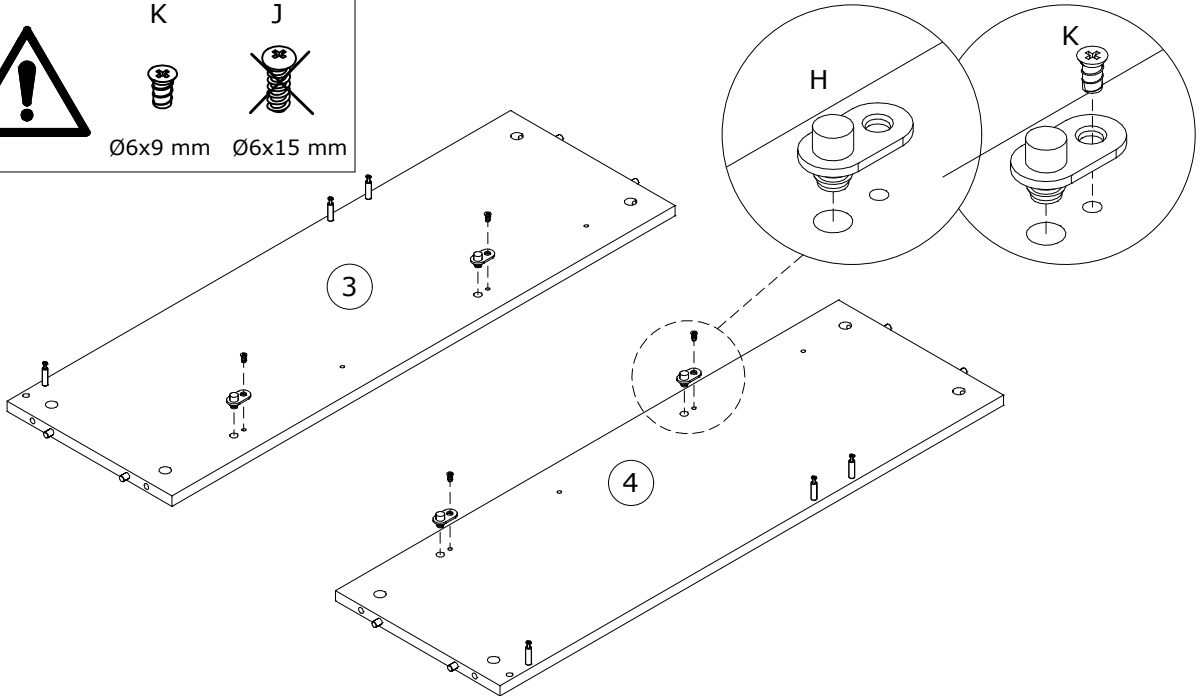

4

| | |
|---|---|
| A x 3  Ø15x11,5 mm |  |
|---|---|

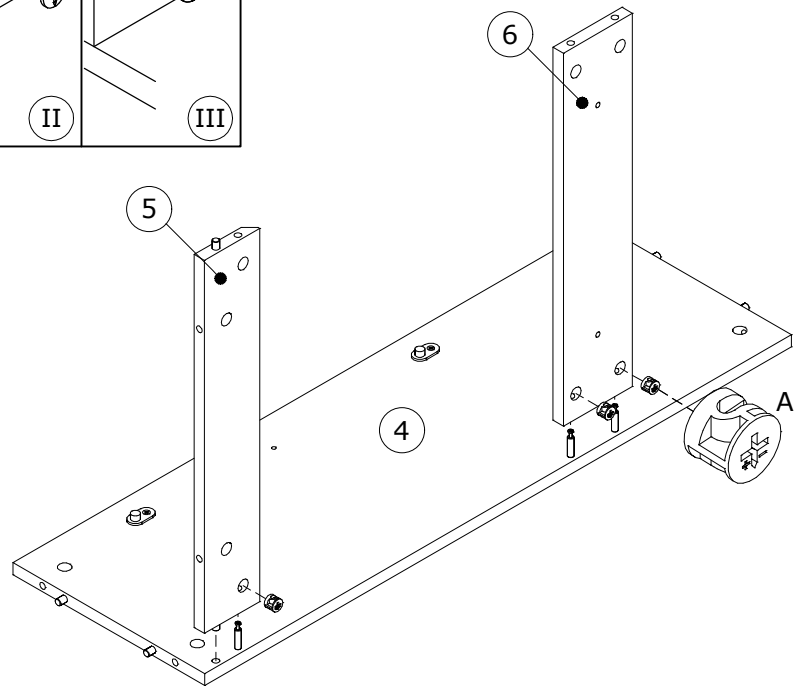
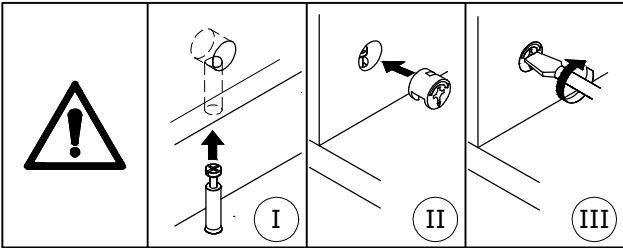

5

A x 3



Ø15x11,5 mm

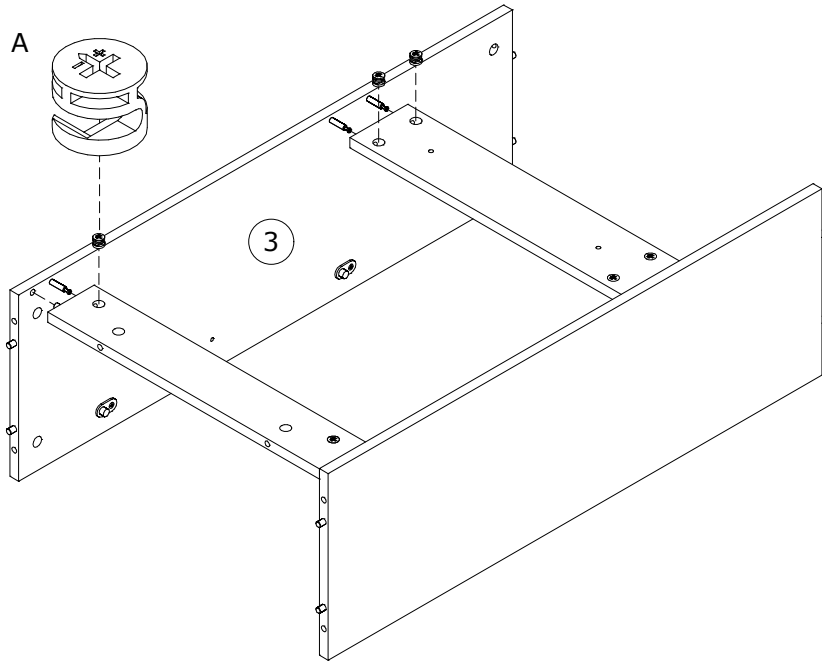

6

B x 10



Ø7,5x41 mm

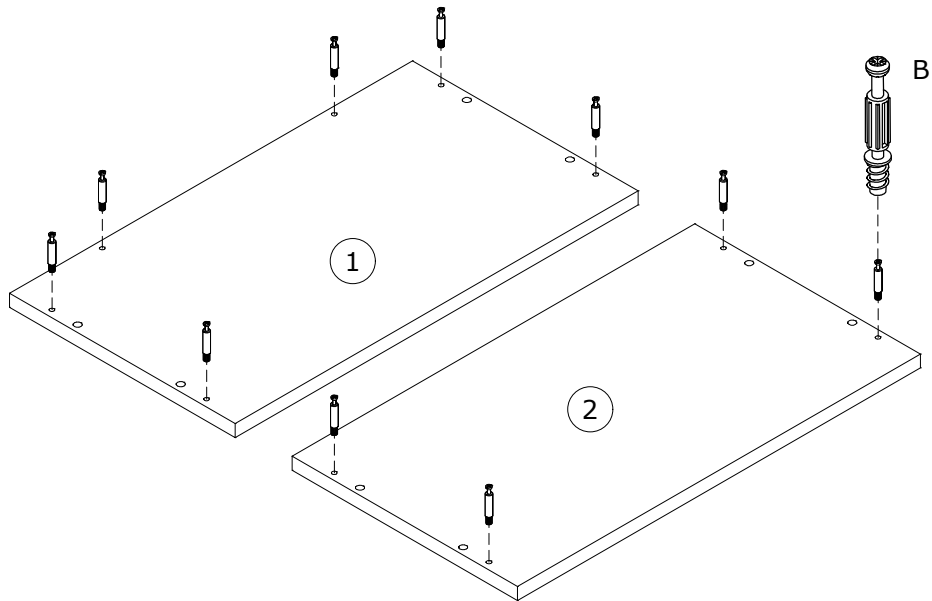

7

A x 6



Ø15x11,5 mm

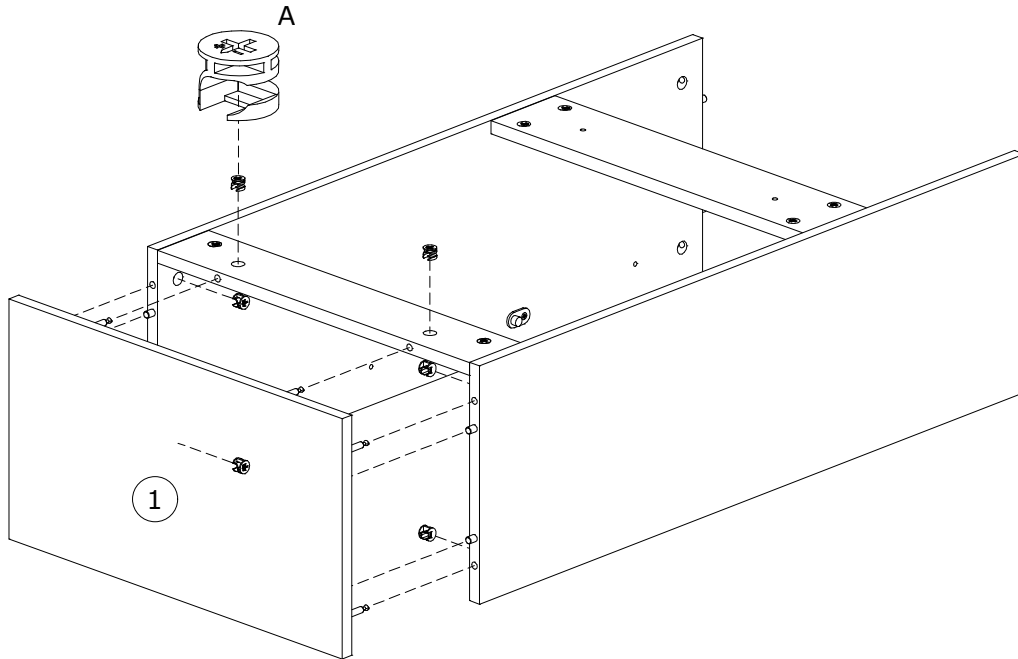

8

A x 4



Ø15x11,5 mm

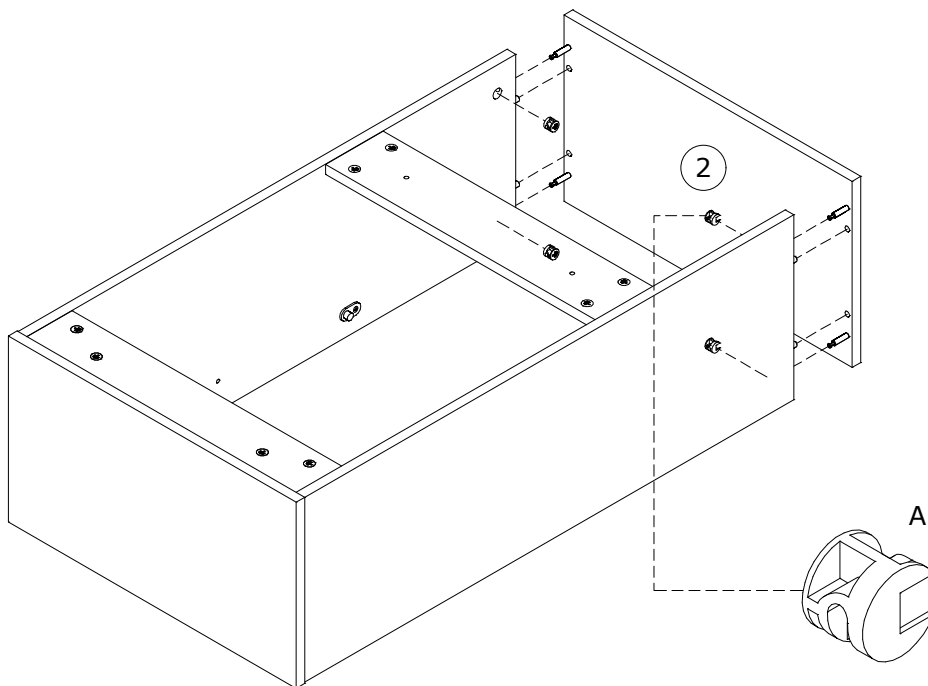

9

| | |
|---|--|
| L x 8 | |
|  | |
| Ø21 mm | |

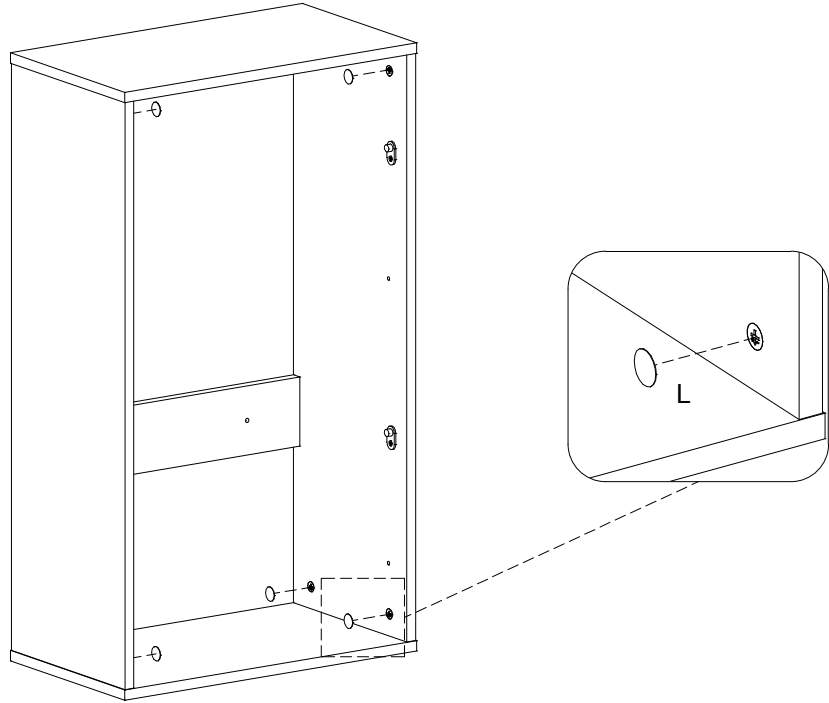

10

| | | | |
|---|---|---|---|
| E x 2 | F x 2 | J x 12 | |
|  |  |  |  |
| 260 x 212 mm | 260 x 212 mm | Ø6x15 mm | |

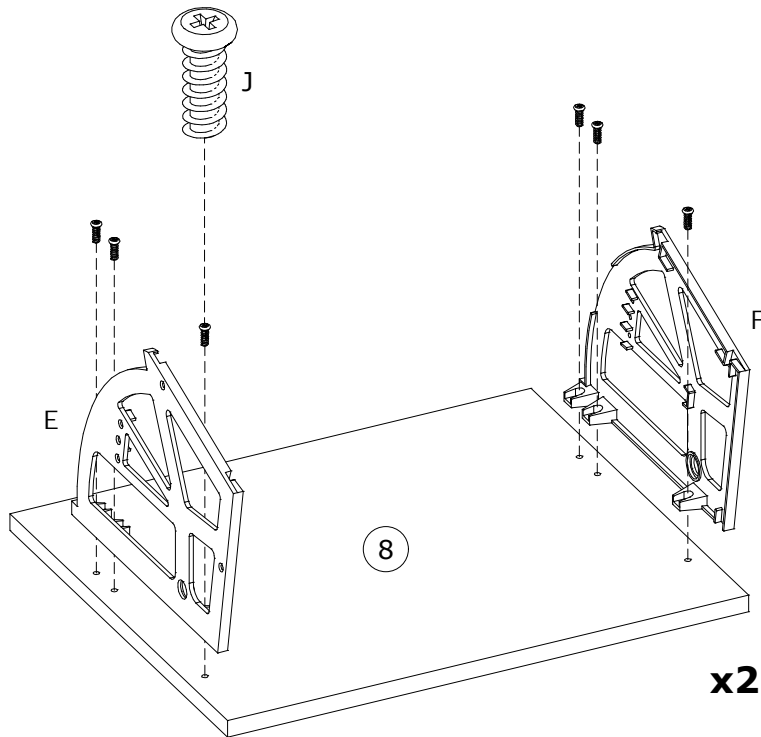

11

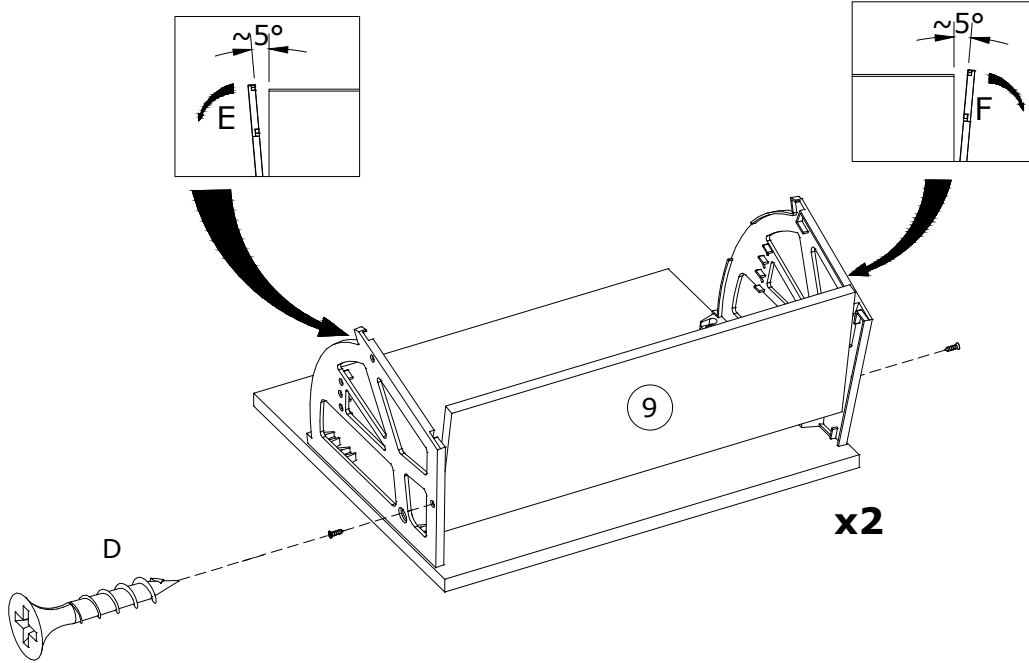

12

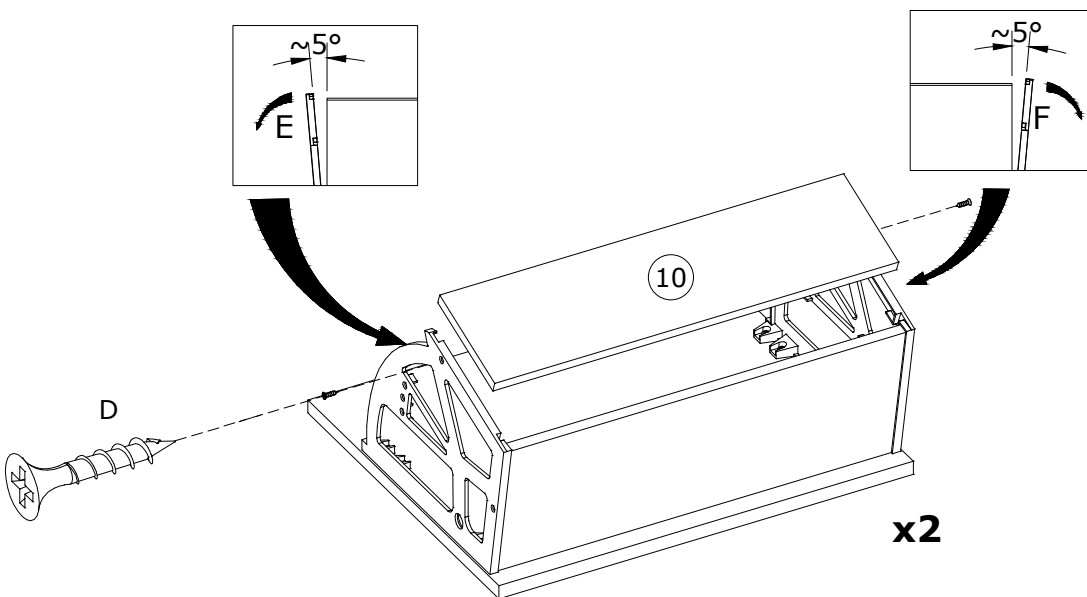

13

| | | |
|--|--|---|
| <p>G x 4</p>  <p>Ø15x9,5 mm</p> | <p>J x 4</p>  <p>Ø6x15 mm</p> |  |
|--|--|---|

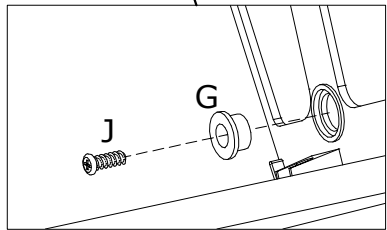
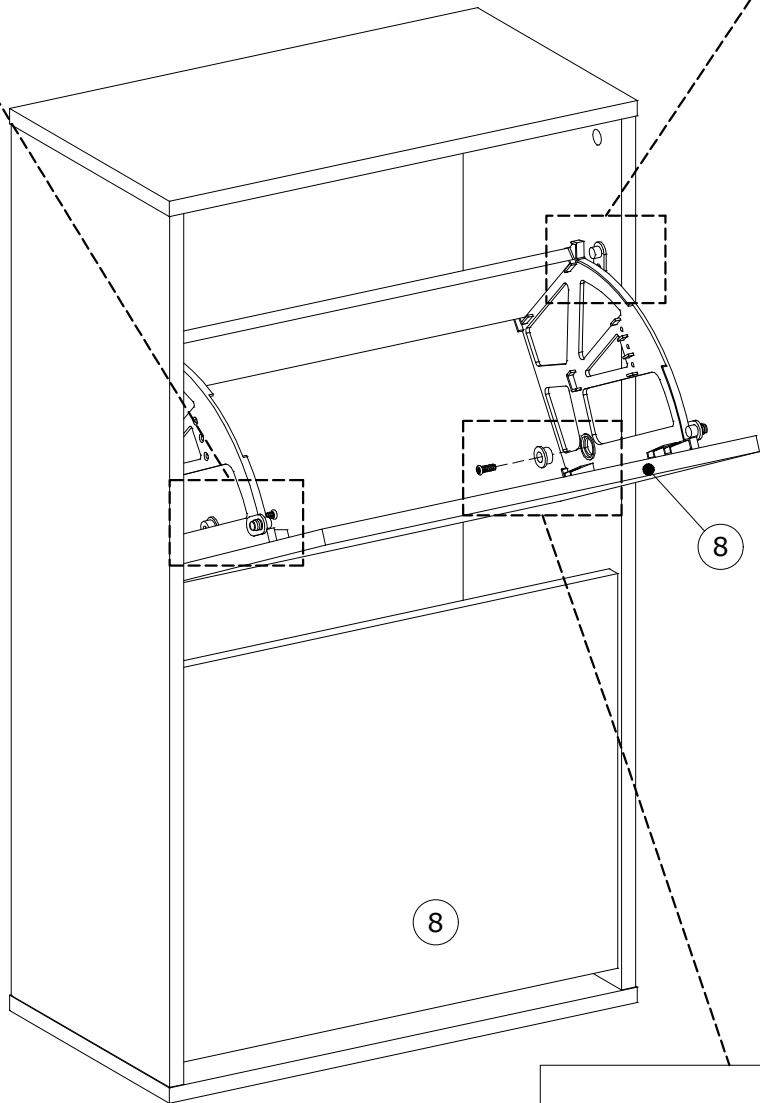
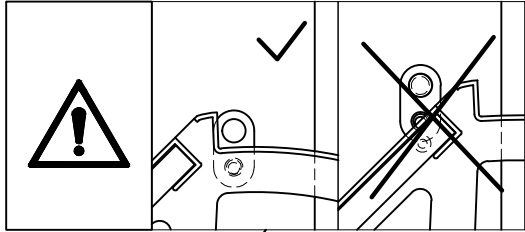
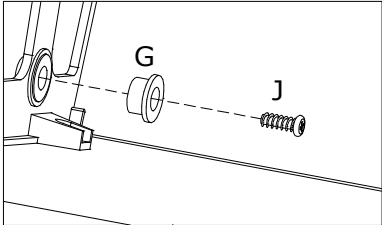

14

D x 4



Ø3,5x20 mm

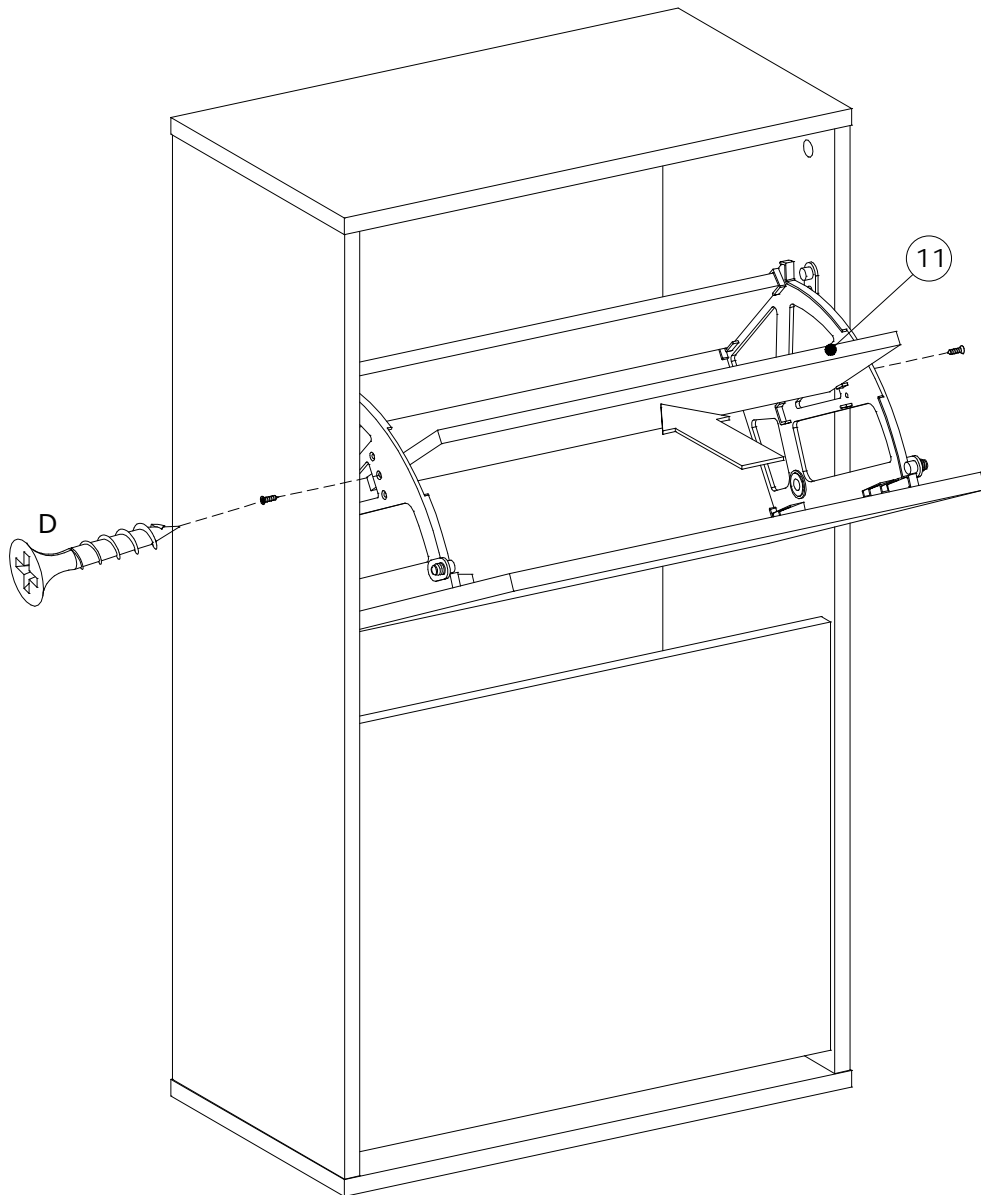
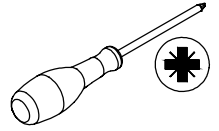

15

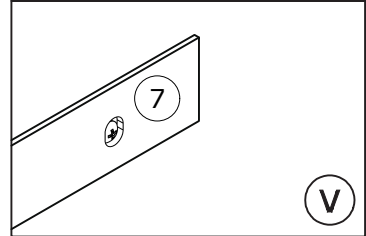
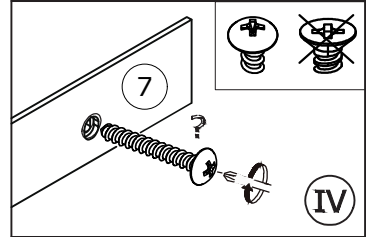
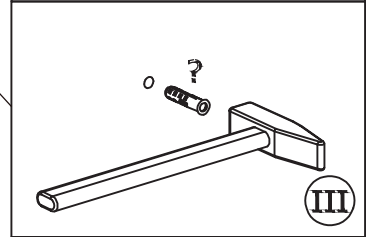
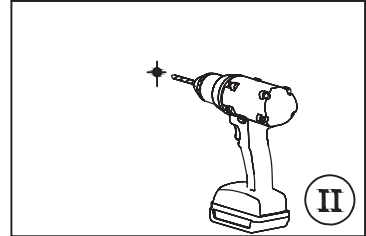
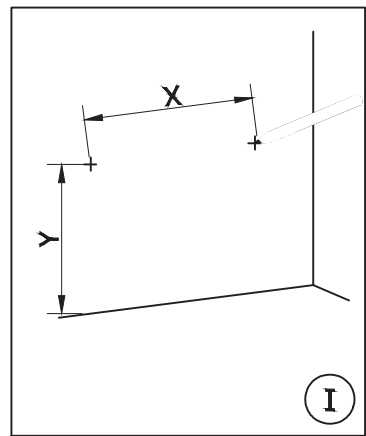
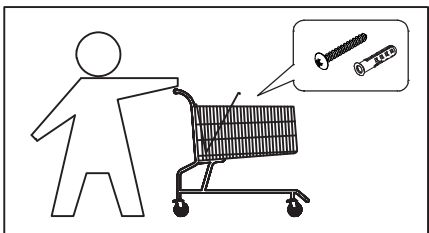
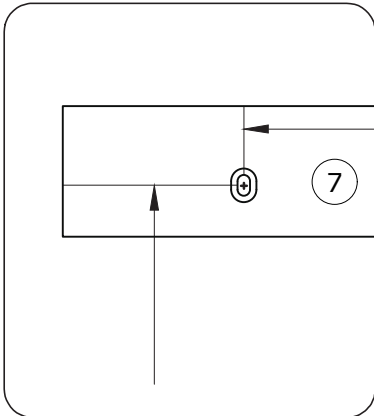
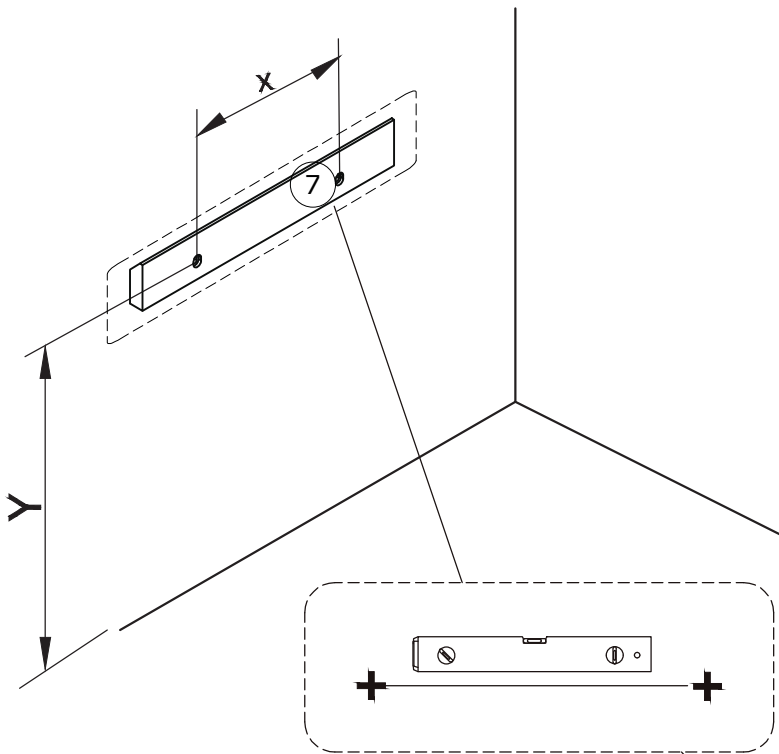
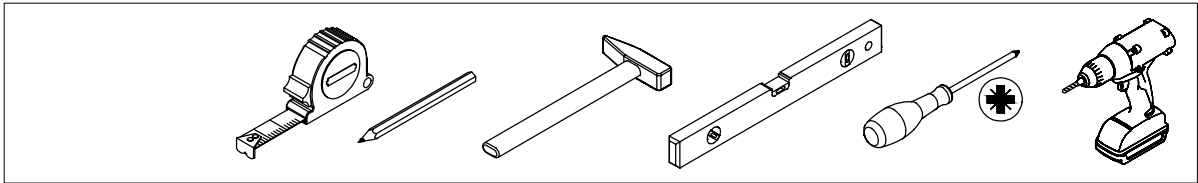

16

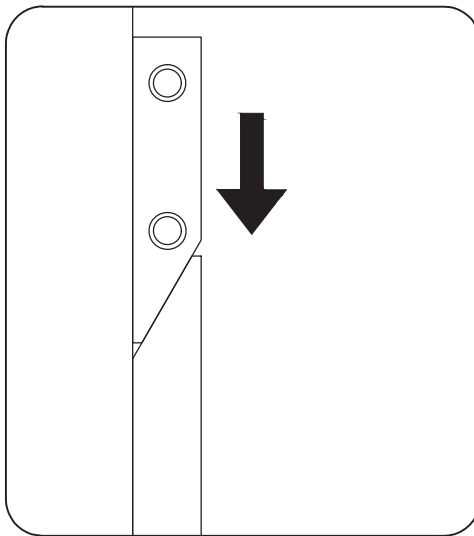
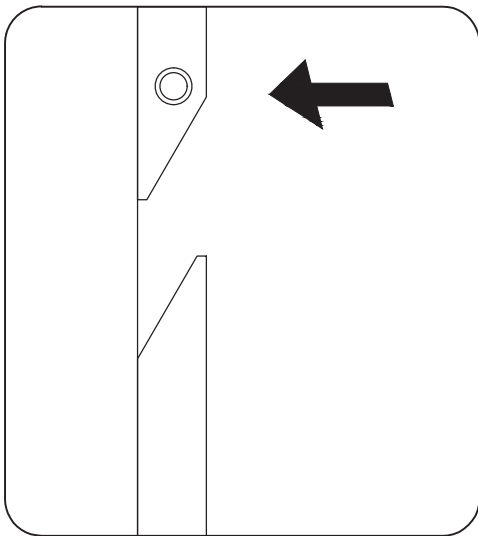
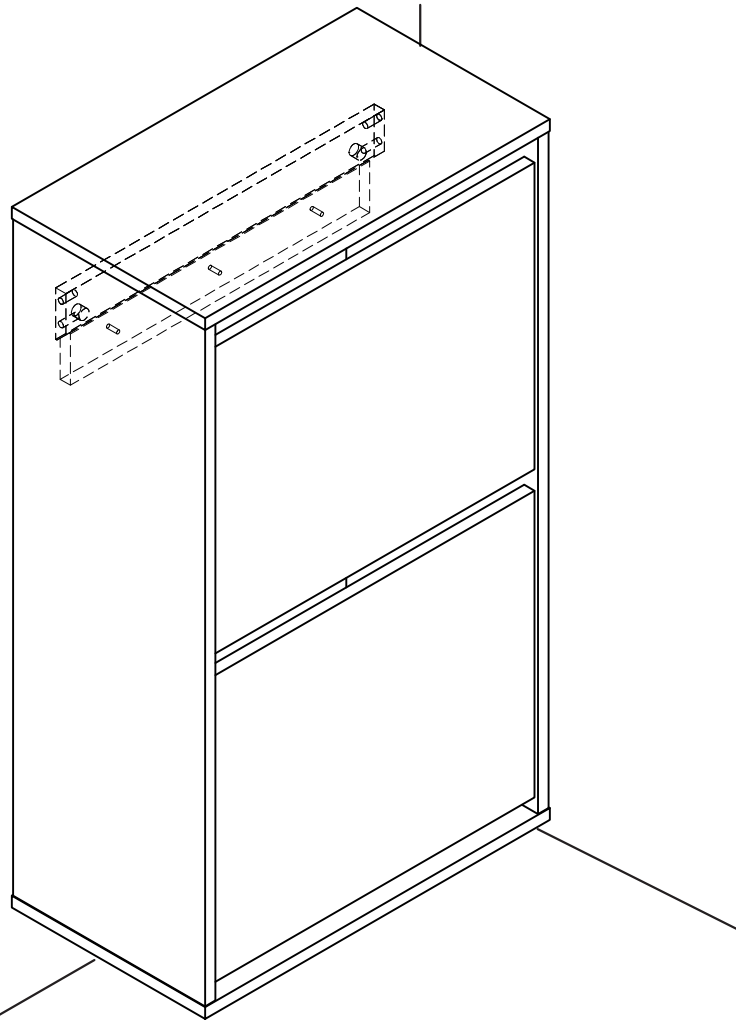

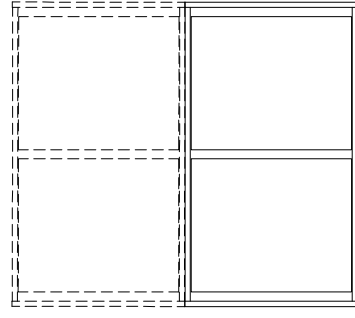
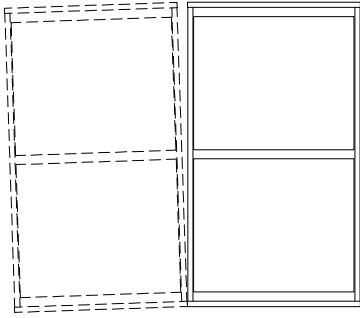

17

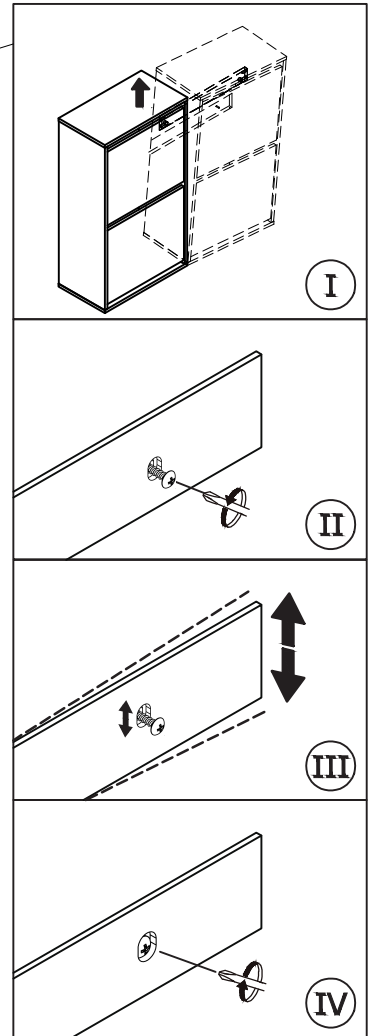
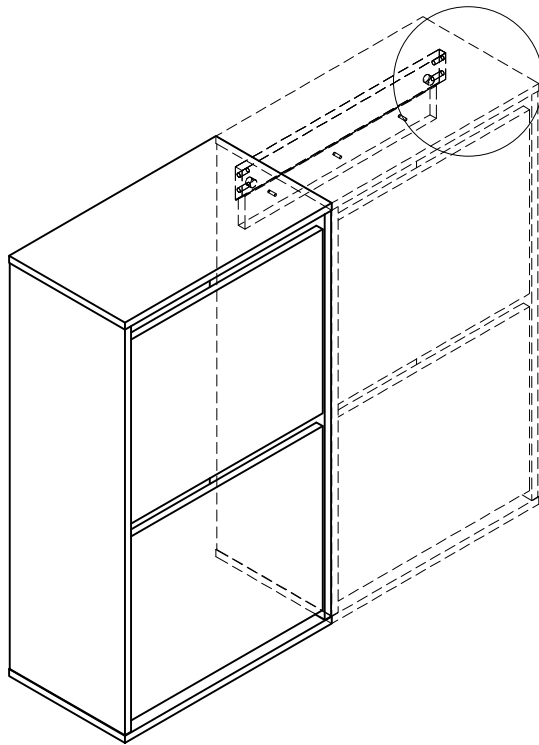
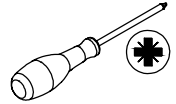

18

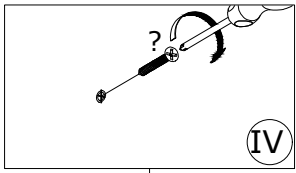
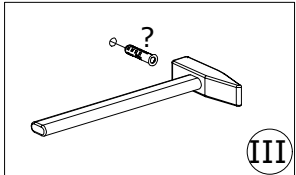
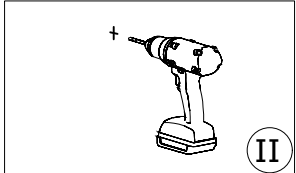
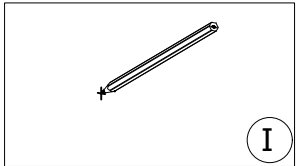
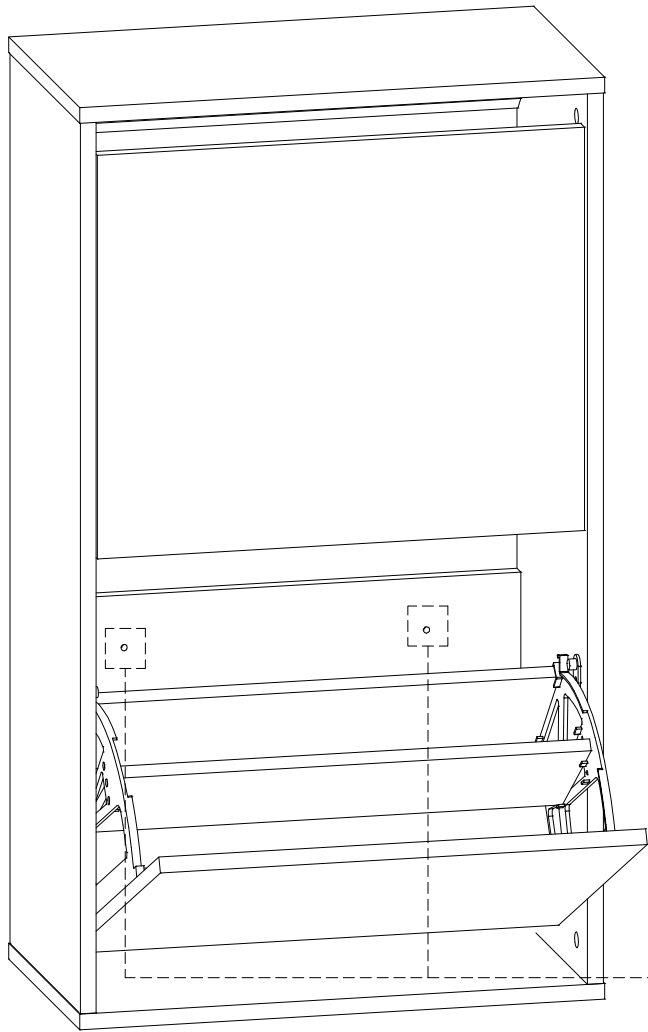
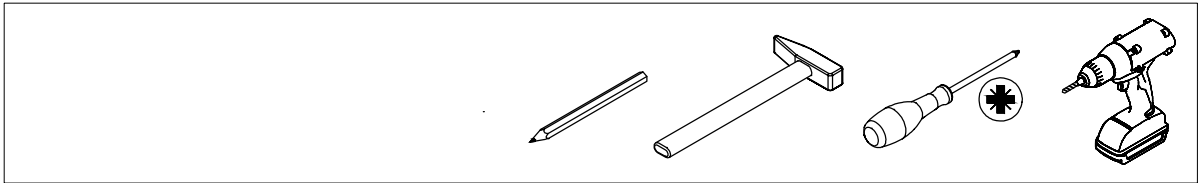

Note: For enhanced stability, you may install 2 additional screws at this position to secure the cabinet firmly to the wall.



19

